

This product utilizes R-454B refrigerant

VersaPro® & Hyper Heat Central Ducted

INSTALLATION & OWNER'S MANUAL

MODELS:

MVP-**-HP-MUAH-230A00-O

MVP-**-HP-C-230A00-O

CENTRAL-**-HP-C-230B00-O



Read this manual carefully before installation and keep it where the operator can easily find it for future reference.

Due to updates and constantly improving performance, the information and instructions within this manual are subject to change without notice.

Version Date: May 21, 2025

Please visit www.mrcool.com/documentation to ensure you have the latest version of this manual.



CONTENTS

1 SAFETY	2
2 ACCESSORIES	9
3 INDOOR UNIT INSTALLATION	10
3.1 Indoor Unit Parts	10
3.2 Safety Precautions	10
3.3 Installation Preparation & Precautions	11
3.4 Dimensions & Clearance Requirements	11
3.5 Installation Mounting Positions.....	17
3.6 Airflow Directions.....	17
3.7 Wire & Piping Connections	18
3.8 Horizontal Right & Downflow Configurations.....	18
3.9 Upflow & Horizontal Left Configurations	22
4 REFRIGERANT PIPING CONNECTION	23
4.1 Pipe Length & Elevation.....	23
4.2 Refrigerant Line Connection	24
5 ELECTRIC HEAT KIT INSTALLATION	28
6 CONFIRMATION OF INDOOR UNIT	30
6.1 Units with Electric Heat	30
6.2 Units without Electric Heat	30
6.3 Auxiliary Heater Electrical Data.....	30
6.4 Electrical Auxiliary Heating Wiring Diagrams	31
7 OUTDOOR UNIT INSTALLATION	35
7.1 Location Selection	35
7.2 Drain Fitting	36
7.3 Anchor Outdoor Unit	37
8 ELECTRICAL CONNECTIONS	39
8.1 Wiring Precautions	39
8.2 Wiring Overview	39
8.3 Outdoor Unit Wiring.....	40
8.4 Indoor Unit Wiring.....	41
8.5 Specific Wiring Methods	44
8.6 DIP Switch Definitions.....	47
9 SPECIFICATIONS	54
10 AIR EVACUATION	55
10.1 Air Evacuation Preparations & Precautions.....	55
10.2 Evacuation Instructions.....	55
11 ADDING REFRIGERANT	56
12 TEST RUN	57
12.1 Before Test Run	57
12.2 Test Run Instructions.....	57
12.3 24V Signal Chart.....	58
13 TROUBLESHOOTING	59
13.1 Error Display (Indoor Unit)	59
13.2 Information Inquiry.....	60
13.3 Error Display (Outdoor Unit).....	63
13.4 Outdoor Point Check Function	64

Safety Precautions

Read Before Using

Incorrect usage may cause serious damage or injury.

The symbols below are used throughout this manual to indicate instructions that should be followed closely or actions that should be avoided to prevent death, injury, and/or property damage.



Indicates a medium level of risk which, if not avoided, may result in death or serious injury.



Indicates a low degree of risk which, if not avoided, may result in minor or moderate injury.

NOTICE

Indicates important information but not danger.

WARNINGS FOR PRODUCT INSTALLATION

INSTALLATION MUST BE PERFORMED BY AN AUTHORIZED DEALER OR SPECIALIST. DEFECTIVE INSTALLATION CAN CAUSE WATER LEAKAGE, ELECTRICAL SHOCK, OR FIRE.

******ELECTRICAL WORK MUST BE COMPLETED BY A QUALIFIED ELECTRICAL TECHNICIAN******

 ***DO NOT*** install the unit in a location that may be exposed to combustible gas leaks. If combustible gas accumulates around the unit, it could cause fire.

 ***DO NOT*** turn on the power until the installation and all work has been completed.

 ***DO NOT*** install a unit equipped with an auxiliary electric heater within 3 ft (1 m) of any combustible materials.

1. Turn off the unit and disconnect the power before performing any installation or repairs. Failure to do so can cause electric shock.
2. Installation must be performed according to the installation instructions. Improper installation could cause water leakage, electrical shock, fire, and could void the warranty. Contact an authorized service technician for repair or maintenance of this unit. This appliance must be installed in accordance with national wiring regulations.
3. Only use the included accessories, parts, and specified parts for installation. Using non-standard parts can cause water leakage, electrical shock, fire, and/or failure of the unit.
4. Install the unit in a firm location that can support the unit's weight. If the location cannot support the unit's weight, or the installation is not done properly, the unit may drop and cause serious injury and damage.
5. Install the drainage piping according to the instructions in this manual. Improper drainage could cause water damage to your home and/or property.
6. When moving or relocating the air conditioner, consult experienced service technicians for disconnection and re-installation of the unit.
7. For detailed information of how to install the indoor and outdoor units to their respective supports, please refer to the indoor unit installation and outdoor unit installation sections of this manual.
8. For units with a wireless network function, the USB device access, replacement, and maintenance operations must be carried out by professional staff.
9. Refer to details further in this manual regarding installing the unit to its support.



WARNINGS FOR PRODUCT USE

- ⓘ ***DO NOT*** insert fingers, rods, or other objects into the air inlet or outlet. This could cause injury, since the fan may be rotating at high speeds.
 - ⓘ ***DO NOT*** use flammable sprays such as hair spray, lacquer or paint near the unit, as this could cause fire and/or an explosion.
 - ⓘ ***DO NOT*** operate the unit in places near or around combustible gases. Emitted gas may collect around the unit and cause an explosion.
 - ⓘ ***DO NOT*** allow children to play with the appliance. Children must be supervised around the unit at all times.
 - ⓘ ***DO NOT*** operate the unit in a room where it could be exposed to excessive amounts of water, such as a bathroom or laundry room. Exposure to excessive water amounts can cause the electrical components to short circuit.
 - ⓘ ***DO NOT*** expose your body directly to direct cool airflow from the unit for a prolonged period of time.
1. If the unit operates abnormally (emits strange noises or a burning smell), immediately turn off the unit and disconnect the power in order to avoid electric shock, fire, and/or injury. Call your local dealer, or MRCOOL® tech support at (270) 366-0457, for further assistance.
 2. If the air conditioner is used together with burners or other heating devices, thoroughly ventilate the room in order to avoid an oxygen deficiency.
 3. In certain functional environments (such as kitchens and server rooms etc.), the use of specially designed air-conditioning units is highly recommended.
 4. This appliance can be used by children (8 years and older) and persons with reduced physical, sensory or mental capabilities, or lack of experience and knowledge if they have been given instruction concerning the use of the appliance and understand the hazards involved.
 5. Improper installation, adjustment, alteration, service, or maintenance can cause property damage, personal injury or loss of life. Installation and service must be performed by a licensed professional HVAC installer, service agency, or the gas supplier.



ELECTRICAL WARNINGS

******ELECTRICAL WORK MUST BE COMPLETED BY A QUALIFIED ELECTRICAL TECHNICIAN******

- ⓘ ***DO NOT*** share the power supply with other appliances. The unit must be installed on a dedicated electrical circuit. An improper or insufficient power supply could cause fire and/or electrical shock.
1. The product must be properly grounded during installation or electrical shock could occur.
 2. Appropriate wiring standards, regulations, and the installation manual must be followed for all electrical work.
 3. If connecting power to fixed wiring, an all-pole disconnection device must be incorporated in the fixed wiring in accordance with the wiring rules and must meet the following requirements: at least 3 mm of clearances in all poles, a leakage current that may exceed 10 mA, and a residual current device (RCD) having a rated residual operating current not exceeding 30 mA.
 4. For all electrical work, fuse the specified cables. Connect cables tightly and clamp them securely to prevent external forces from damaging the terminal. Improper electrical connections could overheat, causing fire and/or electrical shock.
 5. All electrical connections must be made according to the Electrical Connection Diagram located on the panels of the indoor and outdoor units.
 6. All wiring must be properly arranged to ensure that the control board cover can close properly. If the control board cover is not properly closed, it can lead to corrosion and cause the connection points on the terminal to heat up, catch fire, or cause electrical shock.
 7. Only use the specified wire. If the wire is damaged, it must be replaced by the manufacturer, its service agent, or similarly qualified person in order to avoid a hazard.
 8. Disconnection must be incorporated in the fixed wiring in accordance with the NEC, CEC, or local codes.



WARNINGS FOR CLEANING & MAINTENANCE

⚠ **DO NOT** clean the unit with excessive amounts of water.

⚠ **DO NOT** clean unit with combustibile cleaning agents, as these could cause deformation and/or fire.

1. Turn off the device and disconnect the power before cleaning. Failure to do this could result in electrical shock.

TAKE NOTE OF FUSE SPECIFICATIONS

- The unit's circuit board (PCB) is designed with a fuse to provide over-current protection. This fuse must be replaced with an identical component if the existing fuse is blown.
- The specifications of the fuse are printed on the circuit board, examples of such are T3.15AL/250VAC, T5AL/250VAC, T3.15A/250VAC, T5A/250VAC, T20A/250VAC, T30A/250VAC, etc.
- **NOTE:** Only blast-proof ceramic fuses can be used.

! CAUTION

⚠ **DO NOT** allow the air conditioner to operate for extended periods of time with the doors or windows open, or in very high humidity.

⚠ **DO NOT** operate the air conditioner with wet hands, as this could cause electric shock.

⚠ **DO NOT** use device for any other purpose than its intended use.

⚠ **DO NOT** climb onto or place objects on top of the outdoor unit.

1. Make sure that water condensation can drain smoothly and unhindered from the unit.
2. Turn off the unit and disconnect the power if the unit will not be used for an extended period of time.
3. As with any mechanical equipment, contact with sharp metal edges can result in personal injury. Ensure care is taken when handling the unit and any of its accessories by wearing gloves and protective clothing.

NOTE ON FLUORINATED GASES (NOT APPLICABLE FOR R-290 UNITS):

1. This unit contains fluorinated greenhouse gases.
2. For specific information on the type of gas and the amount, please refer to the relevant label on the unit itself.
3. Service, maintenance, and repair of this unit must be performed by a certified technician.
4. Product un-installation and recycling must be performed by a certified technician.
5. When checking the unit for leaks, maintain proper record-keeping of all checks.

NOTE ON STATIC PRESSURE:

The allowed static pressure range of the air conditioner on site 0.00-0.80 in H₂O (0-200 Pa).
The data below represents the static pressures at the full required airflow used for AHRI testing.

Model	18-24K	30-36K	48-60K
Pressure	0.5 in H ₂ O (125 Pa)	0.5 in H ₂ O (125 Pa)	0.5 in H ₂ O (125 Pa)

Units: Inch of Water Column (Pascals)

NOTE: The maximum functional total external static pressure cannot exceed 0.80 in WC (200 Pa). The airflow reduces significantly with pressures above and beyond 0.80 in WC (200 Pa). The system design should allow for the increased resistance of filters as they become dirty.



FLAMMABLE REFRIGERANT WARNINGS

1. The installation of pipe-work should be kept to a minimum and should be protected from physical damage.
2. Refrigerant pipes should comply with national gas regulations.
3. All mechanical connections and ventilation openings should be kept clear of obstruction.
4. Utilize proper disposal processes based on national regulations.
5. Any person involved with working on or breaking into a refrigerant circuit should hold a current valid certificate from an industry-accredited assessment authority, which authorizes their competence to handle refrigerants safely in accordance with an industry recognized assessment specification.
6. Maintenance and repair requiring the assistance of other skilled personnel shall be carried out under the supervision of the person competent in the use of flammable refrigerants.
7. Do not use any means to accelerate the defrosting process or to clean, other than those recommended by the manufacturer.
8. The appliance shall be stored in a room without continuously operating ignition sources (for example: open flames, an operating gas appliance, or an operating electric heater).
9. Do not allow foreign matter (oil, water, etc.) to enter the piping, and securely seal the opening by pinching, taping, etc.
10. Do not pierce or burn.
11. Refrigerants may not contain an odor.
12. Working procedures that affect safety should only be carried out by competent persons.
13. The unit should be stored in a well-ventilated area where the room size corresponds to the room area as specific for operation, and should be stored so as to prevent potential mechanical damage from occurring.
14. Joints should be tested with detection equipment with a capability of 5 g/year of refrigerant or better, with the equipment in standstill and under operation or under a pressure of at least these standstill or operation conditions after installation. Detachable joints should NOT be used in the indoor side of the unit (brazed, welded joint could be used).
15. A leak detection system is installed. The unit must be powered except for service. For units with a refrigerant sensor, the indoor unit will display an error code and emit a buzzing sound, the compressor of the outdoor unit will immediately stop, and the indoor fan will start running. The service life of the refrigerant sensor is 15 years. When the refrigerant sensor malfunctions, the indoor unit will display the error code "FHCC". The refrigerant sensor cannot be repaired and can only be replaced by the manufacturer. It should only be replaced with the sensor specified by the manufacturer.
16. Prior to beginning work on systems containing flammable refrigerants, safety checks are necessary to ensure that the risk of ignition is minimized. For repairs to the refrigerating system, the following precautions shall be complied with prior to conducting work on the system.
17. Work should be undertaken under a controlled procedure so as to minimize the risk of a flammable gas or vapor being present while the work is being performed.
18. All maintenance staff and others working in the local area should be instructed on the nature of work being carried out. Avoid work in confined spaces.
19. The area should be checked with an appropriate refrigerant detector prior to and during work, to ensure the technician is aware of potentially flammable atmospheres. Ensure that the leak detection equipment being used is suitable for use with flammable refrigerants, i.e. no sparking, adequately sealed, or intrinsically safe.
20. If any hot work is to be conducted on the refrigeration equipment or any associated parts, appropriate fire extinguishing equipment should be on site and readily available. Have a dry power or CO2 fire extinguisher adjacent to the charging area.
21. No person carrying out work in relation to a refrigerating system which involves exposing any pipe work should use any sources of ignition in such a manner that it may lead to the risk of fire or explosion. All possible ignition sources, including cigarette smoking, should be kept sufficiently far away from the site of installation, repairing, removing, and disposal, during which refrigerant can possibly be released to the surrounding space. Prior to work taking place, the area around the equipment is to be surveyed to make sure that there are no flammable hazards or ignition risks. "No Smoking" signs should be displayed.
22. Ensure that the area is in the open or that it is adequately ventilated before breaking into the system or conducting any hot work. A degree of ventilation shall continue during the period that the work is carried out. The ventilation should safely disperse any released refrigerant and preferably expel it externally into the atmosphere.



FLAMMABLE REFRIGERANT WARNINGS

23. Where electrical components are being changed, they shall be fit for the purpose and to the correct specification. At all times the manufacturer's maintenance and service guidelines shall be followed. If in doubt, consult the manufacturer's technical department for assistance. The following checks should be applied to installations using flammable refrigerants:
- the actual refrigerant charge is in accordance with the room size within which the refrigerant containing parts are installed;
 - the ventilation machinery and outlets are operating adequately and are not obstructed;
 - if an indirect refrigerating circuit is being used, the secondary circuits should be checked for the presence of refrigerant;
 - marking to the equipment continues to be visible and legible, marking and signs that are illegible should be corrected;
 - refrigeration pipe or components are installed in a position where they are unlikely to be exposed to any substance which may corrode refrigerant containing components, unless the components are constructed of materials which are inherently resistant to being corroded or are suitably protected against being so corroded.
24. Repair and maintenance to electrical components shall include initial safety checks and component inspection procedures. If a fault exists that could compromise safety, then no electrical supply shall be connected to the circuit until it is satisfactorily dealt with. If the fault cannot be corrected immediately but it is necessary to continue operation, an adequate temporary solution should be used.
25. Initial safety checks should include:
- that capacitors are discharged: this should be done in a safe manner to avoid the possibility of sparking;
 - that there are no live electrical components and wiring are exposed while charging, recovering, or purging the system;
 - that there is continuity of earth bonding.
26. Sealed electrical components should be replaced if damaged.
27. Intrinsically safe components should be replaced if damaged.
28. Check that wiring will not be subject to wear, corrosion, excessive pressure, vibration, sharp edges, or any other adverse environmental effects. The check shall also take into account the effects of aging or continual vibration from sources such as compressors or fans.
29. Under no circumstances should potential sources of ignition be used in the search for or detection of refrigerant leaks. A halide torch (or any other detector using a naked flame) should not be used. The following leak detection methods are deemed acceptable for refrigerant systems. Electronic leak detectors may be used to detect refrigerant leaks but, in the case of flammable refrigerants, the sensitivity may not be adequate, or may need re-calibration. (Detection equipment shall be calibrated in a refrigerant-free area.) Ensure that the detector is not a potential source of ignition and is suitable for the refrigerant used. Leak detection equipment shall be set at a percentage of the LFL of the refrigerant and should be calibrated to the refrigerant employed, and the appropriate percentage of gas (25% minimum) is confirmed. Leak detection fluids are also suitable for use with most refrigerants but the use of detergents containing chlorine may react with the refrigerant and corrode the copper work. Examples of leak detection fluids are the bubble method, fluorescent method agents, etc. If a leak is suspected, all naked flames should be removed/extinguished. If a leakage of refrigerant is found which requires brazing, all of the refrigerant should be recovered from the system, or isolated (by means of shut-off valves) in a part of the system remote from the leak. See the following instructions of removal of refrigerant.
30. When breaking into the refrigerant circuit to make repairs, or for any other purpose, conventional procedures should be used. However, for flammable refrigerants, it is even more vital to follow best practice. The following procedure should be adhered to:
- safely remove refrigerant following local and national regulations;
 - evacuate;
 - purge the circuit with inert gas;
 - evacuate;
 - continuously flush or purge with inert gas when using flame to open circuit;
 - open the circuit



FLAMMABLE REFRIGERANT WARNINGS

31. The refrigerant charge should be recovered into the correct recovery cylinders if venting is not allowed by local and national codes. For units containing flammable refrigerants, the system should be purged with oxygen-free nitrogen to render the appliance safe for flammable refrigerants. This process might need to be repeated several times. Compressed air or oxygen shall not be used for purging refrigerant systems. For appliances containing flammable refrigerants, refrigerant purging should be achieved by breaking the vacuum in the system with oxygen-free nitrogen and continuing to fill the working pressure is achieved, then venting to atmosphere, and finally pulling down to a vacuum. This process should be repeated until no refrigerant is within the system. When the final oxygen-free nitrogen charge is used, the system should be vented down to atmospheric pressure to enable work to take place. The outlet for the vacuum pump should not be close to any potential ignition sources, and ventilation should be available.
32. In addition to conventional charging procedures, the following requirements should be followed:
 - Work should be undertaken with appropriate tools only (in case of uncertainty, please consult the manufacturer of the tools for use with flammable refrigerants).
 - Ensure that contamination of different refrigerants does not occur when using charging equipment. Hoses or lines shall be as shot as possible to minimize the amount of refrigerant contained in them.
 - Cylinders should be kept upright.
 - Ensure that the refrigeration system is grounded prior to charging the system with refrigerant.
 - Label the system when charging is complete (if not already).
 - Extreme care should be taken not to overfill the refrigeration system.
 - Prior to recharging the system, it should be pressure tested with oxygen-free nitrogen (OFN). The system should be leak-tested on completion of charging but prior to commissioning. A follow-up leak test shall be carried out prior to leaving the site.
33. Before carrying out this procedure, it is essential that the technician is completely familiar with the equipment and all its detail. It is good recommended practice that all refrigerants are recovered safely. Prior to the task being carried out, an oil and refrigerant sample should be taken in case analysis is required prior to re-use of recovered refrigerant. It is essential that electrical power is available before the task is commenced.
 - a. Become familiar with the equipment and its operation.
 - b. Isolate the system electrically.
 - c. Before attempting the procedure ensure that:
 - mechanical handling equipment is available, if required, for handling refrigerant cylinders;
 - all personal protective equipment is available and being used correctly;
 - the recovery process is supervised at all times by a competent person;
 - recovery equipment and cylinders conform to the appropriate standards
 - d. Pump down refrigerant system, if possible.
 - e. If a vacuum is not possible, make a manifold so that refrigerant can be removed from various parts of the system.
 - f. Make sure that the cylinder is situated on the scales before recovery takes place.
 - g. Start the recovery machine and operate in accordance with instructions.
 - h. Do not overfill cylinders (no more than 80% volume liquid charge).
 - i. Do not exceed the maximum working pressure of the cylinder, even temporarily.
 - j. When the cylinders have been filled correctly and the process completed, make sure that the cylinders and equipment are removed from the site promptly and all isolation valves on the equipment are closed off.
 - k. Recovered refrigerant should not be charged into another refrigeration system unless it has been cleaned and checked.
34. Equipment shall be labeled stating that it has been decommissioned and emptied of refrigerant. The label should be dated and signed. For appliances containing flammable refrigerants, ensure that there are labels on the equipment stating the equipment contains flammable refrigerant.



FLAMMABLE REFRIGERANT WARNINGS

35. When removing refrigerant from a system, either for servicing or decommissioning, it is good recommended practice that all refrigerants are removed safely. When transferring refrigerant into cylinders, ensure that only appropriate refrigerant recovery cylinders are employed. Ensure that the correct number of cylinders for holding the total system charge is available. All cylinders to be used should be designated for the recovered refrigerant and labeled for that refrigerant (i.e. special cylinders for the recovery of refrigerant). Cylinders shall be complete with pressure-relief valve and associated shut-off valves in good working order. Empty recovery cylinders are evacuated and, if possible, cooled before recovery occurs. The recovery equipment should be in good working order with a set of instructions concerning the equipment that is at hand and should be suitable for the recovery of the flammable refrigerant. If in doubt, the manufacturer should be consulted. In addition, a set of calibrated weighing scales should be available and in good working order. Hoses should be complete with leak-free disconnect couplings and in good condition. The recovered refrigerant should be processed according to local legislation in the correct recovery cylinder, and the relevant waste transfer note arranged. Do not mix refrigerants in recovery units and especially not in cylinders. If compressors or compressor oils are to be removed, ensure that they have been evacuated to an acceptable level to make certain that flammable refrigerant does not remain within the lubricant. The compressor body should not be heated by an open flame or other ignition sources to accelerate this process. When oil is drained from a system, it should be carried out safely.
36. An unventilated area where the appliance using flammable refrigerants is installed should be constructed so that should any refrigerant leak, it will not stagnate so as to create a fire or explosion hazard. If appliances connected via an air duct system to one or more rooms below the ventilation requirements, that room should never contain potential ignition sources. A flame-producing device may be installed in the space if the device is provided with an effective flame arrest. Auxiliary devices which may be a potential ignition source should not be installed in the duct work. Examples of such are hot surfaces with a temperature exceeding 1292°F (700°C) and electric switching devices. Only auxiliary devices (such as a certified heater kit) approved by the manufacturer or declared suitable with the refrigerant should be installed in connecting ductwork. False or drop ceilings may be used as a return air plenum if a refrigerant detection system is provided in the appliance and any external connections are also provided with a sensor immediately below the return air plenum duct joint. Refrigerant sensors for refrigerant detection systems should only be replaced with sensors specified by the manufacturer. A leak detection system is installed. The unit must be powered except for service.
37. Transport of equipment containing flammable refrigerants should comply with transportation regulations.
38. Marking of equipment using signs should comply with local regulations.
39. Disposal of equipment using flammable refrigerants should comply with national regulations.
40. Storage of equipment/appliances should be in accordance with the manufacturer's instructions.
41. Storage of packed (unsold) equipment should be constructed so that mechanical damage to the equipment inside the package will not cause a leak of the refrigerant charge. The maximum number of pieces of equipment permitted to be stored together will be determined by local regulations.

Symbols Displayed on Indoor & Outdoor Unit











	WARNING	This symbol shows that this appliance uses a flammable refrigerant. If the refrigerant is leaked and exposed to an external ignition source, there is a risk of fire.
	CAUTION	This symbol shows that the operation manual should be read carefully.
	CAUTION	This symbol shows that a service personnel should be handling this equipment with reference to the installation manual.
	CAUTION	
	CAUTION	This symbol shows that information is available such as the operating manual or installation manual.

2 ACCESSORIES



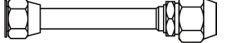



2-Accessories

The listing below shows the accessories and parts (these may vary depending on purchase & options). Use all of the installation parts and accessories to install the system. Improper installation may result in water leakage, electrical shock, fire, and/or equipment failure.

Indoor Unit:

PART	LOOKS LIKE	QUANTITY
Owner's & Installation Manual		1
MRCOOL Smart Thermostat		1 (Wifi required for setup)
MRCOOL Smart Thermostat Manual		1
Cable Ties		6
Insulation Sleeve		2
Sound-Deadening Pads		4
Braze to Flare Adapter		2
5/8flare → 3/4flare adapter (For 18K Regular Heat Series)		1
Screwdriver		1
24V Thermostat Adapter (Black)		1
24V Transformer Adapter (For 115V)		1

Outdoor Unit:

PART	LOOKS LIKE	QUANTITY
Braze to Flare Adapter		2
Allen Key		1
Drain Joint		1
Seal Ring (Not included for 48K & 60K outdoor units)		1
Rubber Installation Pads		4
Flare Nut (2 on unit / 2 in packaging)		4 (2) 2-3/8" (2) 2-3/4"

NOTE: The filter is not included with the unit and must be purchased separately.

3 INDOOR UNIT INSTALLATION

3.1 Indoor Unit Parts

Coil compartment
(Access panel Removed)

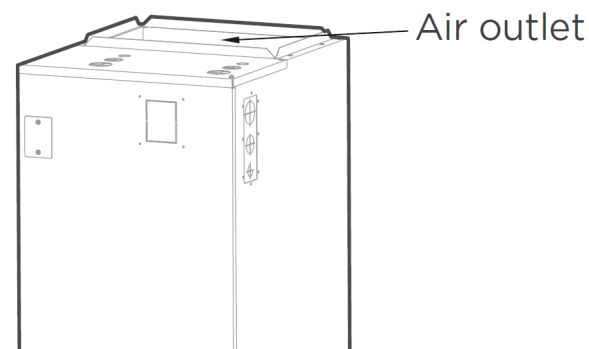
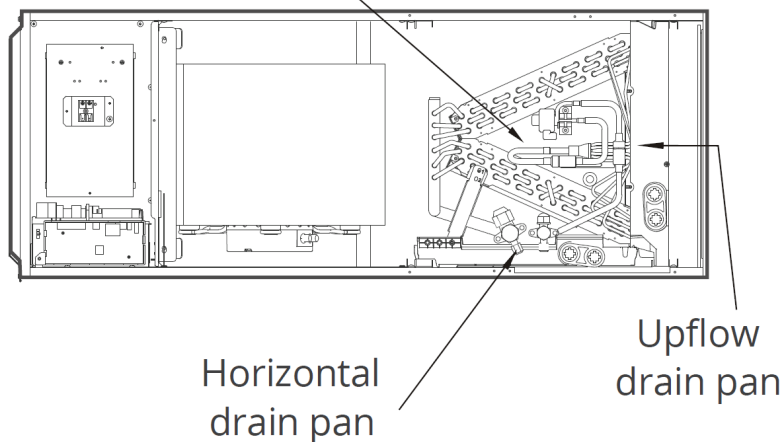

3.2 Safety Precautions

! WARNING

⚠ **DO NOT** install the indoor unit in any of the following locations:

- Areas with excessive moisture which can corrode the equipment, electrical components, and cause electrical shorts.
- Areas where oil drilling or fracking is being performed.
- Coastal areas with high salt content in the air.
- Areas with strong electromagnetic waves.
- Areas where flammable materials or gas are stored.
- Areas where the air inlet and outlet may be obstructed.
- Areas where there may be detergent or other corrosive gases in the air, such as bathrooms or laundry rooms.
- Areas near flammable materials and vapors, such as gasoline.

! CAUTION

- Install the indoor and outdoor units, cables, and wires at least 3.2 ft (1 m) away from televisions or radios to prevent static or image distortion. Depending on the appliances, a 3.2ft (1m) distance may not be sufficient.
- The indoor unit must be electrically grounded per national and local electrical codes.

! WARNING

- Be sure to apply sealant around any places where wires, refrigerant piping, and condensate piping enter the air handler cabinet.
- Use duct tape and/or Permagum to seal any space around the holes where condensate piping exits the cabinet. Warm air must not be allowed to enter through any gaps or holes in the cabinet.
- Remove all accessories and packing from the air outlet before installation.

! WARNING

- There must be an airtight seal between the bottom of the air handler and the return air plenum. In order to achieve this, use fiberglass sealing strips, foil duct tape, caulking, or an equivalent sealing method to ensure a tight seal.
- Return air must not be drawn from a room where the air handler or any gas-fueled appliance (ex: water heater), or carbon monoxide-producing device (ex: wood fireplace) is installed.

3 INDOOR UNIT INSTALLATION

3.3 Installation Preparation & Precautions

The indoor unit should be installed in a location that meets the following requirements:

- ✓ On a structure that can support its weight. If the structure is too weak, the unit may fall and cause personal injury, unit and property damage, or death.
- ✓ Enough room for the installation and maintenance to be performed.
- ✓ Heating elements are at least 18 inches (46 cm) above the floor for a garage installation. Failure to follow these instructions can result in death, explosion, or fire.
- ✓ Enough room for the connecting pipe and drainpipe.
- ✓ The structure that the equipment is suspended from must support the weight of the indoor unit.

3.4 Dimensions & Clearance Requirements

Indoor Unit Clearance Requirements

The distance between the mounted indoor unit should meet the specifications illustrated in the following diagrams.

Horizontal Installations

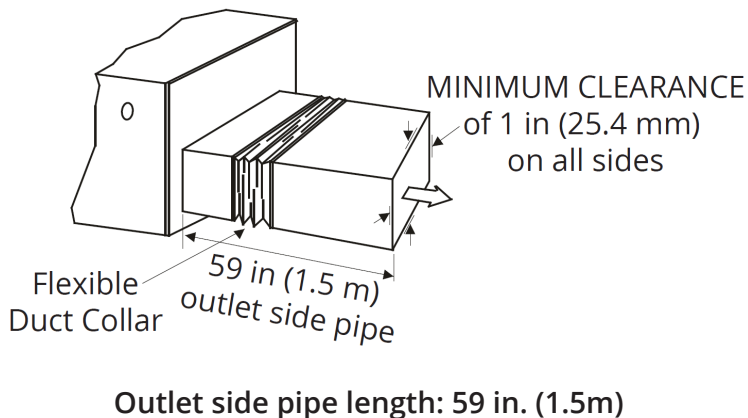

Vertical Installations



Mounting instructions: When installed vertically (upflow or downflow), the lower end of the air outlet needs to be connected to the L-shaped metal air duct and fastened by screws. If return air is to be ducted, install duct flush with floor. Set unit on floor over opening. All return air must pass through coil.

3 INDOOR UNIT INSTALLATION

Dimensions

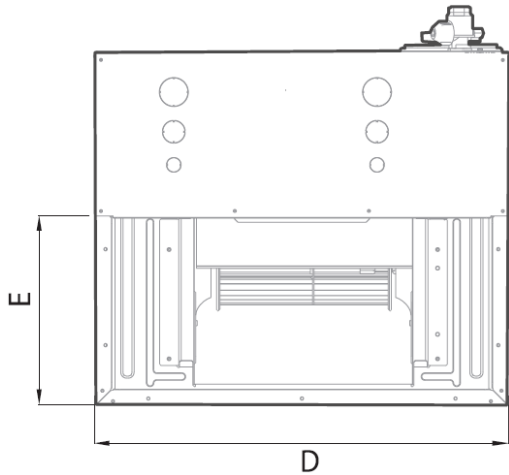
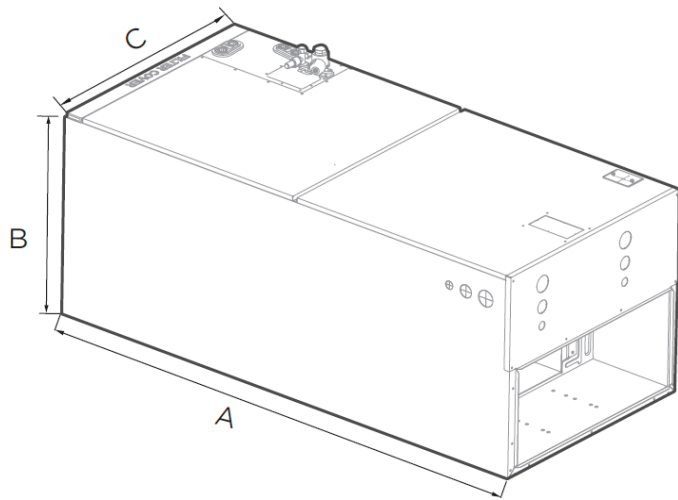

Dimensions	Model Capacity (BTU/H)		
	18K/24K	30K/36K	48K/60K
Length of A	45 in (1143 mm)	49 in (1245 mm)	53 in (1346 mm)
Length of B	21 in (533 mm)	21 in (533 mm)	21 in (533 mm)
Length of C	17.5 in (445 mm)	21.02 in (534 mm)	24.5 in (622 mm)
Length of D	15.75 in (400 mm)	19.3 in (490 mm)	22.8 in (580 mm)
Length of E	10.25 in (260 mm)	10.25 in (260 mm)	10.25 in (260 mm)

Filter Dimensions

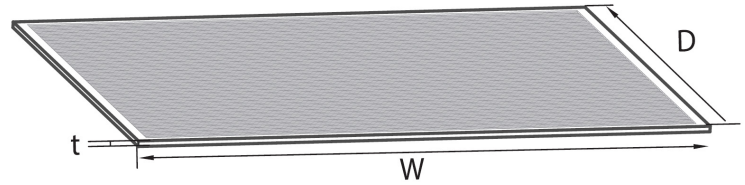

Filter must meet the requirements of UL900.

Model Capacity (BTU/H)	Width (W)	Depth (D)	Thickness (t)
18K/24K	16 in (406.4 mm)	20 in (508 mm)	1 in (25.4 mm)
30K/36K	19 in (495.3 mm)	20 in (508 mm)	1 in (25.4 mm)
48K/60K	23 in (584.2 mm)	20 in (508 mm)	1 in (25.4 mm)

NOTE: The filter is not included with the unit and must be purchased separately.

Installation Position Requirements

Top View

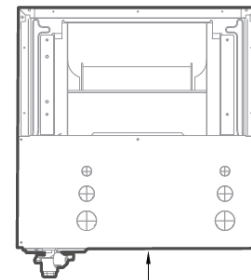

24inch(min)



Vertical installations

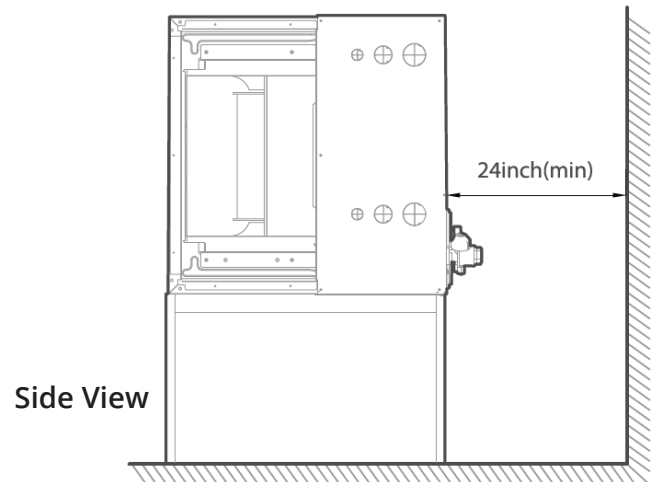

Side View

Horizontal installations

Note on Ductwork & Connections

- Air supply and return can be handled in one of several ways depending on which is best suited for the type of installation. Please see the dimensions on the previous page to determine duct inlet and outlet connection sizes to match the air handler. The vast majority of problems encountered with combination cooling systems can be linked to improperly designed or installed ductwork. For this reason, it is highly important that the duct system be properly designed and installed.
- The use of flexible duct collars will minimize the transmission of vibration and noise into the conditioned space. In an installation where the return air duct is short, or where sound is likely to be a problem, a sound absorbing liner should be used inside the duct.
- Insulation of the ductwork is a requirement anywhere it runs through an uncooled space during the cooling season.
- The use of a vapor barrier is recommended to prevent absorption of moisture from the surrounding air into the insulation.
- The supply air duct should utilize a properly sized transition in order to match the unit opening.
- All ducts should be suspended using flexible hangers and never fastened directly to the structure. This unit is not designed for non-ducted (free-blow) applications.
- Ductwork should be fabricated and installed in accordance with local and/or national codes.

! CAUTION

- A field-fabricated secondary drain pan (not included), with a drain pipe to the outside of the building is required in all installations over a finished living space or in any area that may be damaged by overflow from the main drain pan. **NOTE: A secondary drain pan is required for horizontal installations.**
- This unit is not designed for non-ducted (free-blow) applications. Electric heat kit elements and/or blower is easily accessible without ductwork and creates a safety hazard that could result in electric shock and/or personal injury.

Room Size Restriction

The units are connected via an air duct to one or more rooms, the bottom of the air outlet of the air duct in the room should be at a height ≥ 7.3 ft (2.2m) from the floor. In UL/CSA 60335-2-40, the R454B refrigerant belongs to mildly flammable refrigerants, which will limit the room area of the system service. Similarly, the total amount of refrigerant in the system should be less than or equal to the maximum allowable refrigerant charge, which depends on the room area serviced by the system.

SECTION TERMINOLOGY

Mc: the actual refrigerant charge in the system

A: the actual room area where the appliance is installed

Amin: the required minimum room area

Mmax: the allowable maximum refrigerant charge in a room

Qmin: the minimum circulation airflow

Anvmin: the minimum opening area for connected rooms

T Amin: the total area of the conditioned space (for appliances serving one or more rooms with an air duct system)

TA: The total area of the conditioned space connected by air ducts.

Refrigerant Charge and Room Area Limitations

For the purpose of determination of room area (A) when used to calculate the maximum allowable refrigerant charge (mmax) in an unventilated space, the following shall apply.

The room area (A) shall be defined as the room area enclosed by the projection to the floor of the walls, partitions and doors of the space in which the appliance is installed. Spaces connected by only drop ceilings, ductwork, or similar connections shall not be considered a single space.

For units mounted higher than 6 ft (1.8m), spaces divided by partition walls which are no higher than 5.3ft/1.6m shall be considered a single space.

3 INDOOR UNIT INSTALLATION

For fixed appliances, rooms on the same floor and connected by an open passageway between the spaces can be considered a single room when determining compliance to Amin, if the passageway complies with all of the following:

- it is a permanent opening
- it extends to the floor
- it is intended for people to walk through

For fixed appliances, the areas of the adjacent rooms, on the same floor, connected by a permanent opening in the walls and/or doors between occupied spaces, including gaps between the wall and the floor, can be considered a single room when determining compliance to Amin, provided all of the following are met:

- the space shall have appropriate openings
- the minimum opening area for natural ventilation Anvmin shall not be less than the following:

Height of Outlet/m	A/m ²	Mc/kg	Mmax/kg	Anvmin/m ²
2.2	5	5.0	2.685	0.045
2.2	6	5.0	2.941	0.042
2.2	7	5.0	3.177	0.038
2.2	8	5.0	3.396	0.035
2.2	9	5.0	3.602	0.031
2.2	10	5.0	3.797	0.028
2.2	11	5.0	3.983	0.024
2.2	12	5.0	4.160	0.020
2.2	13	5.0	4.330	0.016
2.2	14	5.0	4.493	0.013
2.2	15	5.0	4.651	0.009
2.2	16	5.0	4.803	0.005
2.2	17	5.0	4.951	0.001

NOTE

Take the Mc=5.0kg as an example. For appliances serving one or more rooms with an air duct system, the room area calculation should be determined based on the total area of the conditioned space (TA) connected by ducts taking into consideration that the circulating airflow distributed to all the rooms by the appliance integral indoor fan will mix and dilute the leaking refrigerant before entering any room.

3 INDOOR UNIT INSTALLATION

Opening Conditions for Connected Rooms

When the openings for connected rooms are required, the following conditions should be applied:

- the area of any openings above 11.81in (300mm) from the floor should not be considered in determining compliance with Anvmin.
- at least 50% of the required opening area Anvmin should be below 7.87in (200mm) from the floor.
- the bottom of the lowest openings should not be higher than the point of release when the unit is installed and not more than 3.94in (100mm) from the floor.
- openings are permanent openings which cannot be closed (for openings extending to the floor, the height should not be less than .79in (20mm) above the surface of the floor covering)
- A second higher opening should be provided. The total size of the second opening should not be less than 50% of the minimum opening area for Anvmin and should be at least 4.9ft (1.5m) above the floor. (NOTE: The requirement for the second opening can be met by drop ceilings, ventilation ducts, or similar arrangements that provide an airflow path between the connected rooms.)
- The room into which refrigerant can leak, plus the connected adjacent room(s) should have a total area of no less than Tamin.
- The room in which the unit is installed should not be less than 20% Tamin.

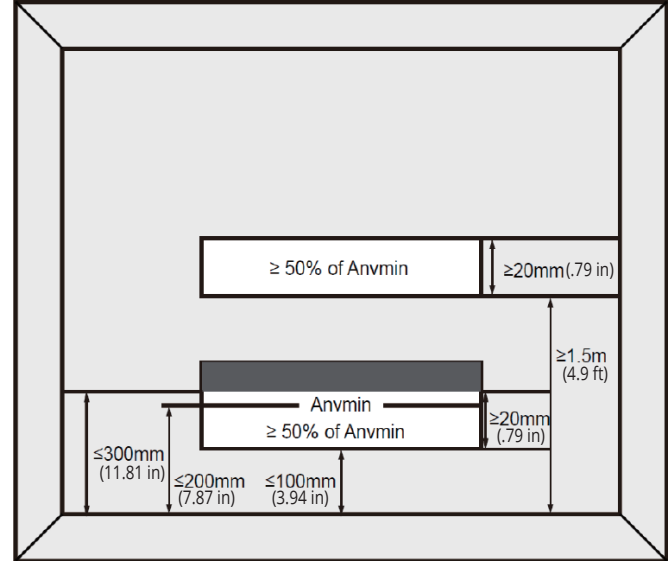

454B Refrigerant Charge Amount & Minimum Room Area

The unit matches the following table. The indoor and outdoor units are designed to be used together. Refer to the unit you purchased. The minimum room area of operating or storage should be as specified in the following table:

Product Series	Model	Indoor Unit	Outdoor Unit
24V Pre-Charge Refrigerant	18K (208/230V)	MVP-18-HP-MUAH-230A00-O	MVP-18-HP-C-230A00-O
	24K (208/230V)	MVP-24-HP-MUAH-230A00-O	MVP-24-HP-C-230A00-O CENTRAL-24-HP-C-230B00-O
	30K (208/230V)	MVP-30-HP-MUAH-230A00-O	MVP-30-HP-C-230A00-O CENTRAL-24-HP-C-230B00-O
	36K (208/230V)	MVP-36-HP-MUAH-230A00-O	MVP-36-HP-C-230A00-O CENTRAL-24-HP-C-230B00-O
	48K (208/230V)	MVP-48-HP-MUAH-230A00-O	MVP-48-HP-C-230A00-O CENTRAL-24-HP-C-230B00-O
	60K (208/230V)	MVP-60-HP-MUAH-230A00-O	MVP-60-HP-C-230A00-O CENTRAL-24-HP-C-230B00-O

3 INDOOR UNIT INSTALLATION

Mc or MREL [oz/kg]	TAmin [ft ² /m ²]	Mc or MREL [oz/kg]	TAmin [ft ² /m ²]	Mc or MREL [oz/kg]	TAmin [ft ² /m ²]	Mc or MREL [oz/kg]	TAmin [ft ² /m ²]
<=62.7/1.776	12/1.1	134/3.8	126/11.67	211.6/6.0	198/18.43	289.2/8.2	271/25.18
63.5/1.8	60/5.53	141.1/4	132/12.29	218.7/6.2	205/19.04	296.3/8.4	278/25.8
70.5/2	66/6.14	148.1/4.2	139/12.9	225.8/6.4	212/19.66	303.4/8.6	284/26.41
77.6/2.2	73/6.76	155.2/4.4	145/13.51	232.8/6.6	218/20.27	310.4/8.8	291/27.63
84.6/2.4	79/7.37	162.2/4.6	152/14.3	239.9/6.8	225/20.88	317.5/9.0	298/27.64
91.7/2.6	86/7.99	169.3/4.8	159/14.74	246.9/7.0	231/21.5	324.5/9.2	304/28.26
98.8/2.8	93/8.6	176.4/5	165/15.36	254/7.2	238/22.11	331.6/9.4	311/28.87
105.8/3	99/9.21	183.4/5.2	172/15.97	261/7.4	245/22.73	338.6/9.6	317/29.48
112.9/3.2	106/9.83	190.5/5.4	179/16.58	268.1/7.6	251/23.34	345.7/9.8	324/30.10
119.9/3.4	112/10.44	197.5/5.6	185/17.2	275.1/7.8	258/23.96	352.7/10.0	331/30.71
127/3.6	119/11.06	204.6/5.8	192/17.81	282.2/8.0	264/24.57		
Area Formula	<p>TAmin is the required minimum room area in ft²/m².</p> <p>Mc is the actual refrigerant charge in the system in oz/kg.</p> <p>MREL is the height of the bottom of the appliance relative to the floor of the room after installation.</p> <p>WARNING: The minimum room area or minimum room area of conditioned space is based on releasable charge and total system refrigerant charge.</p>						

When the unit detects a refrigerant leak, the minimum airflow of the indoor unit is as follows:

Model	18K	24K	30K	36K	48K	60K
Nominal Air Volume	400CFM (680m ³ /h)	400CFM (680m ³ /h)	447CFM (760m ³ /h)	541CFM (920m ³ /h)	706CFM (1200m ³ /h)	824CFM (1400m ³ /h)

3 INDOOR UNIT INSTALLATION

3.5 Installation Mounting Positions

The unit can be installed in a Vertical (downflow or upflow) or a Horizontal (right or left) configuration.

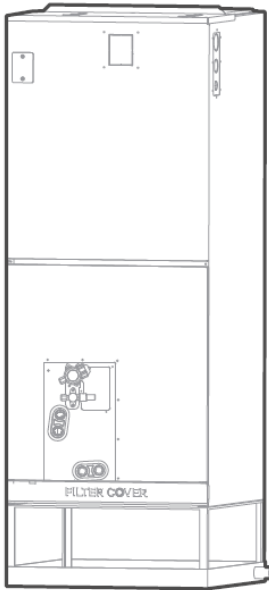

Vertical up

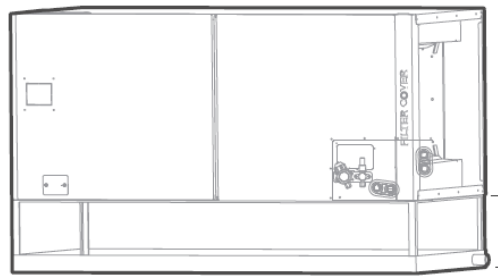

Horizontal

At least
5in(127mm)

NOTE

- Vertical Up and Horizontal Left installation does not require a change to the direction of the evaporator.
- For Horizontal installation, a secondary drain pan (not supplied) must be installed.

3.6 Airflow Directions

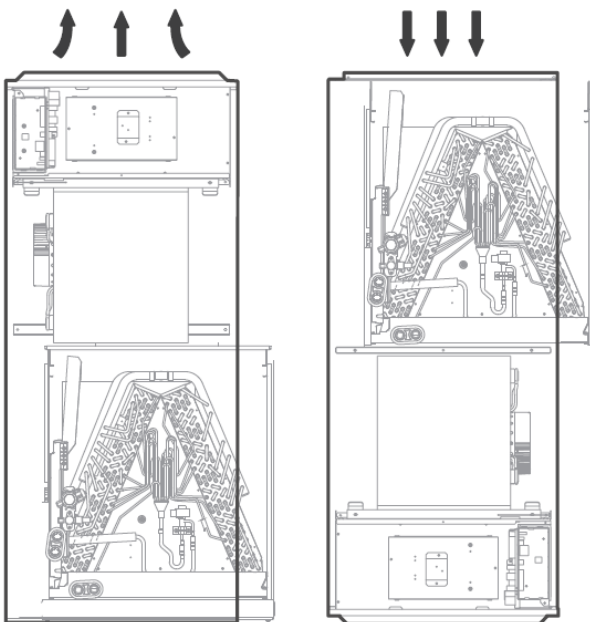

Upflow

Downflow

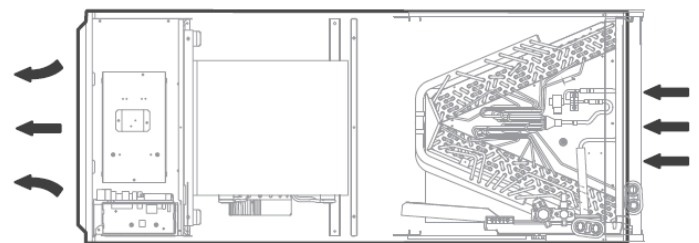

Horizontal left

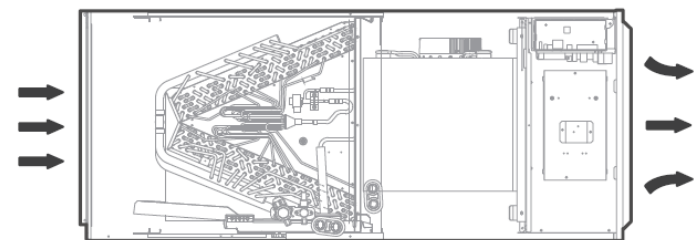

Horizontal right

3 INDOOR UNIT INSTALLATION

3.7 Wire & Piping Connections

Follow these steps to perform a vertical down and horizontal right installation:

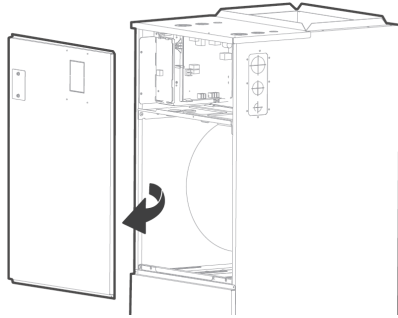

- Step 1:**
Open the upper cover.
- Step 2:**
Open the cover of the electronic control box.
- Step 3:**
Connect the wire according to the wiring diagram.
- Step 4:**
Connect the pipes and install drainage pipes.

3.8 Horizontal Right & Downflow Configurations

The steps below detail the installation of a horizontal left or vertical upflow indoor unit once it has been securely mounted in place.

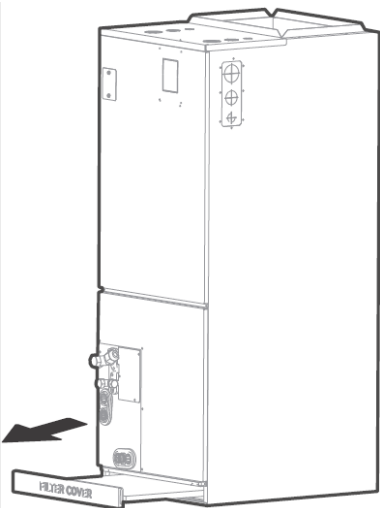

1. Remove the filter door, then remove the filter.

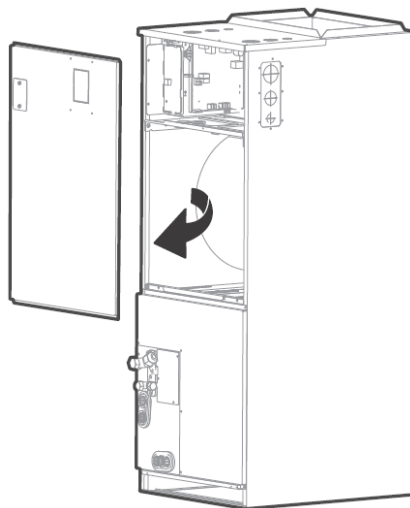

2. Remove the upper cover assembly.

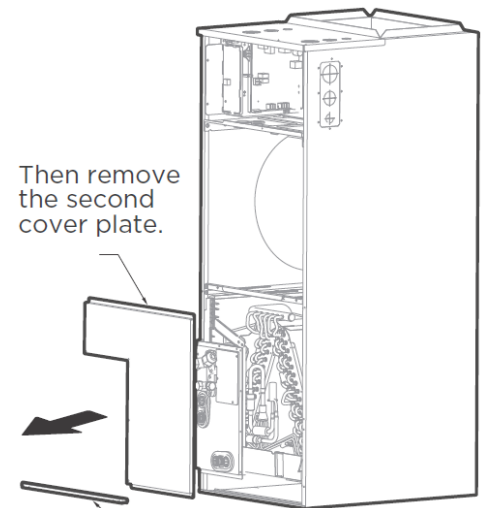

Then remove the second cover plate.

Remove the bottom cover first.

3. Remove evaporator cover plate.

4. Identify the position of the evaporator's temperature sensor.

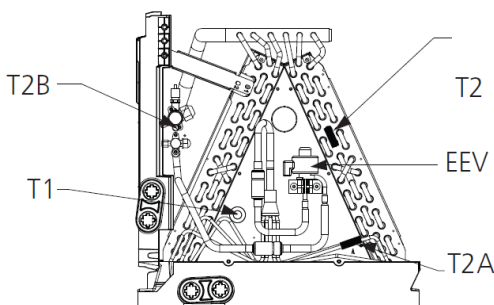

18-24K Model

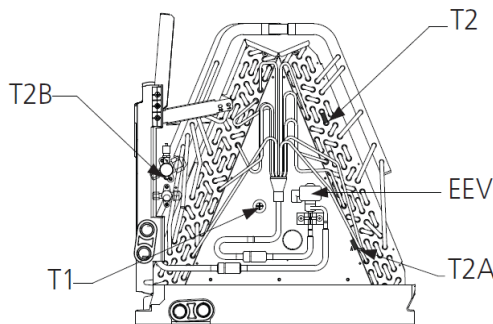

30-36K Model

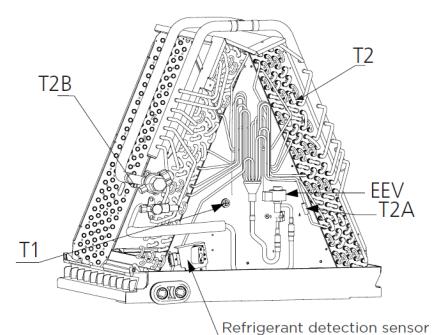

48-60K Model

3 INDOOR UNIT INSTALLATION

5. Unplug temperature sensors T1, T2, T2A, T2B, refrigerant detection sensor, and electronic expansion valve (EEV) from the control board.

T1: IDU room temp. sensor (T1)

T2: IDU coil temp. sensor (T2)

T2A: Evaporator coil temperature sensor (T2A)

T2B: Evaporator coil inlet temperature sensor (T2B)

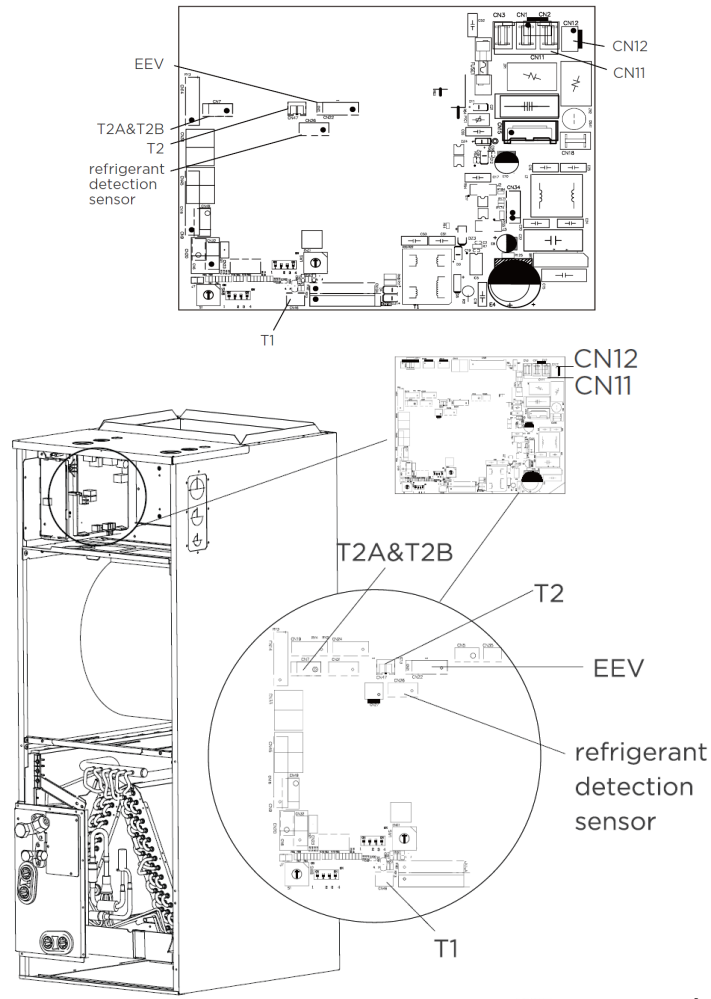

6. Remove T1, T2, T2A, T2B, EEV, & refrigerant detection sensor wire ties.

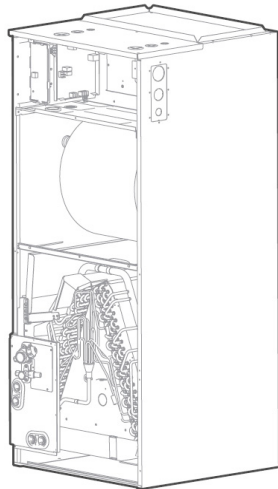

7. Take out the evaporator and drain pan and rotate 180° (when a vertical down configuration is needed).

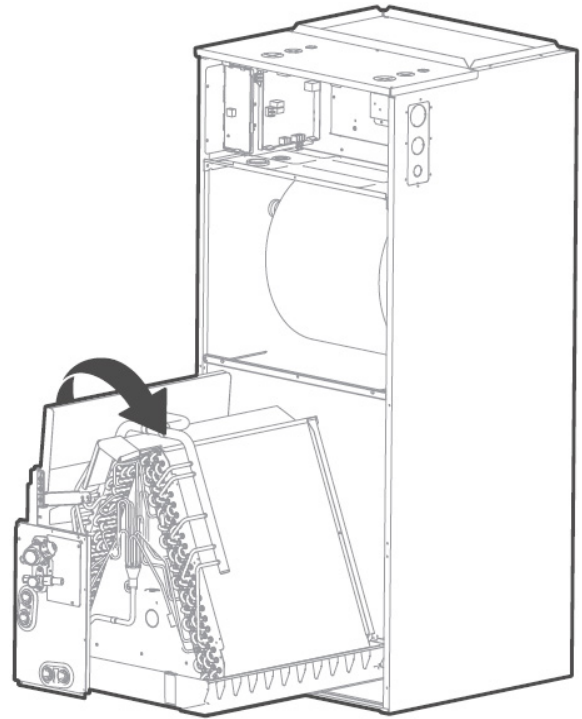

8. Adjust the mounting parts positioning according to the direction of the unit.

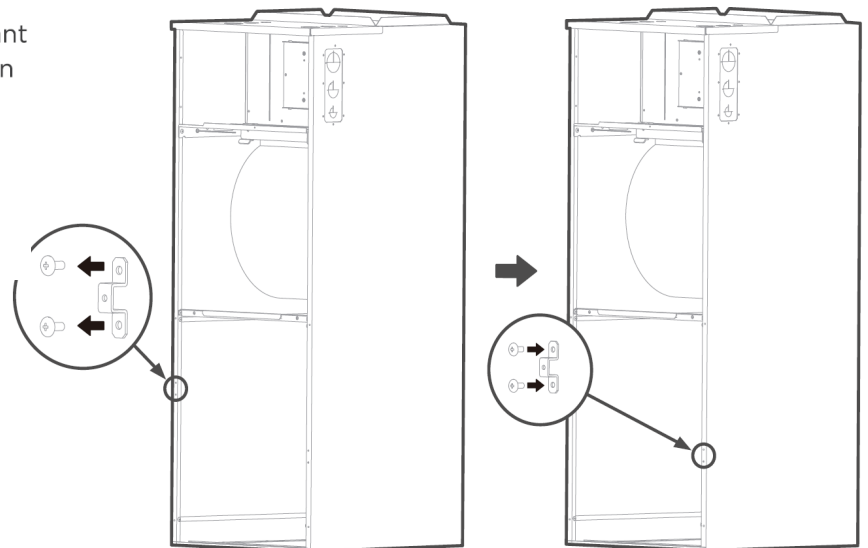

3 INDOOR UNIT INSTALLATION

9. Reinstall the evaporator and drain pan.

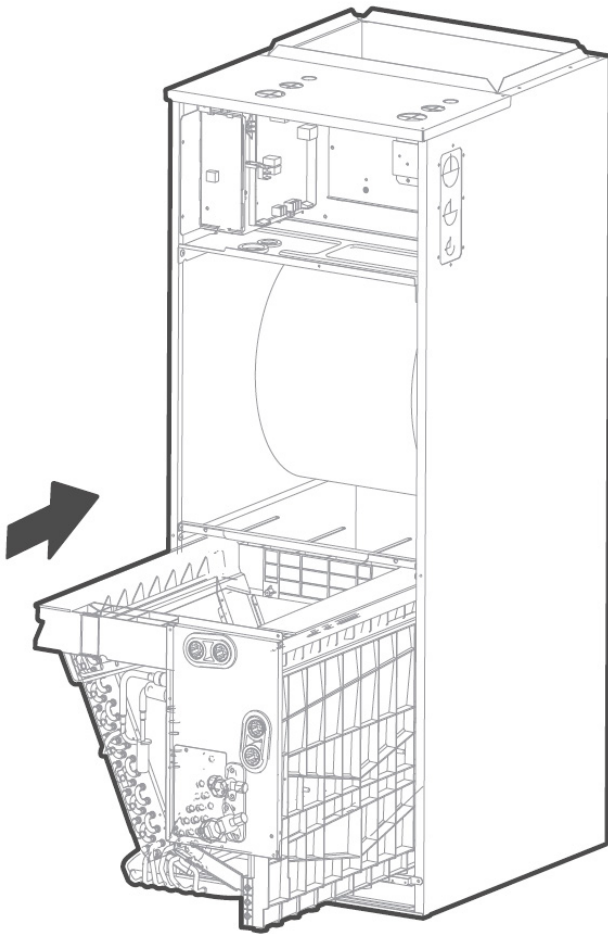

NOTE

The wire body needs to pass through the wire groove from the drain pan and attach to the hook on the drain pan.

10. Reinstall T1, T2, T2A, and T2B sensor plugs and electronic expansion valve (EEV) and tie up the sensor wires. The evaporator is now assembled in place.

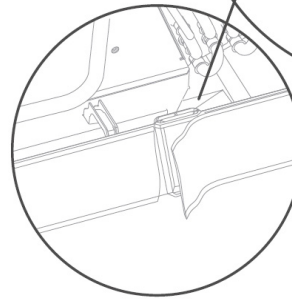
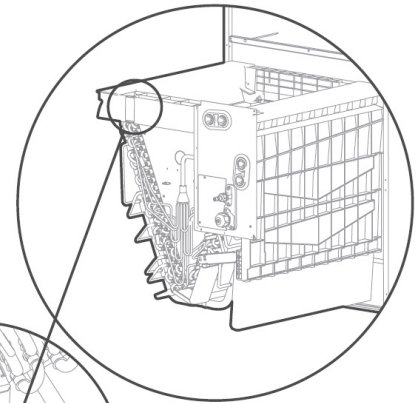

Cut the foam gasket.

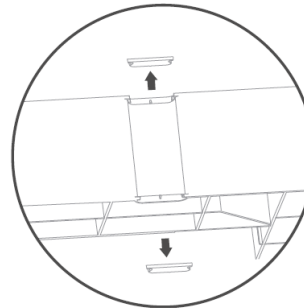

Remove knockouts as shown in the figure.

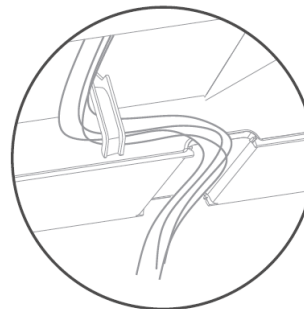

Hook the wire into the buckle and go down from the wire slot.

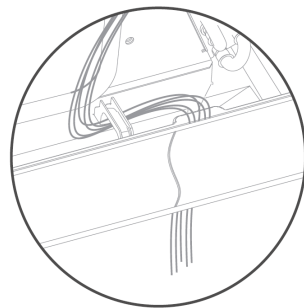

Replace foam gasket over wires.

3 INDOOR UNIT INSTALLATION

11. Use cable ties to attach the room temperature sensor as shown in the figure.

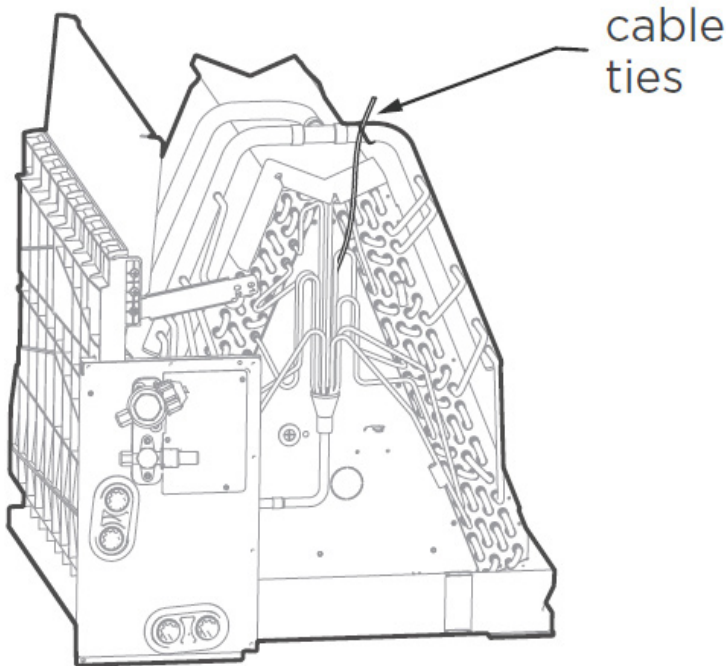

12. Reinstall evaporator cover plate.

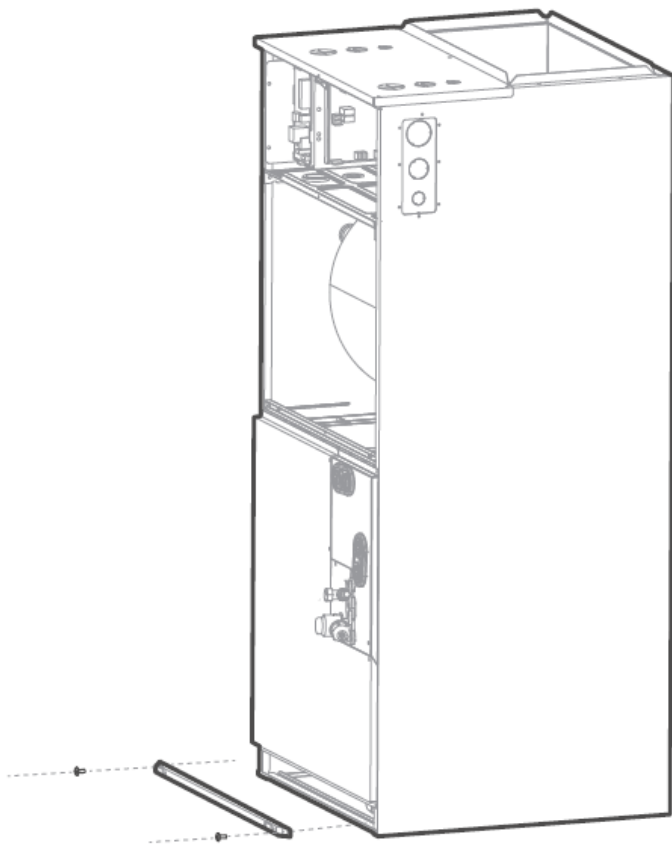

13. Connect the wire according to the wiring diagram.

14. Reassemble the upper cover and reinstall the filter and filter cover plate.

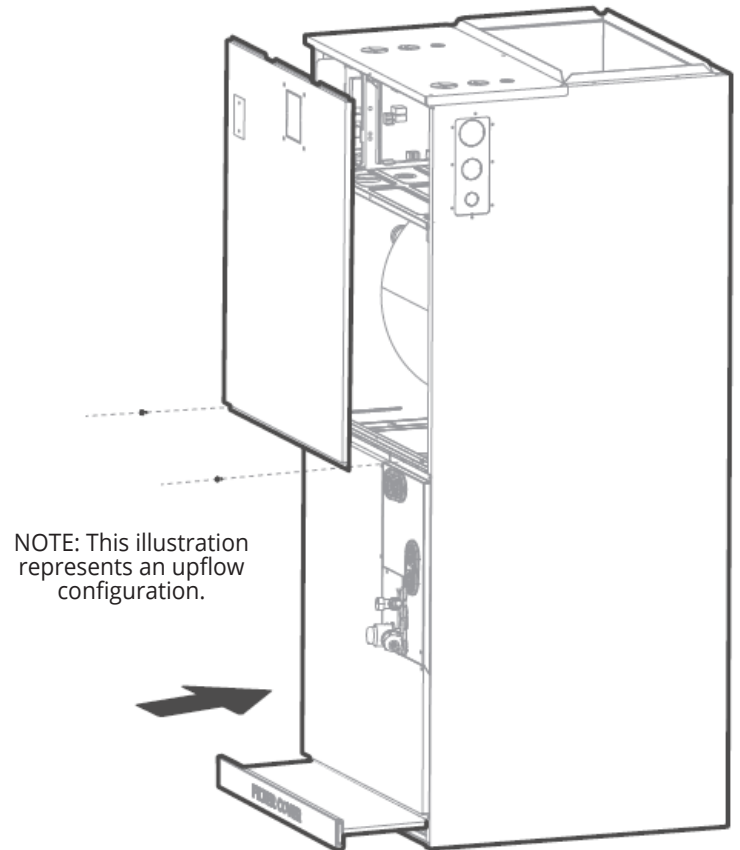

15. Connect the pipes and install drainage pipes.

! CAUTION FOR PIPE INSTALLATION

- Insulate all piping to prevent condensation, which could lead to water damage.
- The drainpipe is used to drain water away from the unit. If the drainpipe is bent or installed incorrectly, water may leak and cause a water-level switch malfunction.
- In HEAT mode, the outdoor unit will discharge water. Ensure that the drain hose is placed in an appropriate area to avoid water damage and icy conditions on walkways.
- **DO NOT** pull the drainpipe forcefully. This could disconnect it.

NOTICE

If installed above a finished living space, a secondary drain pan (as required by many building codes) must be installed under the entire unit and its condensate drain line must be routed where the excess drainage is not in view.

3 INDOOR UNIT INSTALLATION

NOTICE ON PIPE PURCHASING

Installation requires PVC pipe or other suitable material per local and national codes. These can be found at your local hardware store or dealer.

! WARNING

- After removing the drain pan plug(s), check the drain hole(s) to verify that the drain opening is fully clear and free of any debris. Also check to ensure no debris has fallen into the drain pan during installation that could plug the drain opening. Apply sealant around the exiting drain pipe and the liquid and suction lines to prevent the infiltration of humid air.
- On units of this type in which the blower “draws” in air rather than “blows” air through the coil, traps must be installed in the condensate drain lines (primary and auxiliary, if used). Traps prevent the blower from drawing air through the drain lines into the air supply.

3.9 Upflow & Horizontal Left Configurations

The unit operates with a negative pressure at the drain connections and a drain trap is required. The trap must be installed as close to the unit as possible. Make sure the top of the trap is below the connection to the drain pan to allow complete drainage of the pan.

Vertical Discharge

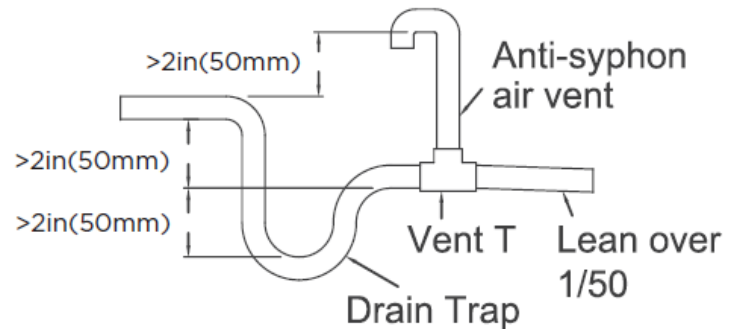
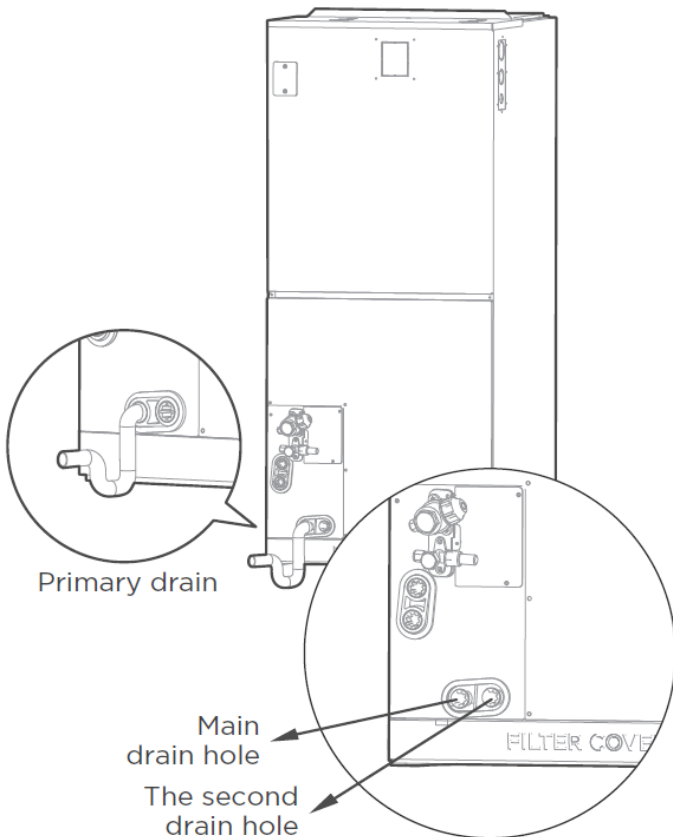

NOTICE

Horizontal runs must also have an anti-siphon air vent (standpipe) installed ahead of the horizontal run to eliminate air trapping.

NOTE ON DRAINPIPE INSTALLATION:

- The figure shows how to trap or plug all drains during vertical discharge.
- The figure shows how to trap or plug all drains during right-hand discharge.
- The seal plug is supplied and should be screwed tightly by hand only.
- Incorrect installation could cause water to flow back into the unit and flood.

! CAUTION

- The drainpipe outlet should be at least 1.9 in (5 cm) above the ground.
- If it touches the ground, the unit may become blocked and malfunction.

4 REFRIGERANT PIPING CONNECTION



WARNING ON REFRIGERANT PIPING

All field piping must be completed by a licensed technician and must comply with all local and national regulations.

- When the air conditioner is installed in a small room, precautions must be taken to prevent the refrigerant concentration in the room from exceeding the safety limit.
- When installing the refrigeration system, ensure that air, dust, moisture, or foreign substances do not enter the refrigerant circuit. Contamination in the system may cause poor operating capacity, high pressure in the refrigeration cycle, explosion, or injury.
- Ventilate the area immediately if there is refrigerant leakage during the installation. Leaked refrigerant gas is both toxic and may be flammable. Ensure there is no refrigerant leakage after completing the installation work.

4.1 Pipe Length & Elevation

Maximum length and drop height

Model Capacity (BTU/H)	Maximum Length of Piping	Maximum Drop Height
18K	98.4 ft (30 m)	65.6 ft (20 m)
24K/30K	164 ft (50 m)	82 ft (25 m)
36K/48K/60K	246 ft (75 m)	98.4 ft (30 m)

Ensure that the length of the refrigerant pipe, the number of bends, and the drop height between the indoor and outdoor units meet the requirements shown in the table:

Name	Model	Pipe Specification		Remark
		Liquid Side	Gas Side	
Connecting Pipe Assembly	18K	Ø3/8in (Ø9.52mm)	Ø3/4in (Ø19mm)	Pipes are not included in the accessories and must be purchased separately from a local dealer.
	24K	Ø3/8in (Ø9.52mm)	Ø3/4in (Ø19mm)	
	30K	Ø3/8in (Ø9.52mm)	Ø3/4in (Ø19mm)	
	36K	Ø3/8in (Ø9.52mm)	Ø3/4in (Ø19mm)	
	48K	Ø3/8in (Ø9.52mm)	Ø3/4in (Ø19mm)	
	60K	Ø3/8in (Ø9.52mm)	Ø3/4in (Ø19mm)	

NOTICE

Both VersaPro® & Hyper Heat units are compatible with MRCOOL® No-Vac® Quick Connect® Pre-Charged Line Sets.



CAUTION-OIL TRAPS

- If oil flows back into the outdoor unit's compressor, this may cause liquid compression or deterioration of the oil return. Oil traps in the rising gas pipe can prevent this.
- For units less than 36,000Btu/h, an oil trap should be installed every 20 ft (6m) of vertical suction line riser.
- For units greater than 36,000Btu/h, an oil trap should be installed every 32.8ft(10m) of vertical suction line riser.

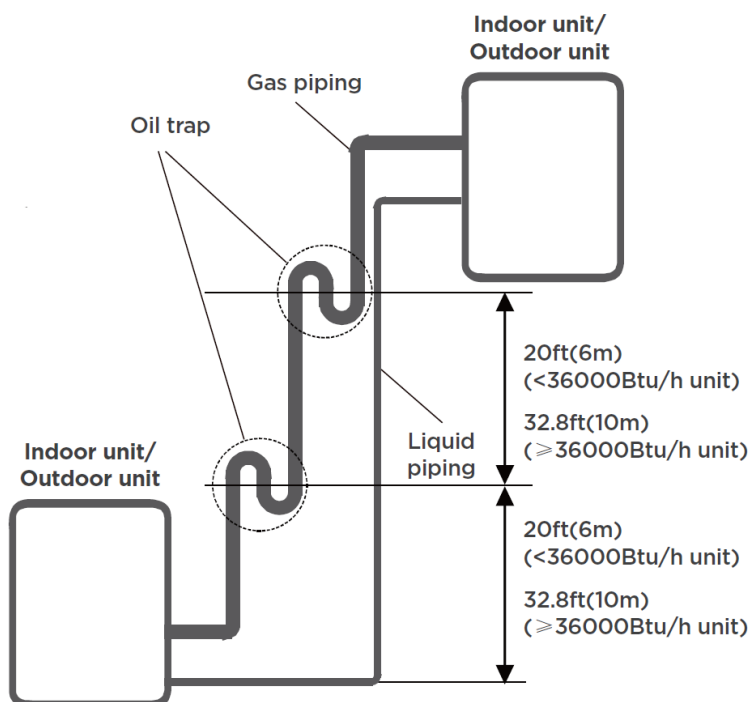

4 REFRIGERANT PIPING CONNECTION

4.2 Refrigerant Line Connection

! CAUTION

Insulate both the gas and liquid piping to prevent condensation.

Air Handler Model	Air Handler Unit Connection (in.flare)		Adapter Required at Indoor Unit (in. flare to braze)	Outdoor Model	Outdoor Unit Connection (in.flare)		Adapter Required at Outdoor Unit (in.flare to flare or braze)
	Liquid	Gas			Liquid	Gas	
18K/24K/30K/ 36K/48K/60K	Liquid	3/8	3/8flare-->3/8braze	18K (VersaPro)	Liquid	3/8	3/8flare-->3/8braze
					Gas	5/8	5/8flare -->3/4flare 5/8flare-->3/4braze
	Gas	3/4	3/4flare-->3/4braze	24K/30K/36K/ 48K/60K	Liquid	3/8	3/8flare-->3/8braze
					Gas	3/4	3/4flare-->3/4braze

Step 1: Cut Pipes

When preparing refrigerant pipes, take extra care to cut and flare them properly. This will ensure efficient operation and minimize the need for future maintenance.

- Measure the distance between the indoor and outdoor units.
- Using a pipe cutter, cut the pipe a little longer than the measured distance.
- Make sure that the pipe is cut at a perfect 90° angle.

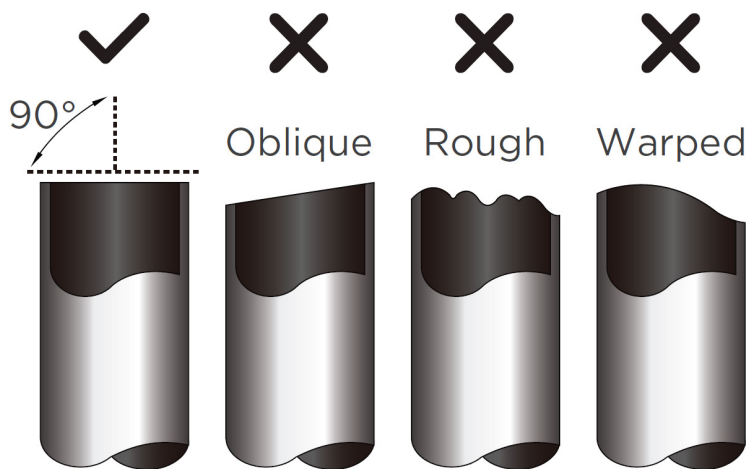

Step 2: Remove Burrs

Burrs can affect the air-tight seal of the refrigerant piping connection. They must be completely removed.

- Hold the pipe at a downward angle to prevent burrs from falling into the pipe.
- Using a reamer or deburring tool, remove all burrs from the cut section of the pipe.

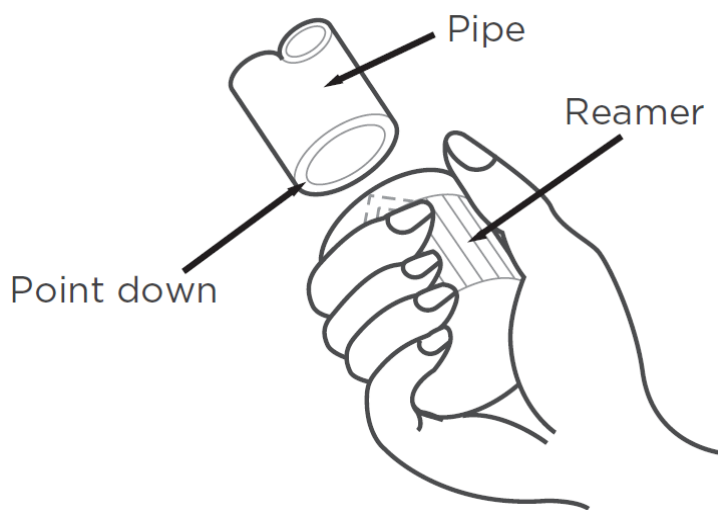

NOTICE

Do not deform pipe while cutting. Be careful not to damage, kink, or deform the pipe while cutting. This will drastically reduce the heating performance.

4 REFRIGERANT PIPING CONNECTION

Step 3: Flare Pipe Ends

Proper flaring is essential to achieve an airtight seal.

- After removing burrs from cut pipe, seal the ends with PVC tape to prevent foreign materials from entering the pipe.
- Sheath the pipe with insulating material.
- Place flare nuts on both ends of the pipe. Make sure they are facing in the right direction, because you can't put them on or change their direction after flaring.
- Remove PVC tape from ends of pipe when ready to perform flaring work.

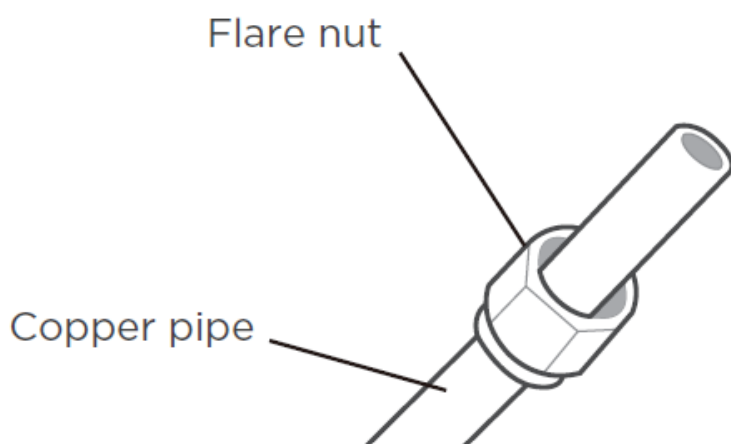

- Clamp flare form on the end of the pipe. The end of the pipe must extend beyond the flare form.

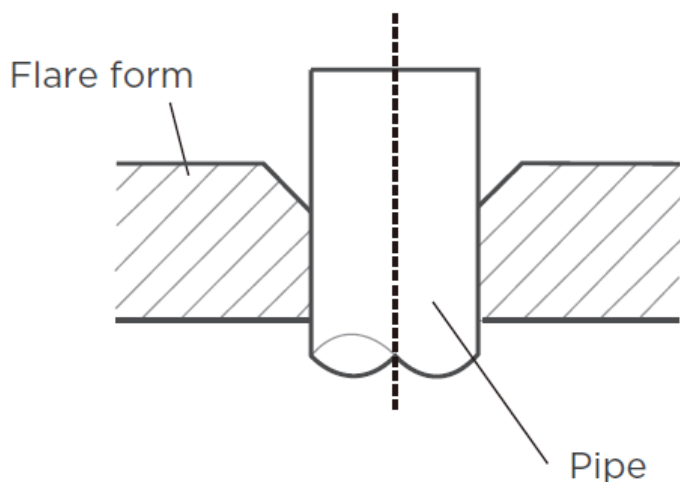

- Place flaring tool onto the form.
- Turn the handle of the flaring tool clockwise until the pipe is fully flared.

Piping Extension Beyond Flare Form

Pipe Gauge	Tightening Torque	Flare Dimension (A)	
		Min.	Max.
Ø3/8in (Ø9.52mm)	32-39 N.m (320-390kgf.cm)	0.52in (13.2mm)	0.53in (13.5mm)
Ø5/8in (Ø16mm)	57-71 N.m (570-710kgf.cm)	0.76in (19.2mm)	0.78in (19.7mm)
Ø3/4in (Ø19mm)	67-101 N.m (670-1010kgf.cm)	0.91in (23.2mm)	0.93in (23.7mm)
Flare Shape			

- Remove the flaring tool and flare form, then inspect the end of the pipe for cracks and even flaring.

Step 4: Connect Pipes

Connect the copper pipes to the indoor unit first, then connect it to the outdoor unit. First connect the low-pressure pipe, then the high pressure pipe.

- When connecting the flare nuts, apply a thin coat of refrigeration oil to the flared ends of the pipes.
- Align the center of the two pipes that you will connect.
- Tighten the flare nut snugly by hand.
- Using a wrench, grip the nut on the unit tubing.
- While firmly gripping the nut, use a torque wrench to tighten the flare nut according to the torque valves in the table above.

4 REFRIGERANT PIPING CONNECTION

NOTICE

Use both a spanner and a torque wrench when connecting or disconnecting pipes to/from the unit.

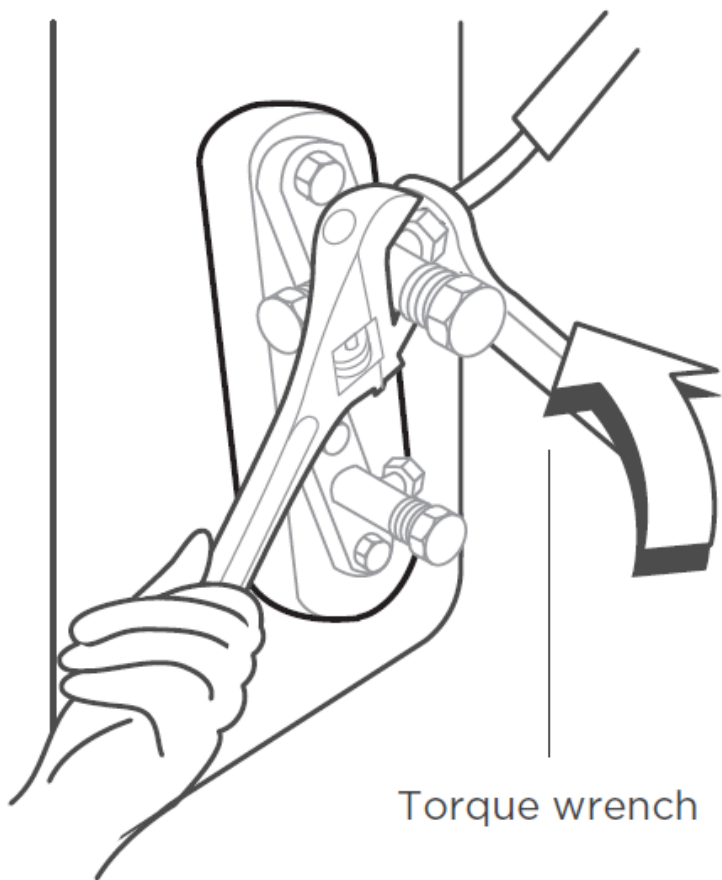

Torque wrench

! CAUTION

Be sure to wrap insulation around the piping. Direct contact with the bare piping may result in burns or frostbite.

- Make sure the pipe is properly connected. Over tightening may damage the bell mouth and under tightening may lead to leakage.

NOTICE

Minimum Bend Radius

Carefully bend the tubing in the middle according to the diagram below. DO NOT bend the tubing more than 90° or more than 3 times.

Use appropriate tool

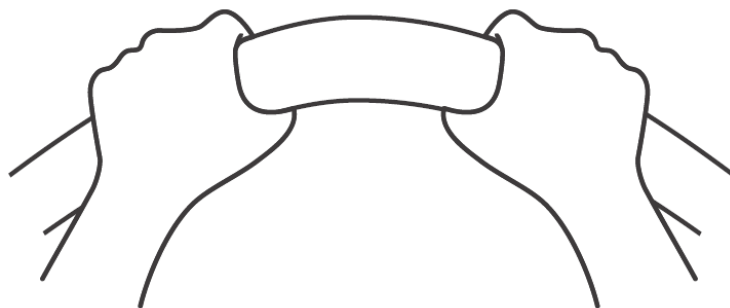

min-radius 10cm(3.9")

- After connecting the copper pipes to the indoor unit, wrap the power cable, signal cable, and the piping together with binding tape.

NOTICE

DO NOT intertwine or cross the signal cable with any other wiring.

- Thread this pipeline through the wall and connect it to the outdoor unit.
- Insulate all the piping, including the valves of the outdoor unit.
- Open the stop valves of the outdoor unit to start the flow of the refrigerant between the indoor and outdoor unit.

! CAUTION

Check to make sure there is no refrigerant leak after completing installation work. If there is a refrigerant leak, ventilate the area immediately and evacuate the system (refer to Air Evacuation section of this manual).

4 REFRIGERANT PIPING CONNECTION

Correct Refrigerant Piping Connecting Installation Methods

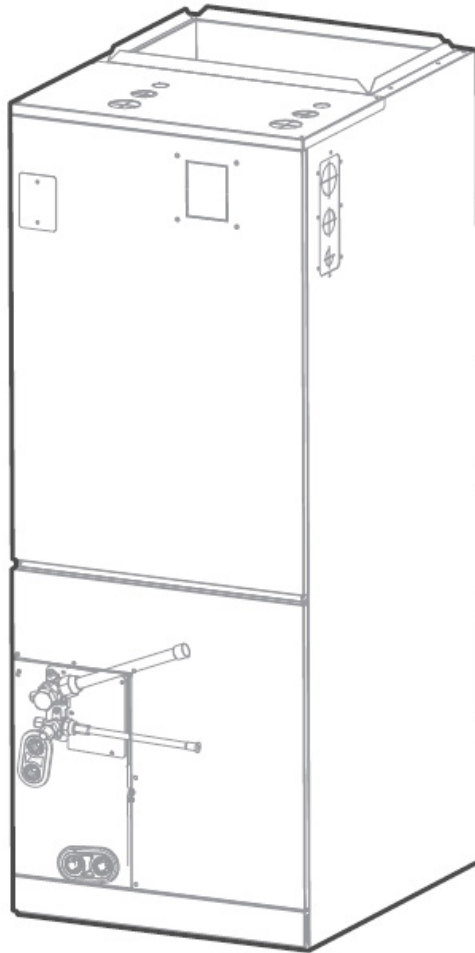

This is not a service valve and cannot be operated during user maintenance or product repair.

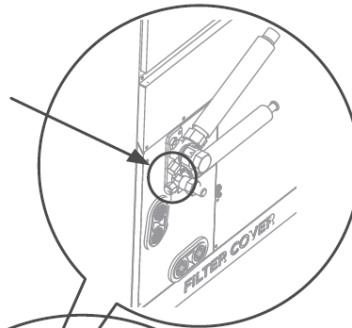

After the unit is installed, wrap the piping and brass fitting with foam tape.

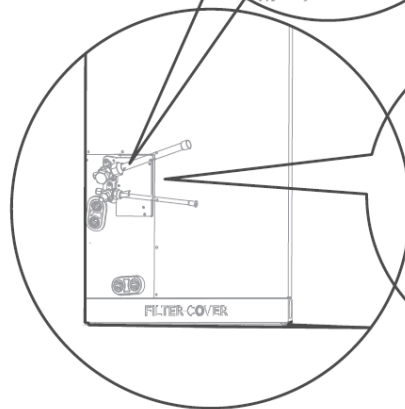

Insulation sleeve

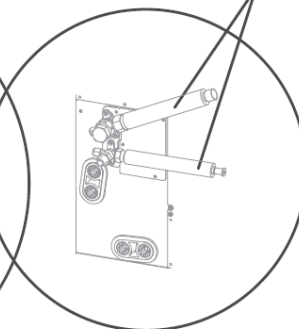

You need to wrap all the connected copper pipes, nuts and other metal parts into the sponge.

5 ELECTRIC HEAT KIT INSTALLATION

5 - Electric Heat Kit Installation

NOTICE

Installation must be performed by a licensed contractor. Please take necessary precautions when performing the installation.

Accessories

Name	Quantity
Manual	1
Foam Gasket	2
Screws	7
Silicone Breaker Cover	1
Electric Auxiliary Heating Wiring Diagram	1
Circuit Breaker Label	1

Model Size Selection

For installations requiring supplemental heating, the optional Electric Auxiliary Heat Module is available in sizes from 5kW to 25kW to accommodate appropriate sizing given the specific heat load and electrical requirements of each installation. Refer to the table below for selection of available sizes of each model, being sure to avoid improper matching.

Model (Btu/h)	5kW	8kW	10kW	15kW	20kW
18K	Y	Y	Y	-	-
24K	Y	Y	Y	Y	-
30K	Y	Y	Y	Y	-
36K	Y	Y	Y	Y	Y
48K	-	Y	Y	Y	Y
60K	-	-	Y	Y	Y

NOTICE

Only use compatible modules certified for use with the model. Refer to the Electric Auxiliary Heat Model specification for additional details to ensure proper selection and installation.

Installation Preparation

Before installation, confirm the electric auxiliary heat module and supplied accessories are present and free of damage. Do not attempt to install if damage is present.

Electric Auxiliary Heat Module Installation and Wiring Operation

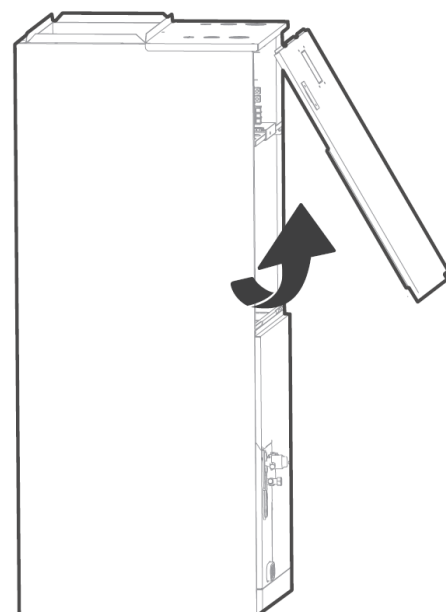

Step 1:
Open the upper cover.

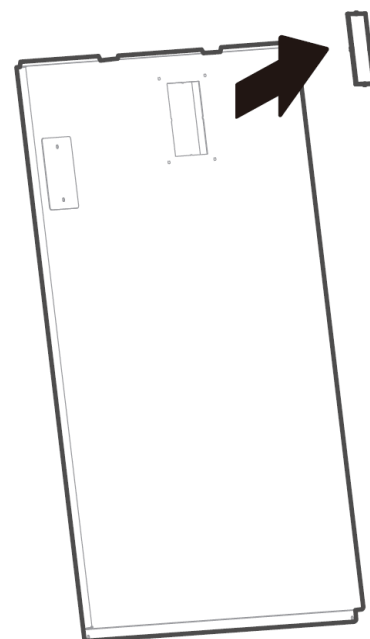

Step 2:
Use tools to remove the knock-out holes of the upper cover.

5 ELECTRIC HEAT KIT INSTALLATION

Step 3:

Remove the terminal block and power wires, loosen the screws, and remove the electric auxiliary heating cover.

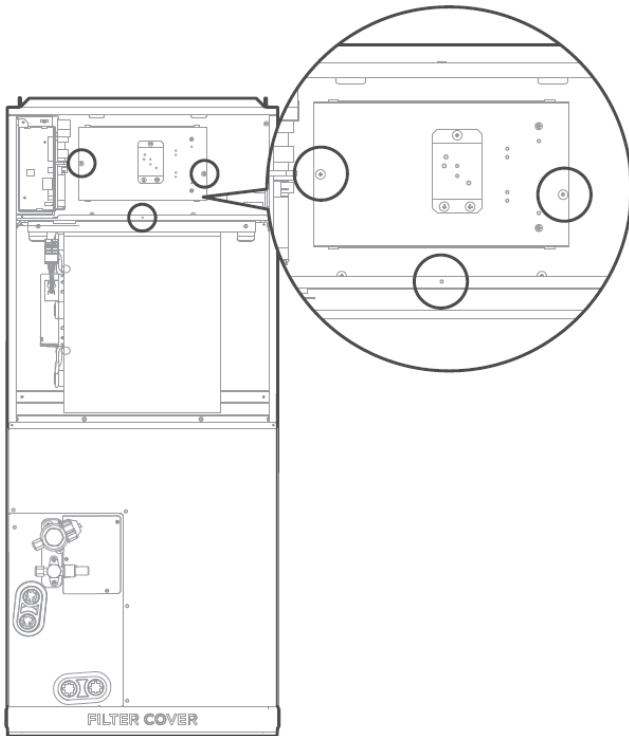

Step 4:

Install the electric auxiliary heating assembly through the front, and note that the support assembly must lock into the support holes in the back of the cabinet.

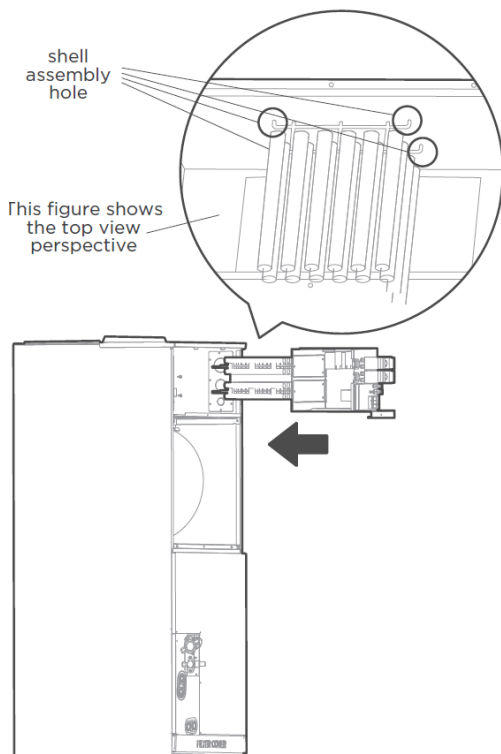

Step 5:

Tighten the mounting screws.

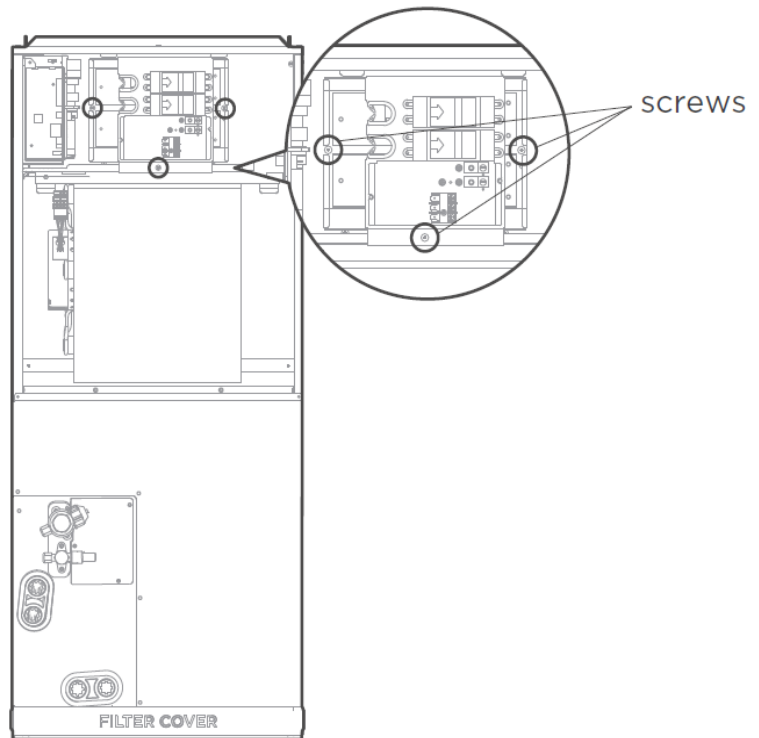

Step 6:

Wire according to the wiring nameplate. Apply the wiring diagram to the inside cover for future reference and maintenance. Plug the electric heating plugs CN11 and CN12 into the main board.

Step 7:

Install the upper cover and the silicone breaker cover.

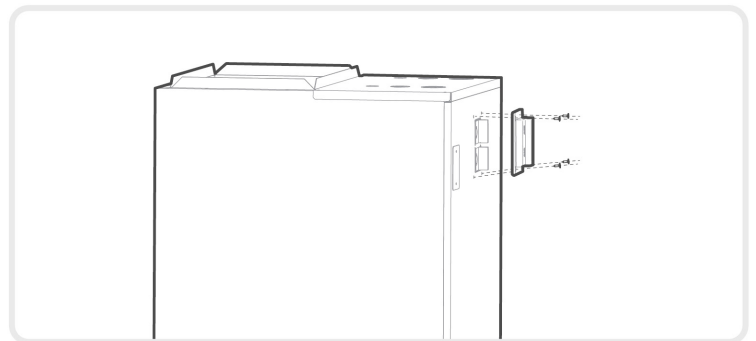

Step 8:

After installing the electric auxiliary heat module, apply the circuit breaker label near the silicone breaker cover previously installed.

NOTICE

The circuit breaker cannot be operated by user.

6 CONFIRMATION OF INDOOR UNIT

6.1 Units with Electrical Heat

NOTICE

- The electric auxiliary heating wiring diagram is packed with the accessories.
- If the branch circuit wire length exceeds 100ft, consult NEC 210-19a to determine maximum wire length.
- Use 2% voltage drop.

After the electric heating wiring is connected, please confirm the following before powering on:

- Check and ensure a secure connection of all wiring.
- Ensure that the wire size is properly selected per NEC or local codes.

Model	Number of Circuit Breakers	Number of Relays	Number of Power Cord Groups	Number of Power Cord Grounding Screws
5kW	1	1	2	2
8kW	1	2	2	2
10kW	1	2	2	2
15kW	2	3	3	3
20kW	2	4	3	3

6.2 Units without Electrical Heat

Unit Size	Volts-Phase	Rated Current (A)	Minimum Circuit Amps	Branch Circuit	
				Minimum Wire Size AWG	Fuse/Circuit Breaker Amps
18K	115/208/230V-1	115V: 4.4A	115V: 5.5A	14#	15.0
		208/230V: 3.0A	208/230V: 4.0A		
24K	115/208/230V-1	115V: 4.4A	115V: 5.5A	14#	15.0
		208/230V: 3.0A	208/230V: 4.0A		
30K	115/208/230V-1	115V: 6.4A	115V: 8.0A	14#	15.0
		208/230V: 4.5A	208/230V: 6.0A		
36K	115/208/230V-1	115V: 6.4A	115V: 8.0A	14#	15.0
		208/230V: 4.5A	208/230V: 6.0A		
48K	115/208/230V-1	115V: 11.5A	115V: 14.5A	14#	15.0
		208/230V: 8.3A	208/230V: 11.0A		
60K	115/208/230V-1	115V: 11.5A	115V: 14.5A	14#	15.0
		208/230V: 8.3A	208/230V: 11.0A		

Use copper wire only to connect the unit. If other than uncoated (non-plated) 75°C copper wire (solid wire for 10 AWG and smaller, stranded wire for larger than 10 AWG) is used, consult applicable tables of the National Electric Code (ANSI/NFPA 70).

NOTICE

The specification may be different between different models. Refer to the indoor unit's nameplate. Choose the cable type according to the local electrical codes and regulations. Choose the correct cable size according to the Minimum Circuit Ampacity indicated on the nameplate of the unit.

6.3 Auxiliary Heater Electrical Data

Heater Model	Heater kW	Internal Circuit Protection	Circuit 1 208/230V			Circuit 2			Circuit 2		
			Heater Amps	MCA (1)	MOP (2)	Heater Amps	MCA (1)	MOP (2)	Heater Amps	MCA (1)	MOP (2)
MVPHK05	5	Ckt Bkr	18.0/20.0	23.0/27.0	25.0/30.0	/	/	/	/	/	/
MVPHK08	8	Ckt Bkr	28.8/32.0	37.0/42.0	40.0/45.0	/	/	/	/	/	/
MVPHK10	10	Ckt Bkr	36.0/40.0	46.0/53.0	50.0/60.0	/	/	/	/	/	/
MVPHK15	15	Ckt Bkr	18.0/20.0	23.0/27.0	25.0/30.0	36.0/40.0	46.0/53.0	50.0/60.0	/	/	/
MVPHK20	20	Ckt Bkr	36.0/40.0	46.0/53.0	50.0/60.0	36.0/40.0	46.0/53.0	50.0/60.0	/	/	/

6 CONFIRMATION OF INDOOR UNIT

6.4 Electric Auxiliary Heating Wiring Diagrams

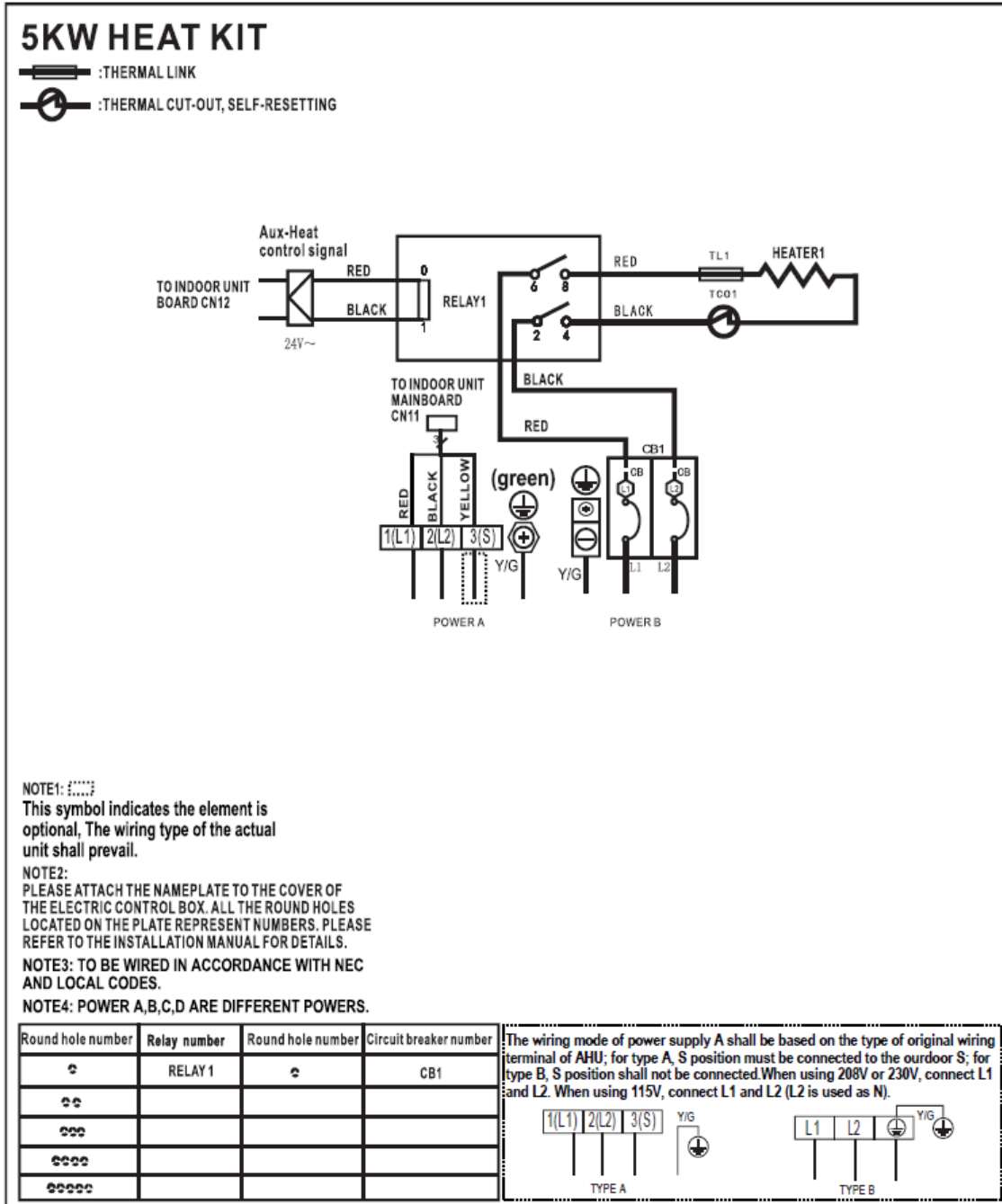

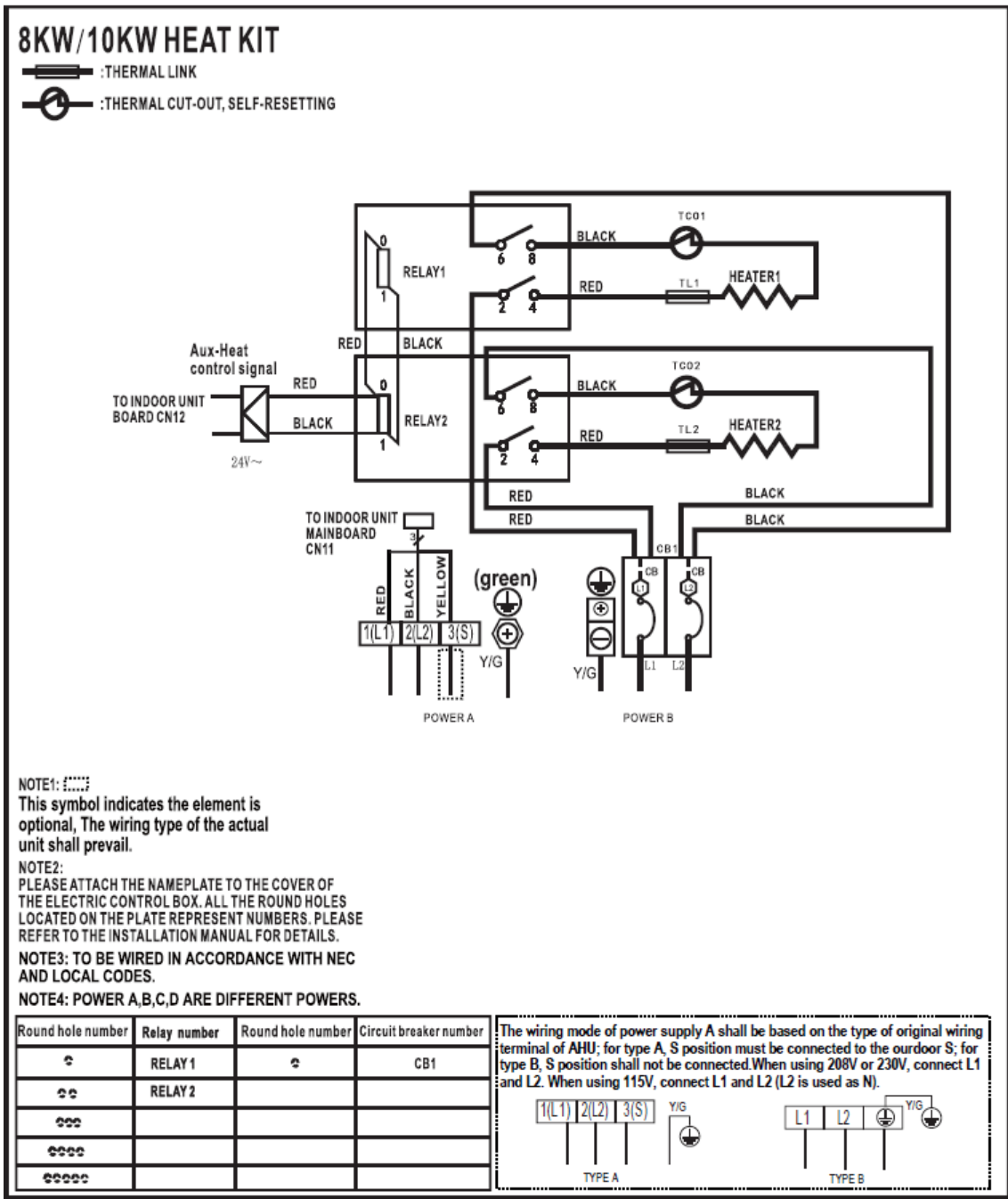

6 CONFIRMATION OF INDOOR UNIT



6 CONFIRMATION OF INDOOR UNIT

15KW HEAT KIT

 : THERMAL LINK
 : THERMAL CUT-OUT, SELF-RESETTING

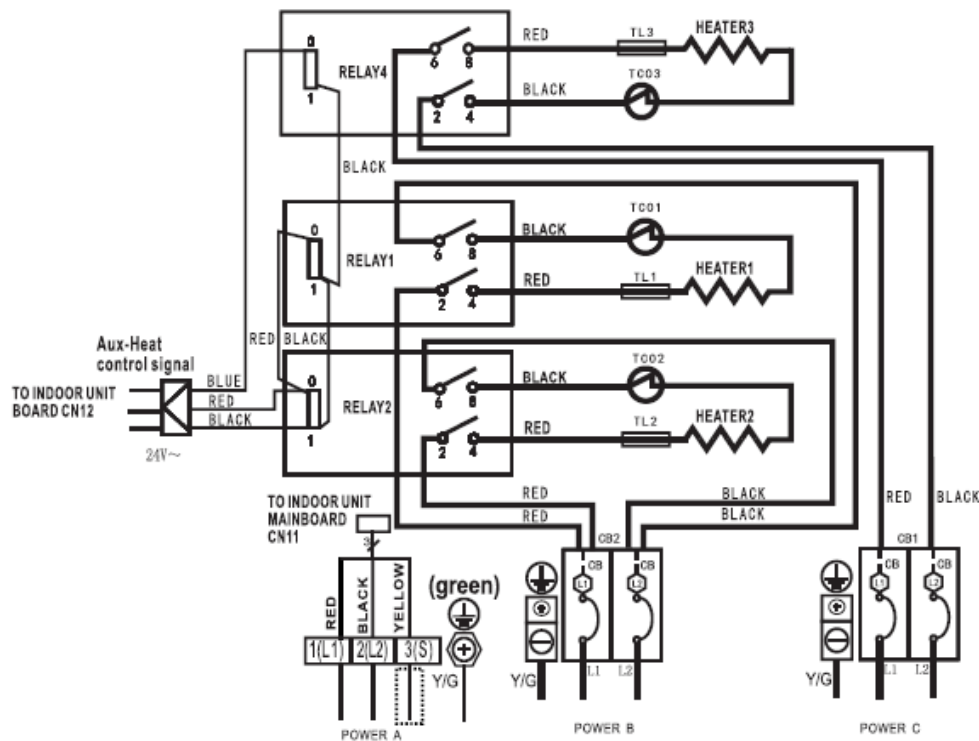

NOTE1: 







This symbol indicates the element is optional. The wiring type of the actual unit shall prevail.

NOTE2:

PLEASE ATTACH THE NAMEPLATE TO THE COVER OF THE ELECTRIC CONTROL BOX. ALL THE ROUND HOLES LOCATED ON THE PLATE REPRESENT NUMBERS. PLEASE REFER TO THE INSTALLATION MANUAL FOR DETAILS.

NOTE3: TO BE WIRED IN ACCORDANCE WITH NEC AND LOCAL CODES.

NOTE4: POWER A,B,C,D ARE DIFFERENT POWERS.

Round hole number	Relay number	Round hole number	Circuit breaker number
	RELAY 1		CB1
	RELAY 2		CB2
			
	RELAY 4		
			

The wiring mode of power supply A shall be based on the type of original wiring terminal of AHU; for type A, S position must be connected to the outdoor S; for type B, S position shall not be connected. When using 208V or 230V, connect L1 and L2. When using 115V, connect L1 and L2 (L2 is used as N).



6 CONFIRMATION OF INDOOR UNIT

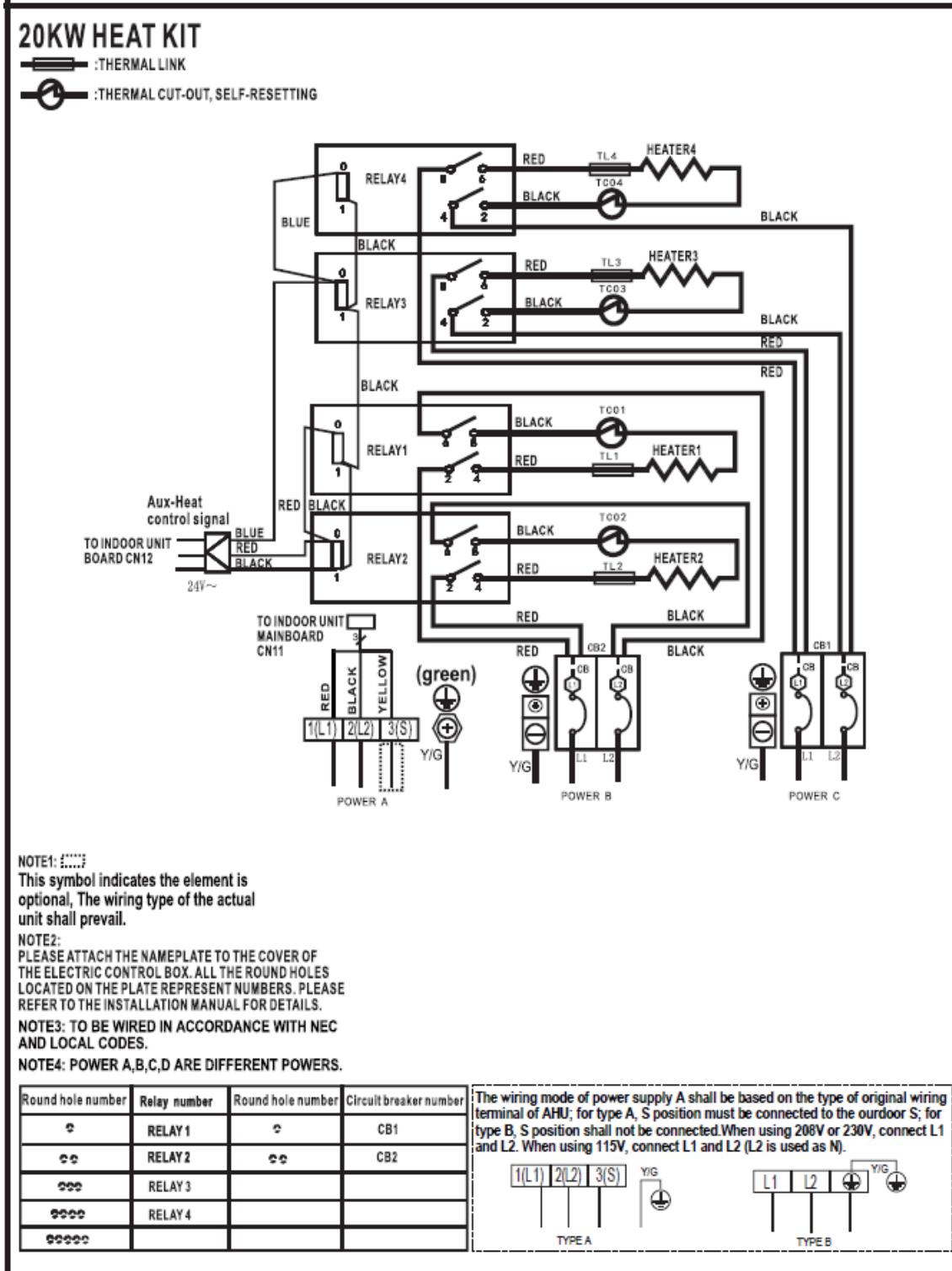

7 OUTDOOR UNIT INSTALLATION

NOTICE

Install the unit by following local switch regulations. These may differ slightly between different regions.

7.1 Location Selection

Before installing the outdoor unit, you must choose an appropriate location. The following are standards to help choose an appropriate location for the unit.

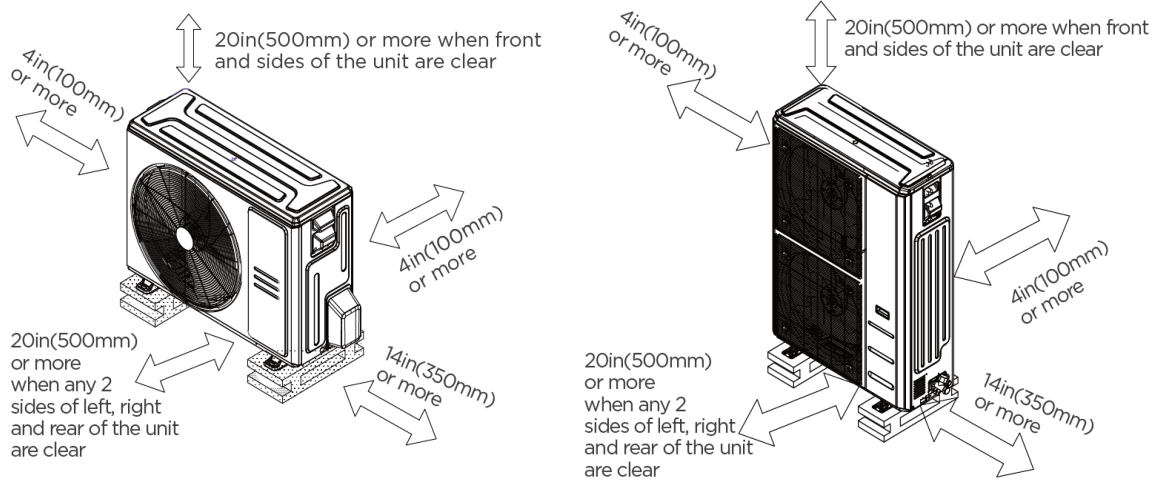

Meets all spatial requirements shown in installation Space Requirements above.



Firm & Solid--the location can support the unit and will not vibrate.



Noise from the unit will not disturb other people.

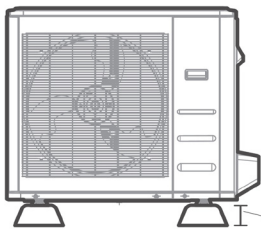

The outdoor unit must be installed on riser of at least 6in (15cm) in height or per local code to get the unit above local mean snow fall.



Good air circulation and ventilation.



Where snowfall is anticipated, take appropriate measures to prevent ice buildup and coil damage.

7 OUTDOOR UNIT INSTALLATION

Do NOT install the unit in the following locations:

- ⊗ Near an obstacle that will block air inlets and outlets.
- ⊗ In a location that is exposed to large amounts of dust.
- ⊗ Near animals or plants that will be harmed by hot air discharge.
- ⊗ Near any source of combustible gas.
- ⊗ Near a public street, crowded areas, or where noise from the unit can disturb others.

! CAUTION FOR EXTREME WEATHER

If the unit is exposed to heavy wind, install so that the air outlet fan is at a 90° angle to the direction of the wind. If needed, build a barrier in front of the unit to protect it from extremely heavy winds. See figures below. **If the unit is frequently exposed to heavy rain or snow**, build a shelter above the unit to protect it from the rain or snow. Be careful not to obstruct air flow around the unit.

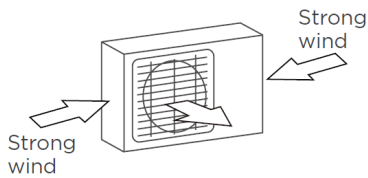

90° angle to the direction of the wind

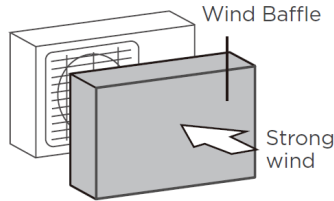

Build a wind Baffle to protect the unit

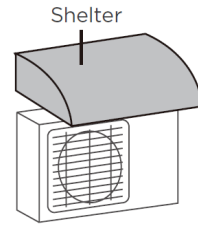

Build a shelter to protect the unit

7.2 Drain Fitting

Step 1:

Find the base pan hole on the outdoor unit.

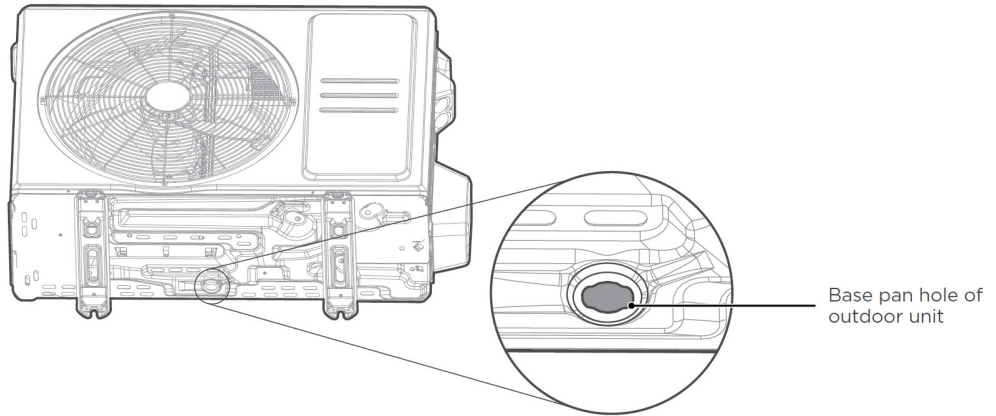

Step 2:

- Fit the rubber seal on the end of the drain fitting that will connect to the outdoor unit.
- Insert the drain fitting into the hole in the base pan of the unit. The drain fitting will click into place.
- Connect a drain hose extension (not included) to the drain fitting to redirect water from the unit during heating mode.

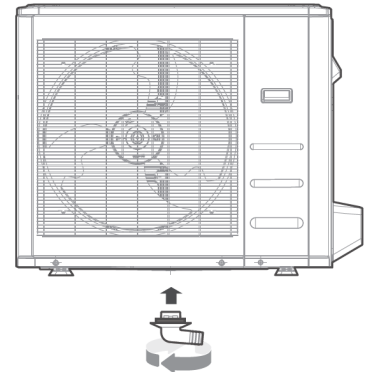
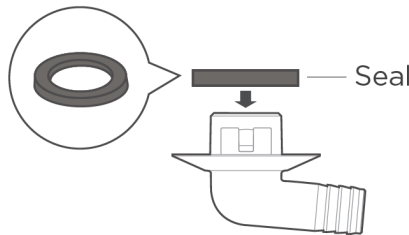

IN COLD CLIMATES

In cold climates, make sure that the drain hose is as vertical as possible to ensure swift water drainage. If water drains too slowly, it can freeze inside the hose and flood the unit.

7 OUTDOOR UNIT INSTALLATION

7.3 Anchor Outdoor Unit

The outdoor unit can be anchored to the ground or to a wall-mounted bracket with an M10 bolt. Prepare the installation base of the unit according to the dimensions below.

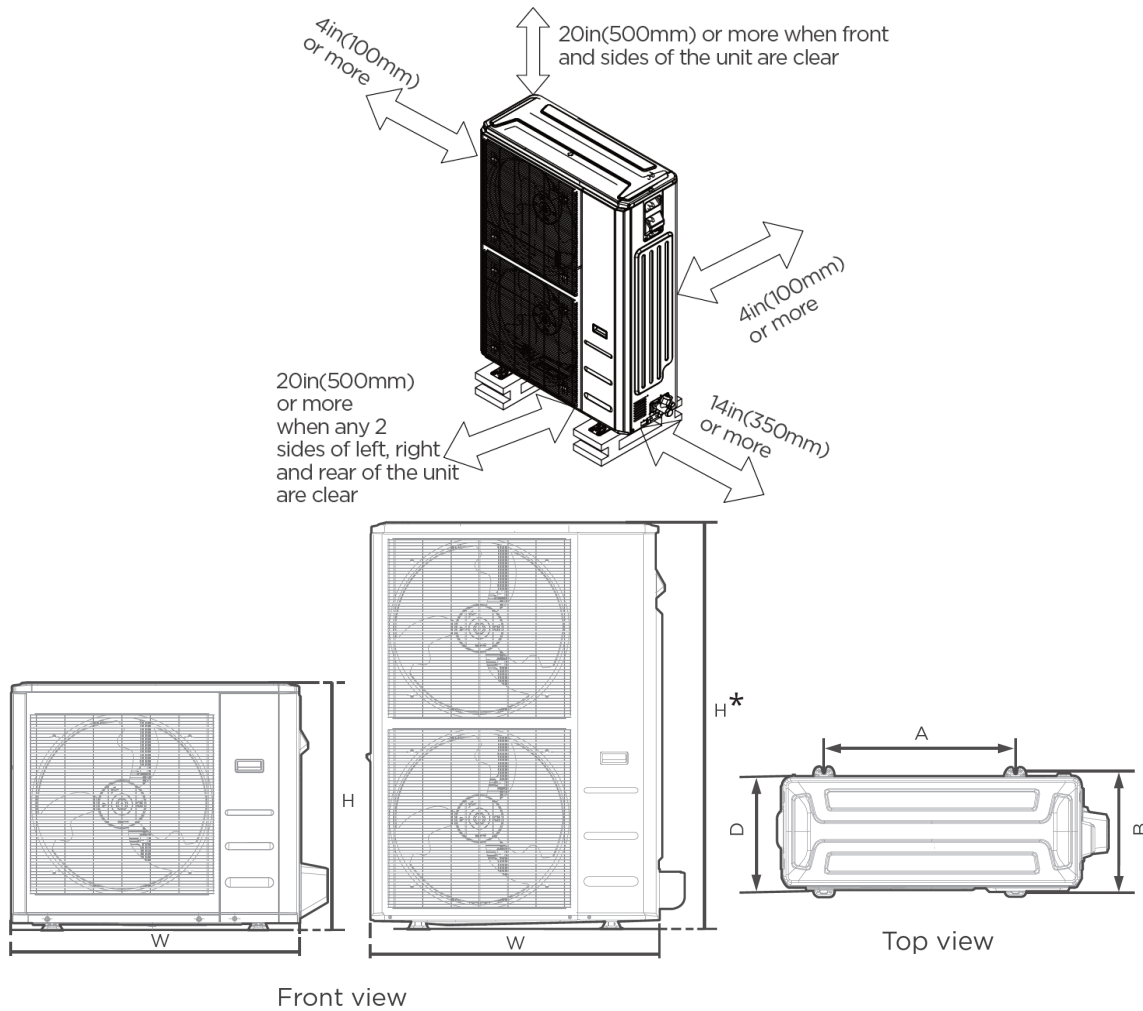

VersaPro® Models	Outdoor Unit Dimensions						Mounting Dimensions			
	W		H		D		A		B	
	mm	inch	mm	inch	mm	inch	mm	inch	mm	inch
18K	805	31-11/16	554	21-13/16	330	13	511	20-1/8	317	12-1/2
24K	890	35	673	26-1/2	342	13-15/32	663	26-1/8	354	13-15/16
30/36K	946	37-1/4	810	31-29/32	410	16-5/32	673	26-1/2	403	15-7/8
48K/60K	980	38-19/32	975	38-3/8	415	16-11/32	616	24-1/4	397	15-5/8

Hyper Heat Models:	Outdoor Unit Dimensions						Mounting Dimensions			
	W		H		D		A		B	
	mm	inch	mm	inch	mm	inch	mm	inch	mm	inch
24K	890	35	673	26 1/2	342	13 1/2	663	26 1/8	354	13 15/16
30K	946	37 1/4	810	31 7/8	410	16 1/8	673	26 1/2	403	15 7/8
36K/48K	980	38 1/2	975	38 3/8	415	16 1/4	616	24 1/4	397	15 5/8
60K*	952	37 1/2	1330	52 3/8	415	16 1/4	634	15 29/32	404	15 7/8

*Double-stack unit applies to 60K Hyper Heat model only.

7 OUTDOOR UNIT INSTALLATION

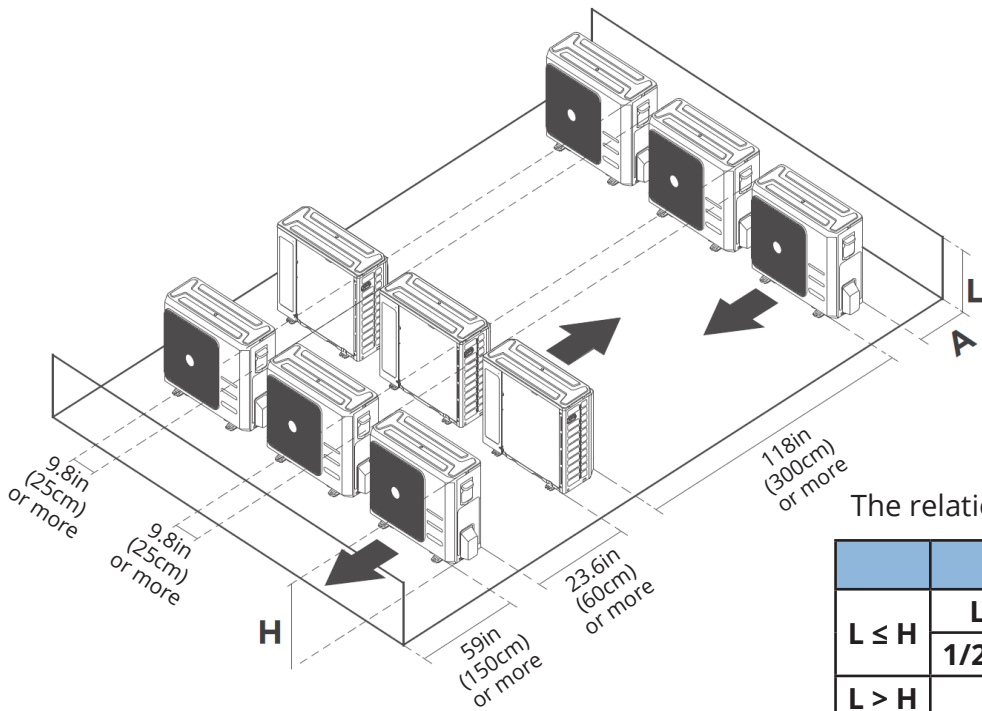

Rows of Series Installation

The relations between H, A, and L are as follows:

	L	A
L ≤ H	L ≤ 1/2H	25cm / 9-13/16in or more
	1/2H < L ≤ H	30cm / 11-13/16in or more
L > H	Cannot be installed	

If installing the unit on the ground or concrete mounting platform, do the following:

- Mark the positions for four expansion bolts based on the dimensions chart.
- Pre-Drill holes for expansion bolts.
- Place a nut on the end of each expansion bolt.
- Hammer expansion bolts into the pre-drilled holes.
- Remove the nuts from expansion bolts, and place the outdoor unit on bolts.
- Put a washer on each expansion bolt, then replace the nuts.
- Using a wrench, tighten each nut until snug.



WARNING

WHEN DRILLING INTO CONCRETE, EYE PROTECTION IS RECOMMENDED AT ALL TIMES.

If installing the unit on a wall-mounted bracket, do the following:

- Mark the position of the bracket holes based on the dimensions chart.
- Pre-Drill holes for expansion bolts.
- Place a washer and nut on the end of each expansion bolt.
- Thread expansion bolts through the holes in the mounting brackets, put mounting brackets into position, and hammer the expansion bolts into the wall.
- Check that the mounting brackets are level.
- Carefully lift the unit and place its mounting feet on brackets.
- Bolt the unit firmly to the brackets.
- If allowed, install the unit with rubber isolator pads to reduce vibrations and noise.



CAUTION

Make sure the wall is made of solid brick, concrete, or of similarly strong material. The wall must be able to support at least four times the weight of the unit.

8 ELECTRICAL CONNECTIONS

8.1 Wiring Precautions



WIRING WARNINGS

Before performing any electrical work, read these warnings:

- **BEFORE PERFORMING ANY ELECTRICAL OR WIRING WORK, TURN OFF THE MAIN POWER TO THE SYSTEM.**
- All wiring must comply with local and national electrical codes, regulations, and must be installed by a licensed electrician.
- All electrical connections must be made according to the Electrical Connection Diagram located on the panels of the indoor and outdoor units.
- If there is a serious safety issue with the power supply, stop work immediately. Do not resume the install until the safety issue is properly resolved.
- Power voltage should be within 90-110% of rated voltage. Insufficient power supply can cause malfunction, electrical shock, or fire.
- Installation of an external surge suppressor at the outdoor disconnect is recommended.
- If connecting power to fixed wiring, a switch or circuit breaker that disconnects all poles and has a contact separation of at least 1/8in (3mm) must be incorporated in the fixed wiring. The qualified technician must use an approved circuit breaker or switch.
- Only connect the unit to an individual branch circuit. Do not connect another appliance to that circuit.
- Make sure to properly ground the unit.
- Every wire must be firmly connected. Loose wiring can cause the terminal to overheat, resulting in product malfunction and possible fire.
- Do not let wires touch or rest against refrigerant tubing, the compressor, or any moving parts within the unit.
- To avoid getting electric shock, never touch the electrical components soon after the power supply has been turned off. After turning off the power, always wait 10 minutes or more before you touch the electrical components.
- Ensure electrical wiring does not cross with signal wiring. This may cause distortion, interference, or possibly damage the circuit boards.
- No other equipment should be connected to the same power circuit.
- Connect the outdoor wires before connecting the indoor wires.

8.2 Wiring Overview

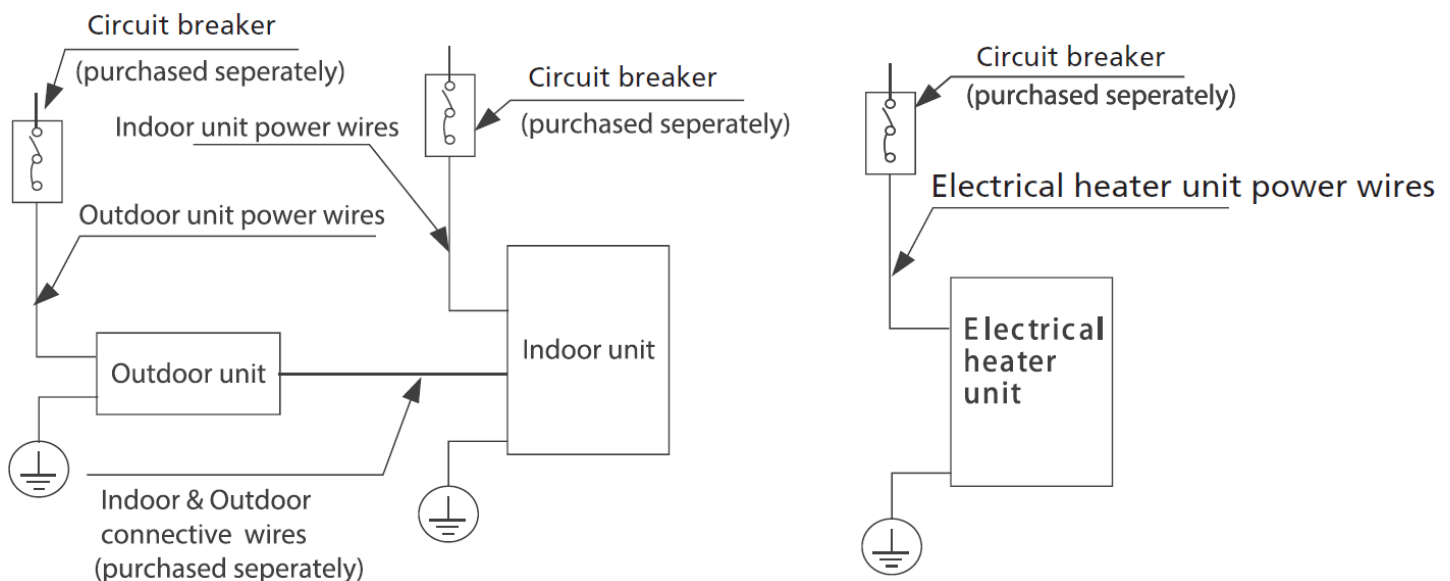

The diagrams are for explanation purpose only. Individual units may be slightly different. The actual diagram shall prevail.

8.3 Outdoor Unit Wiring

! WARNING

BEFORE PERFORMING ANY ELECTRICAL OR WIRING WORK, TURN OFF THE MAIN POWER TO THE SYSTEM.

Prepare the cable for connection

Step 1:

1. Choose the right cable size according to the local electrical codes and regulations, and the Minimum Circuit Ampacity indicated on the unit nameplate.
2. Using wire strippers, strip the jacket from the both ends of the signal cable to reveal approximately 5.9in (15cm) of wire.
3. Strip the insulation from the ends.
4. Stranded wire requires u-lugs or ring terminals to be crimped onto the ends of the wire.

NOTICE

- When connecting the wires, strictly follow the wiring diagram found inside the electrical box cover.
- Choose the cable type according to the local electrical switches and regulations.
- Choose the right cable size according to the Minimum Circuit Ampacity indicated on the nameplate of the unit.

Step 2:

Remove the electrical box cover of the outdoor unit. If there is no cover on the outdoor unit, take off the bolts from the maintenance board and remove the protection board.

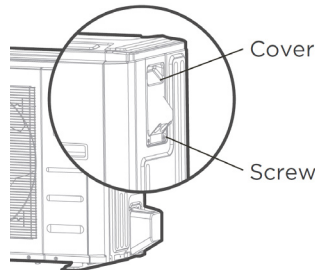

! WARNING

- RISK OF ELECTRIC SHOCK CAN CAUSE INJURY OR DEATH. DISCONNECT ALL REMOTE ELECTRIC POWER SUPPLIES BEFORE SERVICING.
- ISOLATE THE POWER SUPPLY LEADS AND COMMUNICATION LEADS BY THE STRAIN RELIEF AND KEEP POWER SUPPLY LEADS AWAY FROM COMMUNICATION LEADS.

Step 3:

1. Match the wire colors/ labels with the labels on the terminal block. Firmly screw the u-lug of each wire to its corresponding terminal.

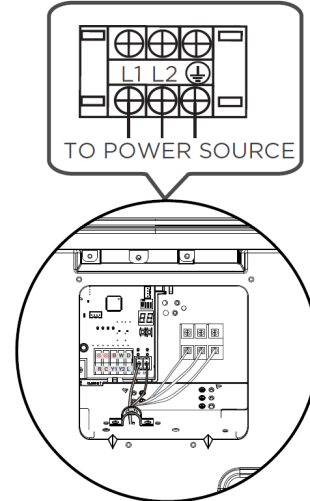
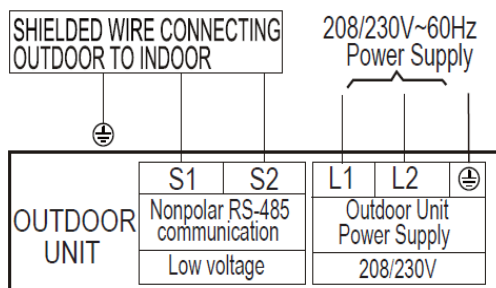

2. Clamp down the cable with the cable clamp.
3. Insulate unused wires with electrical tape. Keep them away from any electrical or metal parts.
4. Reinstall the cover of the electric control box.

Step 4:

1. Remove the wire cover from the unit by loosening the 3 screws.
2. Remove caps on the conduit panel.
3. Mount the conduit tubes (not included) on the conduit panel.
4. Properly connect both the power supply and low voltage lines to the corresponding terminals on the terminal block.
5. Ground the unit in accordance with local switches.
6. Be sure to size each wire allowing several inches longer than the required length for wiring.

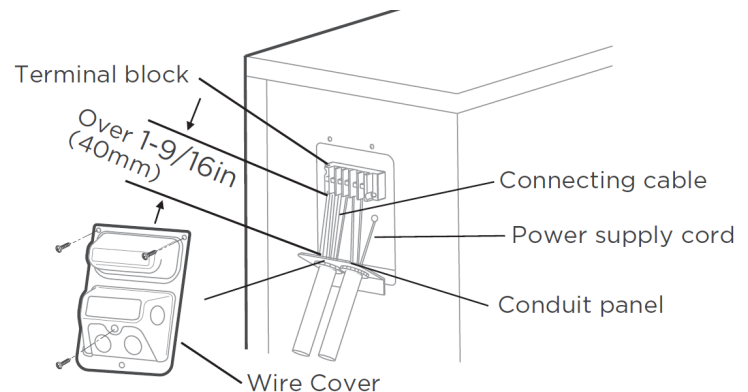

Please select the appropriate through-hole according to the diameter of the wire.

8.4 Indoor Unit Wiring

! WARNING

ISOLATE THE POWER SUPPLY LEADS AND COMMUNICATION LEADS BY THE STRAIN RELIEF AND KEEP POWER SUPPLY LEADS AWAY FROM COMMUNICATION LEADS.

Step 1: Prepare the cable for connection.

- Using wire strippers, strip the rubber jacket from both ends of the signal cable to reveal about 5.9in (15cm) of the wire.
- Strip the insulation from the ends of the wires.

Step 2: Open the front panel.

Open the front panel of the indoor unit. Using a screwdriver, remove the cover of the electric control box on your indoor unit.

Step 3: Connect the wires to the terminals.

- Thread the power cable and the signal cable through the wire outlet.
- Match the wire colors/labels with the labels on the terminal block. Firmly screw the wires of each wire to its corresponding terminal. Refer to the Serial Number and Wiring Diagram located on the cover of the electric control box. Terminal block wiring: when using 208V or 230V, connect L1 and L2. When using 115V, connect L1 and L2.

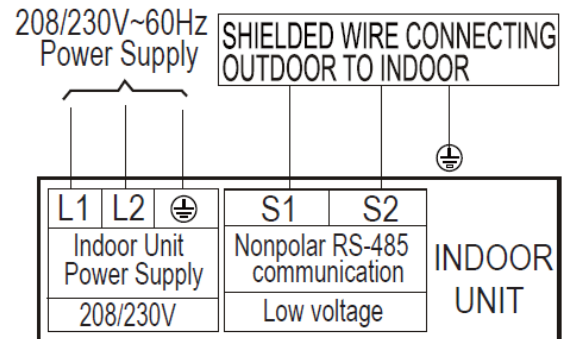
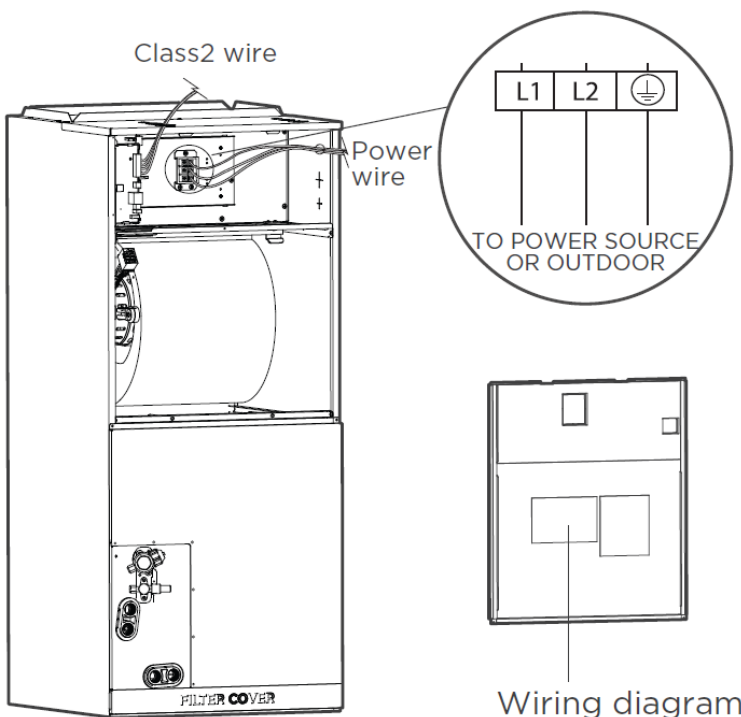

- Clamp down the cable with the cable clamp. The cable must not be loose or pull on the u-lugs.
- Reattach the electric box cover.

! CAUTION

- While connecting the wires, strictly follow the wiring diagram.
- The refrigerant circuit can become very hot. Keep the interconnection cable away from the copper tube.
- The holes on the cover of the electronic control box must be threaded through with armored wires.

115V Power Supply Installation Guide

Step 1:

Open the front cover.

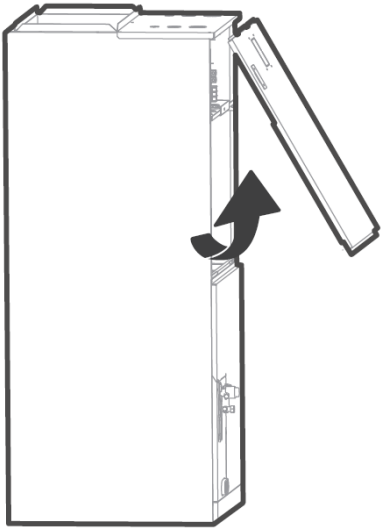

Step 2:

When using 115V power supply, the fan motor wiring requires the use of a 115V fan motor pair plug. At this time, the white fan motor pair plug needs to be removed and the red fan motor pair plug needs to be connected.

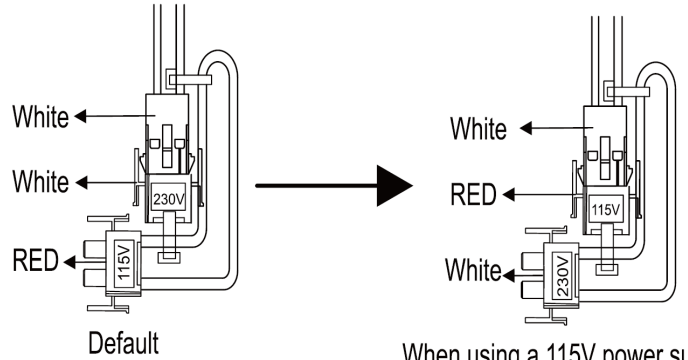

When using a 115V power supply, the motor is plugged in red.

Step 3:

Unplug temperature sensors T1, T2, T2A, T2B, refrigerant detection sensor and electronic expansion valve (EEV), and fan motor power pair plug (CN11) from the control board.

- **T1:** IDU Room Temperature Sensor (T1)
- **T2:** IDU Coil Temperature Sensor (T2)
- **T2A:** Evaporator Coil Temperature Sensor
- **T2B:** Evaporator Coil Inlet Temperature Sensor (T2B)

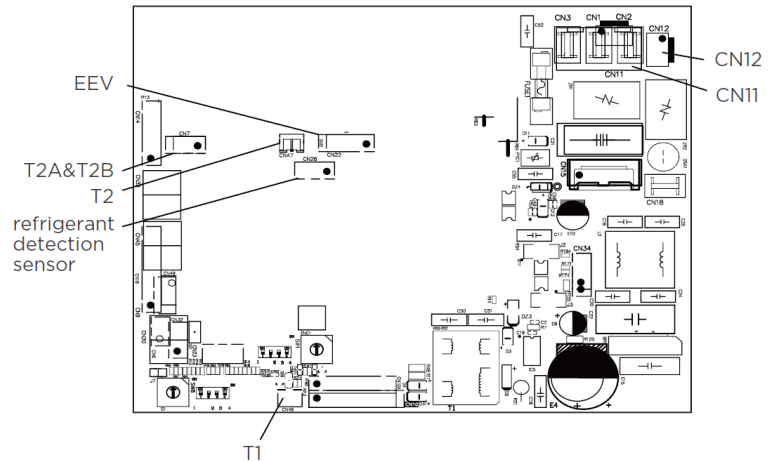
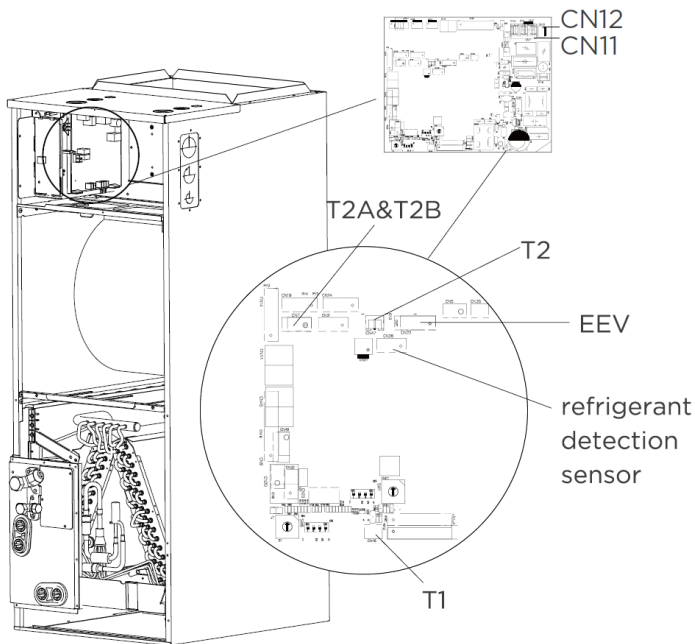

8 ELECTRICAL CONNECTIONS

Step 4:

Remove the two screws in the electric cabinet, and take out the electric cabinet.

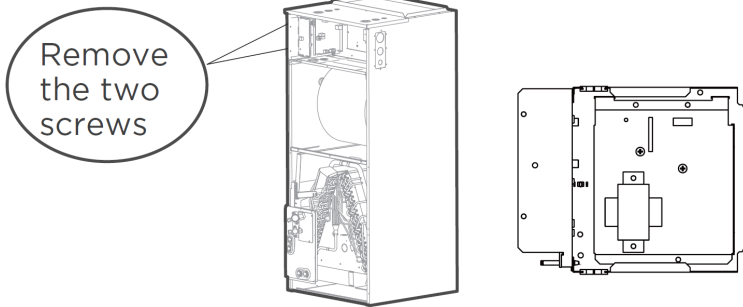

Step 5:

Remove the blue connector from control board CN12.

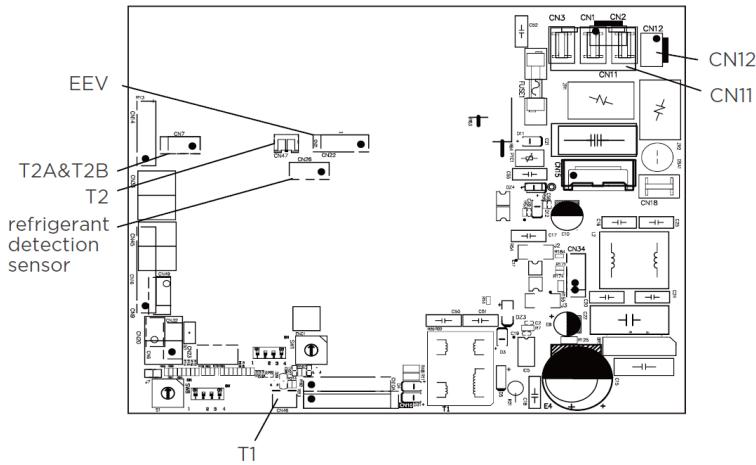

Step 6:

Remove the red connector from the 24V transformer.

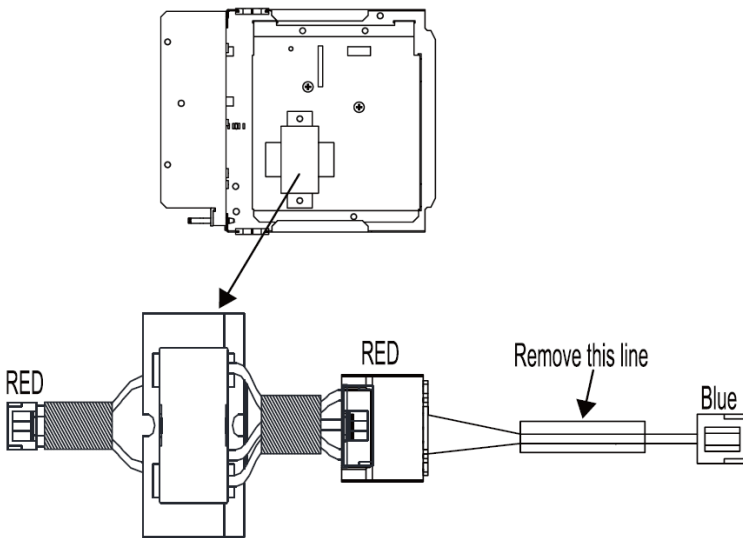

Step 7:

Take the 24V transformer connection wire out from the accessory package. Connect the red connector to the 24V transformer and the blue connector to the control board CN12.

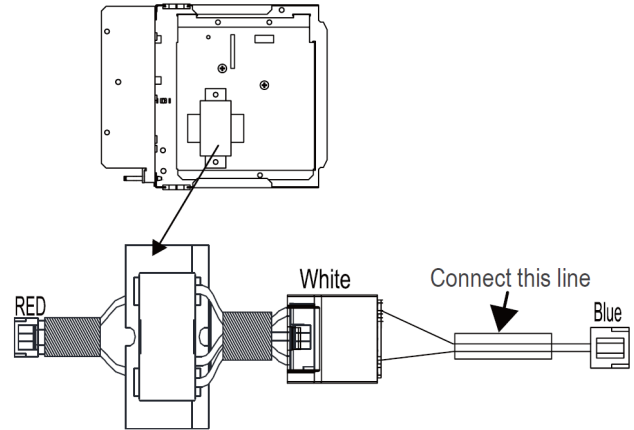

Step 8:

Replace the electronic control box with the entire machine, fix it with screws, and insert the wire body properly. Plug temperature sensors T1, T2, T2A, T2B refrigerant detection sensor, and electronic expansion valve (EEV), and fan motor power pair plug (CN11) from the control board.

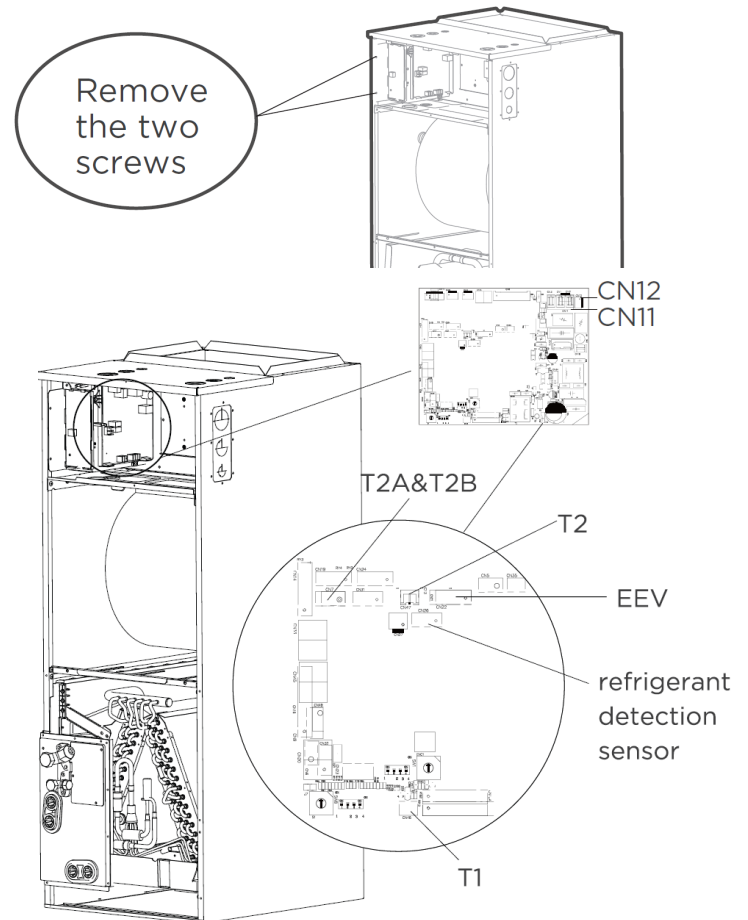

8.5 Specific Wiring Methods



Refer to the wiring nameplate for the wiring method. Do not connect the power cord to the communication line, as this may damage the system.

The following wiring diagrams are suitable with a 24V thermostat.

• Wiring for 4H and 2C thermostat

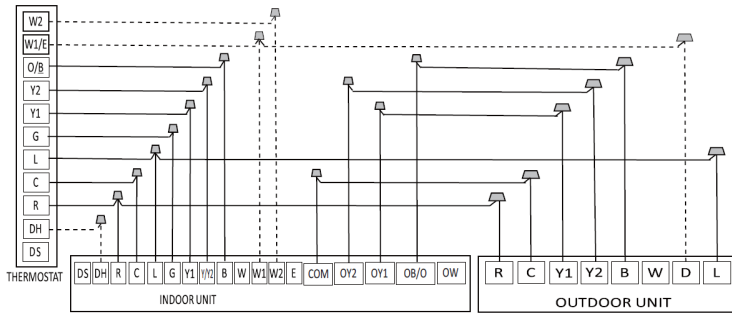

S4-2 Default on, DH function off. Turn switch off to activate DH function.

S4-4 Default on, W1 and W2 shorted for single stage Aux heat operation. Turn off to separate stages.

• Wiring for 3H and 2C thermostat

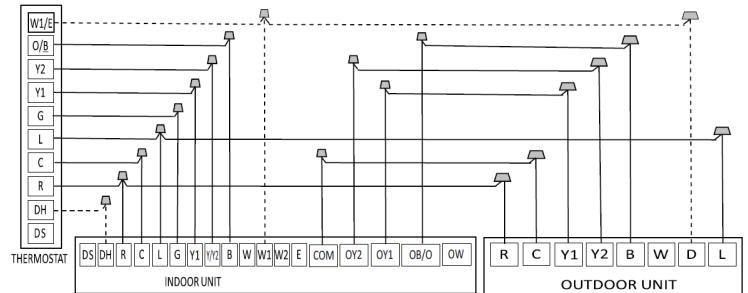

S4-2 Default on, DH function off. Turn switch off to activate DH function.

S4-4 Default on, W1 and W2 shorted for single stage Aux heat operation. Turn off to separate stages.

• Wiring for 3H and 1C thermostat

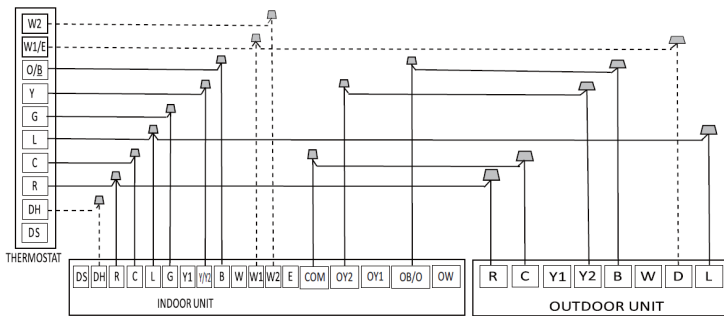

S4-2 Default on, DH function off. Turn switch off to activate DH function.

S4-4 Default on, W1 and W2 shorted for single stage Aux heat operation. Turn off to separate stages.

• Wiring for 2H and 2C thermostat

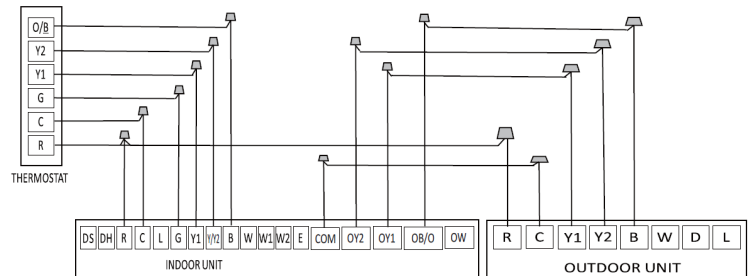

• Wiring for 3H and 2C thermostat

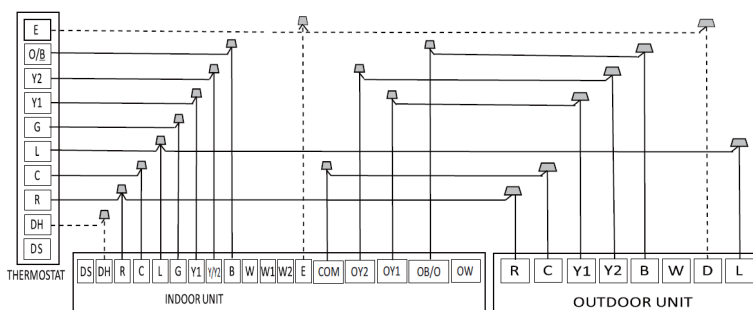

S4-2 Default on, DH function off. Turn switch off to activate DH function.

Emergency heating control two groups of electric heating at the same time

• Wiring for 2H and 1C thermostat

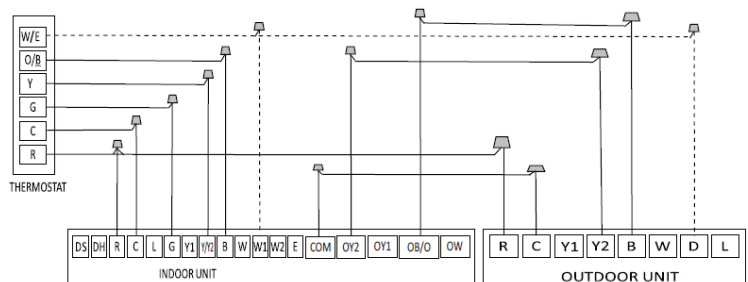

S4-4 Default on, W1 and W2 shorted for single stage Aux heat operation. Turn off to separate stages.

8 ELECTRICAL CONNECTIONS

• Wiring for 1H and 1C thermostat

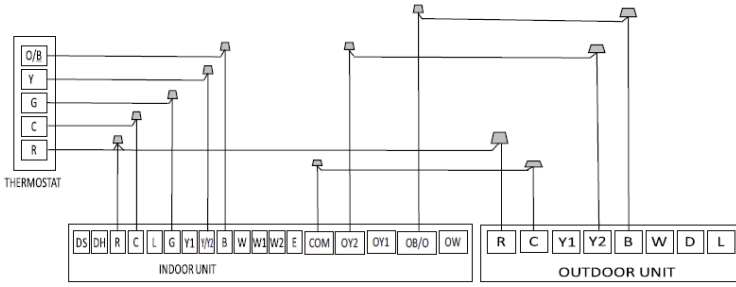

• Wiring for 1H and 1C thermostat

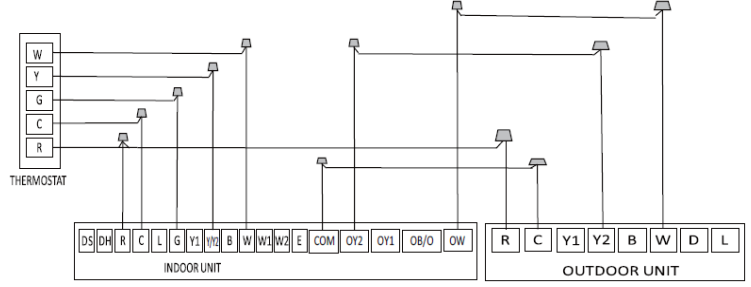

Optional Function Wiring:

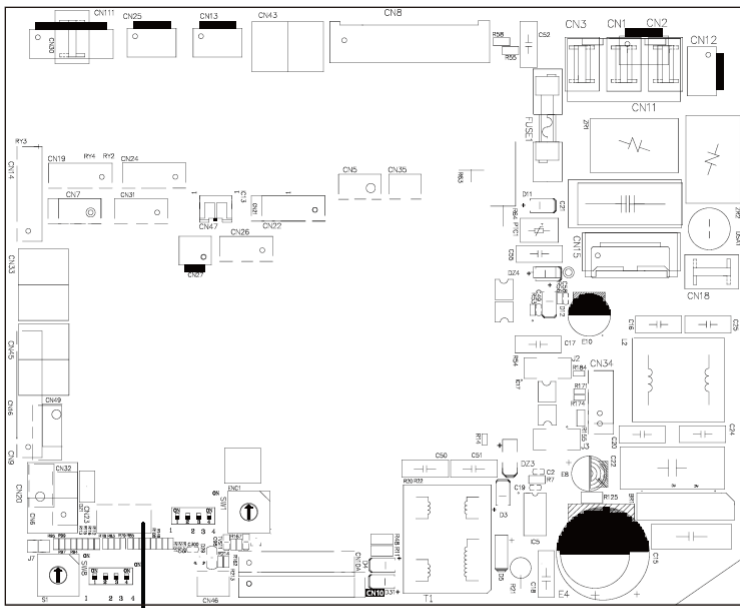

Condensate
Overflow
Switch
Interface

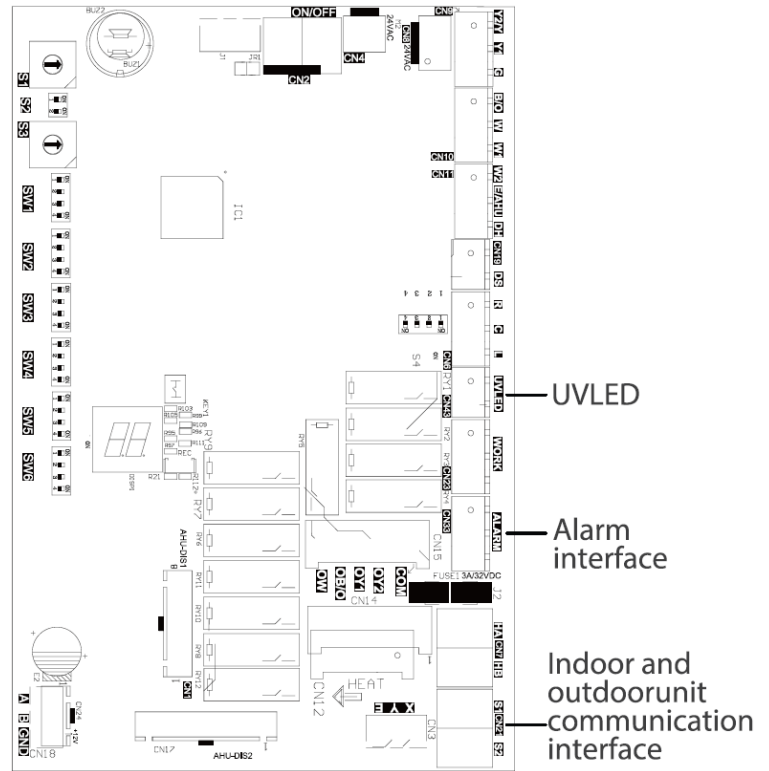

Condensate Overflow Switch:

The unit will accommodate a remote condensate overflow switch. To enable, remove jumper J7 and connect the installer-provided condensate overflow device to CN23 per below. When an overflow condition is present, the device should open connection signaling the unit to turn off the system.

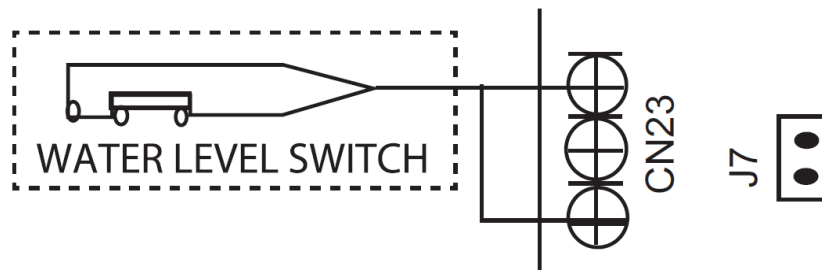

Fault Warning:

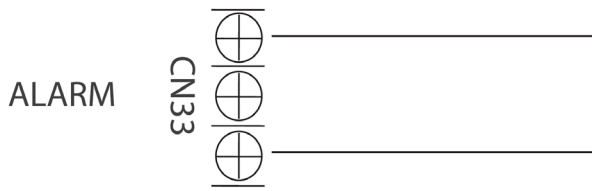

Alarm Output:

An alarm output (CN33) can be utilized if actions are required when a fault is present. This is a passive outlet port, so you will need to input a voltage signal. The relay is normally open for normal operation, and closed when a fault condition is active.

Humidifier Control:

To connect a humidifier, utilize the passive signal "WORK" output (CN23) port as well as the R and C wires on the controller, and wire the humidistat and humidifier per above wiring diagram. When the fan is running, the CN23 relay will be closed, which will allow power to the humidifier when the humidistat is below the humidity set point. If the thermostat or zone controller has an HUM interface, connect the humidifier directly to the HUM and C ports.

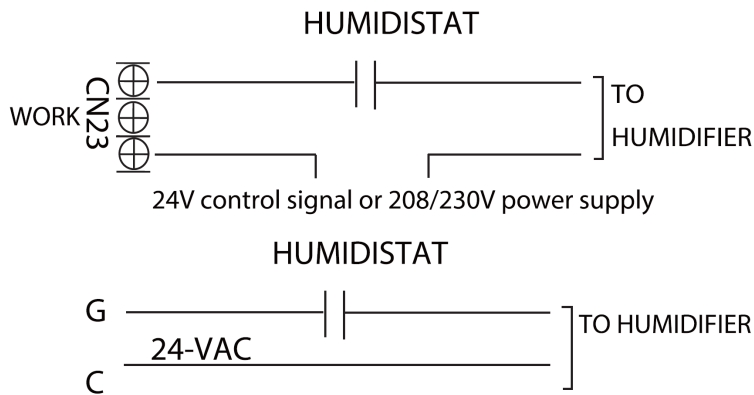

UV, Fresh Air, or Ion Generator Wiring

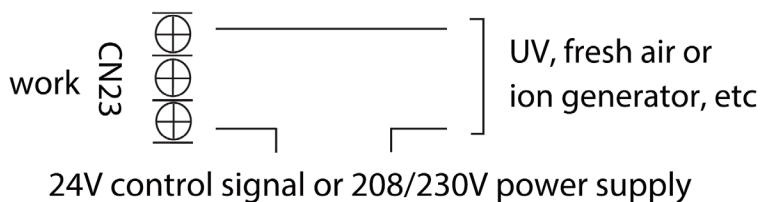

The WORK port is linked with the fan. When the fan is running, the relay is closed

Control Logic

Indoor Unit Connector

Connector	Purpose
R	24V Power Connection
C	Common
G	Fan Control
Y1	Low Cooling
Y/Y2	High Cooling
B	Heating Reversing Valve
W	Heating Control
W1	Stage 1 Electric Heating
W2	Stage 2 Electric Heating
E/AUX	Emergency Heating
DH/BK	Dehumidification/Zoning Control
DS	Reserved Signal
L	System Fault Signal

Outdoor Unit Connector

Connector	Purpose
R	24V Power Connection
C	Common
Y1	Low Demand
Y2	High Demand
B	Heating Reversing Valve
W	Heating Control
D	Defrost Control
L	System Fault Signal

LED Display

The control displays unit status as well as any active fault codes on the LED display. If the unit is functioning normally, the LED will display the current temperature set point. When a fault code is active, the display will quickly flash the active fault code. Refer to the fault code table located in the troubleshooting section of the manual for detailed fault code information.

Function DIP Switch Settings:

The 24V thermostat modes must refer to the following settings:

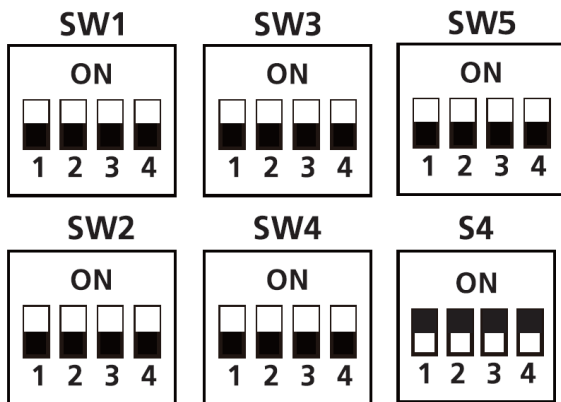

SW4-1	000 is the default 000/001/010/011/100 /101/110/111, internal machines with different abilities, electric heating, and PSC classification for use.
SW4-2	
SW4-3	

Function Combination Table of SW1-1 and SW1-4:

SW1	Control Type	IDU and ODU Connection	Note
	24V Thermostat	S1+S2	Scenario 1
	24V Thermostat	24V Connection	Scenario 3

Indoor Unit Dial Code

No.	Dial Code	Control Scenario	Function	ON	OFF	Note
1	SW1-2	1, 2, 3	Anti-cold blow protection option	NO	[Default] YES	
2	SW1-3	1, 2, 3	Single cooling/heating and cooling options	Cooling	[Default] Cooling & Heating	
3	SW2-1	1	Compressor Running (demand working with heat pump+electric heat)	Compressor slower speed	[Default] Faster Compressor	
4	SW2-1	2	Temperature differential to activate first stage auxiliary heat (the GAP of T1 and Ts), Wire controller demand with heat pump+electric heat working together	2°F (1°C)	[Default] 4°F (2°C)	Only affects compressor and W1
5	SW2-2	2	Electric heat on delay	YES	[Default] NO	
6	SW2-3	2	Electric auxiliary heating delay to start time	30 minutes	[Default] 15 minutes	Based on SW2-2 is ON.
7	SW2-4	1	Compressor	<p>The operation of the heat pump is limited by the outdoor temperature, and the operation of auxiliary heat is not limited. The system makes judgments according to the following rules:</p> <p>1) The compressor can be operated when the outdoor temperature is \geqS3 DIP switch temperature +35.6°F (2°C).</p> <p>2) The compressor cannot be operated when the outdoor temperature is lower than the S3 DIP switch temperature.</p>	<p>[Default] The operation of heat pump is limited by the outdoor temperature, and the operation of auxiliary heat is not limited. The system makes judgments based on the following rules:</p> <p>1) The compressor cannot be operated when the outdoor temperature is lower than the S3 DIP switch,</p> <p>2) The c compressor can be operated when the outdoor temperature is \geqS3 DIP switch temperature +35.6°F (2°C).</p>	SW2-4 and S3 need to be working together.
8	SW2-4	2	Compressor/Auxiliary heat outdoor ambient lockout	<p>The operation of heat pump is limited by the outdoor temperature, and the operation of auxiliary heat is not limited. The system makes judgments according to the following rules:</p> <p>1) The compressor can be operated when the outdoor temperature is \geqS3 DIP switch temperature +35.6°F (2°C).</p> <p>2) The compressor cannot be operated when the outdoor temperature is lower than the S3 DIP switch temperature.</p>	<p>[Default] Only one heat pump or auxiliary heat can be operated. The system makes judgment according to the following rules:</p> <p>1) When the outdoor temperature is lower than the S3 DIP switch temperature, the compressor is not allowed to operate, but auxiliary heat is allowed to operate.</p> <p>2) When the outdoor temperature is \geqS3 DIP switch temperature +35.6°F (2°C), the compressor can be operated but auxiliary heat cannot be operated.</p>	SW2-4 and S3 need to be working together.

8 ELECTRICAL CONNECTIONS

No.	Dial Code	Control Scenario	Function	ON	OFF	Note
9	Rotary Switch S3	1, 2	Set outdoor temperature limitation (for auxiliary heating or compressor)	Table A		
10	SW3-1	1	Maximum continuous runtime allowed before system automatically stages up capacity to satisfy set point. This adds 1 to 5°F to the user set point to increase capacity and satisfy user set point.	30 minutes	[Default] 90 minutes	
11	SW3-2	1	Cooling and heating Y/Y2 temperature differential adjustment	Compressor slower speed	[Default] Faster compressor	Only affects compressor
12	SW3-3	1	Compressor running (demand working with heat pump+electric heat)	Compressor slower speed	[Default] Faster compressor	Only affects compressor and W2
13	SW3-3	2	Temperature differential to activate second stage auxiliary heating (the GAP of T1 and Ts). Wire controller demand with heat pump+electric heat working together	4°F (2°C)	[Default] 6°F (3°C)	
14	SW3-4	1, 3	Fan speed of cooling mode when 24V Thermostat is applied for	Turbo	High	
15	SW4-1 SW4-2 SW4-3	1, 2, 3	Electric heat nominal CFM adjustment	Available settings are 000/001/010/011. Each digit corresponds to an individual switch position. For example [SW4-1 OFF, SW4-2 ON, SW4-3 OFF] = 010; See table 11 for the corresponding CFM adjustment.		
16	SW4-4	2	Temperature differential to activate third stage auxiliary heating (the GAP of T1 and Ts) Wire controller demand with heat pump + electric heat working together	6°F (3°C)	[Default] 8° (4°C)	Only valid for product which has three stage auxiliary heating.
17	SW4-4	1,3	Default ON	[Default] For single stage supplemental heat, W1 and W2 are connected	For dual stage supplemental heat, W1 and W2 are controlled independently	
18	S4-2	1,3	DH Function Selection	[Default] Dehumidification control not available	Dehumidification feature is enabled through thermostat	
19	SW5-3	1,2,3	L or Alarm relay selection	L output 24V or alarm relay close only when refrigerant sensor fault or R454B refrigerant leakage is detected	[Default] L output 24V or alarm relay closed when any fault is detected	
20	SW5-4	1,2,3	R output selection	R stop output 24V when refrigerant sensor fault or R454B refrigerant leakage is detected	[Default] R keep output 24V even when refrigerant sensor fault or R454B refrigerant leakage is detected	

Control Scenario	24V Tstat, S1+S2	1
	Wired Controller S1+S2	2
	Full 24V	3

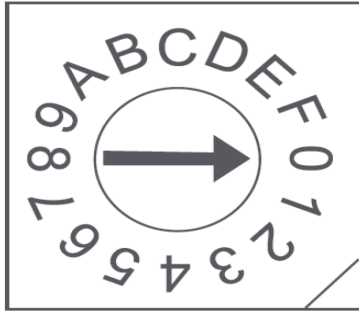

Address DIP Switch:

Address dialing S1+SW8: When the user uses the centralized controller, the address dialing is required.

Network address: The address silkscreen is NET address, which is composed of a 16-bit address rotary code S1 plus a two-digit DIP switch SW8 [Set during engineering installation, network function does not need to be set]

When SW8 is 00 (the dialing code is not connected), the network address value is the value of S1;

When SW8 is 10 (corresponding to the switch of the hardware connected to the 10K resistor), the network address value is S1 plus 16;

Determined by dial code SW8 1-10K 2-5.1K.

When SW8 is 01 (corresponding to the dial code of the 5.1K resistor connected to the hardware is turned on), the network address value is the value of S1 plus 32;

When SW8 is 11 (all dialing codes are on), the network address value is the value of S1 plus 48.

Outdoor Unit DIP Switch Setting:

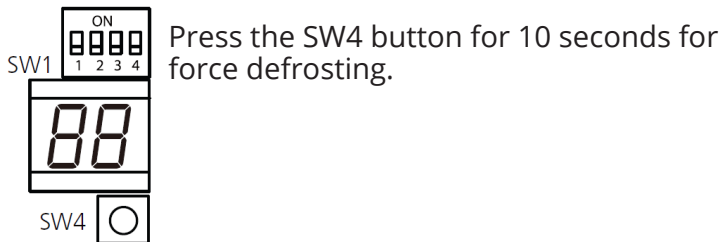

No.	Dial Code	Features	ON	OFF
1	SW1-1	Function to be defined		
2	SW1-2	Communication dial code	24V communication only	24V communication/ 485 communication
3	SW1-3	Strong cold and strong heat function	The cooling/heating target pressure compensation value is valid	The cooling/heating target pressure compensation value is invalid
4	SW1-4	Enhanced defrosting function	Enhanced defrosting	Default setting (standard defrost algorithm)

Table A

S3	S3 (°F)	S3 (°C)
0	OFF	OFF
1	-22	-30
2	-18	-28
3	-15	-26
4	-11	-24
5	-8	-22
6	-4	-20
7	3	-16
8	10	-12
9	18	-8
A	25	-4
B	32	0
C	36	2
D	39	4
E	43	6
F	46	8

Determined by dial code SW8 1-10K 2-5.1K

Dial code selection	Website address
	S1 + 48
	S1 + 32
	S1 + 16
	S1

Air Volume Table

Capacity	External Static Pressure Range	Fan Speed	Electric Auxiliary Heat Module	24V Thermostat		Airflow Volume (CFM)
				DIP Switch	24V Terminal Engaged	
18K (1.5 Ton)	0-0.80 in. wc.	Cooling Turbo	-	SW3-4 = ON	Y2/Y	618
		Cooling High	-	SW3-4 = OFF	Y2/Y	576
		Cooling Medium	-	-	Y1	529
		Cooling Low	-	-	-	488
		Heat Pump Turbo	-	-	-	565
		Heat Pump High	-	-	B + Y2/Y, W	541
		Heat Pump Medium	-	-	Y1	435
		Heat Pump Low	-	-	-	400
		Electric Auxiliary Heat Module 0	10kW	SW4-1 = OFF SW4-2 = OFF SW4-3 = OFF	W1, W2, AUX	653
		Electric Auxiliary Heat Module 1	10kW, 8kW	SW4-1 = OFF SW4-2 = OFF SW4-3 = ON	W1, W2, AUX	624
		Electric Auxiliary Heat Module 2	8kW	SW4-1 = OFF SW4-2 = ON SW4-3 = OFF	W1, W2, AUX	594
		Electric Auxiliary Heat Module 3	5kW, 3kW	SW4-1 = OFF SW4-2 = ON SW4-3 = ON	W1, W2, AUX	565
24K (2 Ton)	0-0.80 in. wc.	Cooling Turbo	-	SW3-4 = ON	Y2/Y	84
		Cooling High	-	SW3-4 = OFF	Y2/Y	759
		Cooling Medium	-	-	Y1	694
		Cooling Low	-	-	-	629
		Heat Pump Turbo	-	-	-	788
		Heat Pump High	-	-	B + Y2/Y, W	753
		Heat Pump Medium	-	-	Y1	641
		Heat Pump Low	-	-	-	524
		Electric Auxiliary Module 0	15kW	SW4-1 = OFF SW4-2 = OFF SW4-3 = OFF	W1, W2, AUX	871
		Electric Auxiliary Module 1	15kW, 10kW	SW4-1 = OFF SW4-2 = OFF SW4-3 = ON	W1, W2, AUX	841
		Electric Auxiliary Module 2	10kW, 8kW	SW4-1 = OFF SW4-2 = ON SW4-3 = OFF	W1, W2, AUX	818
		Electric Auxiliary Module 3	5kW	SW4-1 = OFF SW4-2 = ON SW4-3 = ON	W1, W2, AUX	788
36K (2.5 Ton)	0-0.80 in. wc.	Cooling Turbo	-	SW3-4 = ON	Y2/Y	988
		Cooling High	-	SW3-4 = OFF	Y2/Y	894
		Cooling Medium	-	-	Y1	806
		Cooling Low	-	-	-	712
		Heat Pump Turbo	-	-	-	918
		Heat Pump High	-	-	B + Y2/Y, W	876
		Heat Pump Medium	-	-	Y1	665
		Heat Pump Low	-	-	-	453
		Electric Auxiliary Module 0	15kW	SW4-1 = OFF SW4-2 = OFF SW4-3 = OFF	W1, W2, AUX	1088
		Electric Auxiliary Module 1	15kW, 10kW	SW4-1 = OFF SW4-2 = OFF SW4-3 = ON	W1, W2, AUX	1029
		Electric Auxiliary Module 2	10kW, 8kW	SW4-1 = OFF SW4-2 = ON SW4-3 = OFF	W1, W2, AUX	976
		Electric Auxiliary Module 3	5kW	SW4-1 = OFF SW4-2 = ON SW4-3 = ON	W1, W2, AUX	918

8 ELECTRICAL CONNECTIONS

Air Volume Table

The constant airflow volume motor is applied. Therefore, the airflow volume is constant at all ESP within the stated range.

Capacity	External Static Pressure Range	Fan Speed	Electric Auxiliary Heat Module	24V Thermostat		Airflow Volume (CFM)
				DIP Switch	24V Terminal Engaged	
36K (3 Ton)	0-0.80 in. wc.	Cooling Turbo	-	SW3-4 = ON	Y2/Y	1188
		Cooling High	-	SW3-4 = OFF	Y2/Y	1082
		Cooling Medium	-	-	Y1	971
		Cooling Low	-	-	-	865
		Heat Pump Turbo	-	-	-	1112
		Heat Pump High	-	-	B + Y2/Y, W	1059
		Heat Pump Medium	-	-	Y1	794
		Heat Pump Low	-	-	-	582
		Electric Auxiliary Heat Module 0	20kW	SW4-1 = OFF SW4-2 = OFF SW4-3 = OFF	W1, W2, AUX	1306
		Electric Auxiliary Heat Module 1	15kW	SW4-1 = OFF SW4-2 = OFF SW4-3 = ON	W1, W2, AUX	1241
		Electric Auxiliary Heat Module 2	10kW, 8kW	SW4-1 = OFF SW4-2 = ON SW4-3 = OFF	W1, W2, AUX	1176
		Electric Auxiliary Heat Module 3	5kW, 8kW	SW4-1 = OFF SW4-2 = ON SW4-3 = ON	W1, W2, AUX	1112
48K (4 Ton)	0-0.80 in. wc.	Cooling Turbo	-	SW3-4 = ON	Y2/Y	1600
		Cooling High	-	SW3-4 = OFF	Y2/Y	1471
		Cooling Medium	-	-	Y1	1282
		Cooling Low	-	-	-	1094
		Heat Pump Turbo	-	-	-	1471
		Heat Pump High	-	-	B + Y2/Y, W	1324
		Heat Pump Medium	-	-	Y1	1141
		Heat Pump Low	-	-	-	976
		Electric Auxiliary Module 0	20kW	SW4-1 = OFF SW4-2 = OFF SW4-3 = OFF	W1, W2, AUX	1741
		Electric Auxiliary Module 1	15kW	SW4-1 = OFF SW4-2 = OFF SW4-3 = ON	W1, W2, AUX	1653
		Electric Auxiliary Module 2	10kW, 8kW	SW4-1 = OFF SW4-2 = ON SW4-3 = OFF	W1, W2, AUX	1559
		Electric Auxiliary Module 3	8kW	SW4-1 = OFF SW4-2 = ON SW4-3 = ON	W1, W2, AUX	1471
60K (5 Ton)	0-0.80 in. wc.	Cooling Turbo	-	SW3-4 = ON	Y2/Y	1806
		Cooling High	-	SW3-4 = OFF	Y2/Y	1582
		Cooling Medium	-	-	Y1	1359
		Cooling Low	-	-	-	1135
		Heat Pump Turbo	-	-	-	1659
		Heat Pump High	-	-	B + Y2/Y, W	1582
		Heat Pump Medium	-	-	Y1	1247
		Heat Pump Low	-	-	-	976
		Electric Auxiliary Module 0	25kW	SW4-1 = OFF SW4-2 = OFF SW4-3 = OFF	W1, W2, AUX	2171
		Electric Auxiliary Module 1	15kW, 20kW	SW4-1 = OFF SW4-2 = OFF SW4-3 = ON	W1, W2, AUX	2029
		Electric Auxiliary Module 2	10kW, 15kW	SW4-1 = OFF SW4-2 = ON SW4-3 = OFF	W1, W2, AUX	1894
		Electric Auxiliary Module 3	10kW	SW4-1 = OFF SW4-2 = ON SW4-3 = ON	W1, W2, AUX	1753

9-Specifications

VersaPro®		18K	24K	30K
Power	Phase	1 Phase		
	Frequency & Volt	208/230V, 60Hz		
Outdoor Unit	MCA	16A	19A	22.5A
	MOP	20A	20A	25A
Line Gauge	Outdoor Unit Power Line	Line Quantity	2+Ground	
		Line Diameter (AWG)	14	12
	Outdoor-Indoor Signal Line	Line Quantity	2	
		Line Diameter (AWG)	20	
	Thermostat Signal Line	Line Quantity	---	
		Line Diameter (AWG)	18	

VersaPro®		36K	48K	60K
Power	Phase	1 Phase		
	Frequency & Volt	208/230V, 60Hz		
Outdoor Unit	MCA	24A	36A	39A
	MOP	30A	40A	40A
Line Gauge	Outdoor Unit Power Line	Line Quantity	2+Ground	
		Line Diameter (AWG)	10	8
	Outdoor-Indoor Signal Line	Line Quantity	2	
		Line Diameter (AWG)	20	
	Thermostat Signal Line	Line Quantity	---	
		Line Diameter (AWG)	18	

Hyper Heat		24K	30K	36K
Power	Phase	1 Phase		
	Frequency & Volt	208/230V, 60Hz		
Outdoor Unit	MCA	19A	/	29A
	MOP	20A	/	30A
Line Gauge	Outdoor Unit Power Line	Line Quantity	2+Ground	
		Line Diameter (AWG)	12	10
	Outdoor-Indoor Signal Line	Line Quantity	2	
		Line Diameter (AWG)	20	
	Thermostat Signal Line	Line Quantity	---	
		Line Diameter (AWG)	18	

Hyper Heat		48K	60K	
Power	Phase	1 Phase		
	Frequency & Volt	208/230V, 60Hz		
Outdoor Unit	MCA	38A	40A	
	MOP	40A	40A	
Line Gauge	Outdoor Unit Power Line	Line Quantity	2+Ground	
		Line Diameter (AWG)	8	8
	Outdoor-Indoor Signal Line	Line Quantity	2	
		Line Diameter (AWG)	20	
	Thermostat Signal Line	Line Quantity	---	
		Line Diameter (AWG)	18	

NOTE

Line Diameter Sizing per NFPA 70 (2020), Table 310.5 (B) (16) Based on type NM-B Romex wire. Other sizing options are possible. Consult NFPA 70 or a licensed electrician for alternate sizing.

10 AIR EVACUATION

10.1 Air Evacuation Preparation & Precautions

Air and foreign matter in the refrigerant circuit can cause abnormal rises in pressure, which can damage the unit, reduce its efficiency, and cause injury. Use a vacuum pump and manifold gauge to evacuate the refrigerant circuit, removing any non-condensable gas and moisture from the system. Evacuation should be performed upon initial installation and when unit is relocated.

NOTICE

When opening valve stems, turn the hexagonal wrench until it hits against the stopper. Do not try to force the valve open further.

Before Performing Evacuation:

- ☑ Check to ensure the connective pipes between the indoor and outdoor units are connected properly.
- ☑ Check to make sure all wiring is connected properly.

10.2 Evacuation Instructions

1. Connect the charge hose of the manifold gauge to service port on the outdoor unit's low pressure valve.
2. Connect another charge hose from the manifold gauge to the vacuum pump.
3. Open the low pressure side of the manifold gauge. Keep the high pressure side closed.
4. Turn on the vacuum pump to evacuate the system.
5. Run the vacuum for at least 15 minutes, or until the compound meter reads -750 Microns (-10^5 Pa).
6. Close the low pressure side of the manifold gauge, and turn off the vacuum pump.
7. Wait for 5 minutes, then check that there has been no change in system pressure.
8. If there is a change in system pressure, refer to the Gas Leak Check section for information on how to check for leaks. If there is no change in system pressure, unscrew the cap from the packed valve (high pressure valve).
9. Insert hexagonal wrench into the packed valve (high pressure valve) and open the valve by turning the wrench in a 1/4 counter clockwise turn. Listen for gas to exit the system, then close the valve after 5 seconds.
10. Watch the pressure gauge for one minute to make sure that there is no change in pressure. The pressure gauge should read slightly higher than atmospheric pressure.
11. Remove the charge hose from the service port.

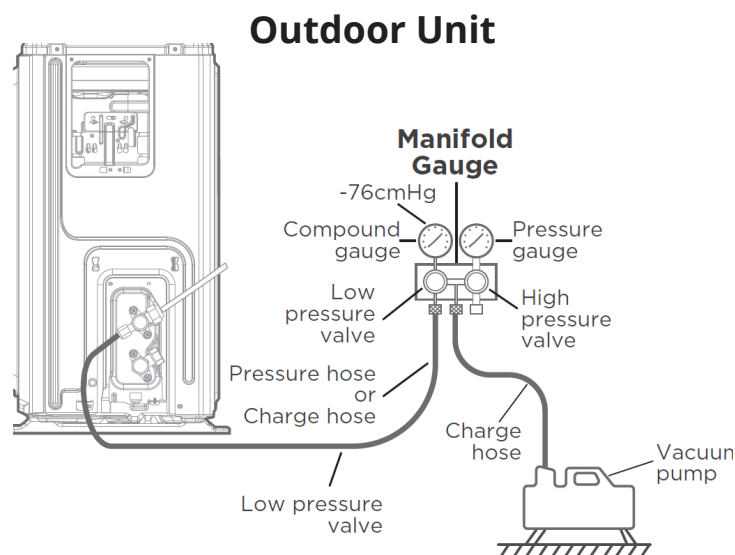

11 ADDING REFRIGERANT

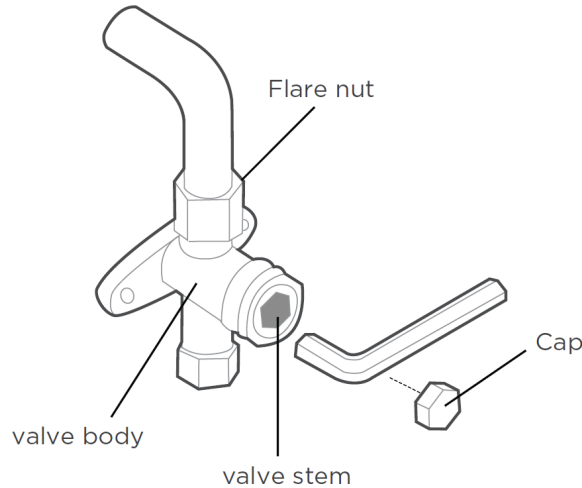

12. Connect the charge hose of the manifold gauge to service port on the outdoor unit's high pressure valve. Repeat steps 2 to 11 above.
13. Using a hexagonal wrench, fully open both high pressure and low pressure valves. (Included inside unit.)
14. Tighten valve caps on all four valves (1-high pressure, 1-low pressure, 2-service port) by hand. You may tighten it further using a torque wrench if needed.

11-Adding Refrigerant

! CAUTION

DO NOT mix refrigerant types.

Some systems require additional charging depending on pipe lengths. The standard pipe length varies according to local regulations. For example, in North America, the standard pipe length is 25ft (7.5m). In other areas, the standard pipe length is 25 ft (7m). The refrigerant should be charged from the service port on the outdoor unit's low pressure valve. The additional refrigerant to be charged can be calculated using the following formula:

Refrigerant	Liquid Side Diameter	
	Φ1/4in (Φ6.35mm)	Φ 3/8in (Φ9.52mm)
R454B: (Orifice tube in the indoor unit)	Total pipe length - standard pipe length x 30g (0.32oz)/m(ft)	Total pipe length - standard pipe length x 65g (0.7oz)/m(ft)

CAUTION

Failure to perform the test run may result in unit damage, property damage, or personal injury.

12.1 Before Test Run

A test run must be performed after the entire system has been completely installed. Confirm the following points before performing the test:

- a) Indoor and outdoor units are properly installed.
- b) Piping and wiring are properly connected.
- c) No obstacles near the inlet and outlet of the unit that might cause poor performance or product malfunction.
- d) Refrigeration system does not leak.
- e) Drainage system is unimpeded and draining to a safe location.
- f) Insulation of piping and duct is properly installed.
- g) Grounding wires are properly connected.
- h) Length of the piping and additional refrigerant capacity have been recorded.
- i) Power voltage is the correct voltage for the system.

12.2 Test Run Instructions

1. Open both the liquid and gas service valves.
2. Turn on the main power switch and allow the unit to warm up.
3. Set the unit to COOL mode.
4. For the Indoor Unit
 - a. Double check to see if the room temperature is being registered correctly.
 - b. Ensure the manual buttons on the indoor unit work properly.
 - c. Check to see that the drainage system is unimpeded and draining smoothly.
 - d. Ensure there is no vibration or abnormal noise during operation.
5. For the Outdoor Unit
 - a. Check for any leaks from the refrigeration system.
 - b. Make sure there is no vibration or abnormal noise during operation.
 - c. Ensure the wind, noise, and water generated by the unit do not disturb individuals nearby or pose a safety hazard.
6. Drainage Test
 - a. Ensure the drainpipe flows smoothly. New buildings should perform this test before finishing the ceiling.
 - b. Turn on the main power switch and run the unit in COOL mode.
 - c. Check to see that the water is discharged. It may take up to one minute before the unit begins to drain depending on the drainpipe.
 - d. Make sure that there are no leaks in any of the piping.
 - e. Stop the unit. Turn off the main power switch and reinstall the test cover.

NOTICE

If the unit malfunctions or does not operate according to expectations, refer to the Troubleshooting section of the Service Manual before calling customer service.

12.3 24V Signal Chart

Mode	Priority	G	Y1	Y/Y2	B	W	W1	W2	E/AUX	DH	Fan Speed	Display
OFF	/	0	0	0	0	0	0	0	0	*	OFF	00
FAN	7	1	0	0	*	0	0	0	0	*	Low	01
Cooling Stage 1	6	*	1	0	0	0	0	0	0	1	Mid	02
Cooling Stage 2		*	*	1	0	0	0	0	0	1	High	03
Dehumidification 1		*	1	0	0	0	0	0	0	0	Low	04
Dehumidification 2		*	*	1	0	0	0	0	0	0	Low	05
Heat Pump Stage 1	5	*	1	0	1	0	0	A	0	1	Mid	06
Heat Pump Stage 2		*	*	1	1	0	0	A	0	1	High	
Heat Pump Stage 2		*	*	*	*	1	0	A	0	1	High	07
Electric Auxiliary Heat Module 1	3	*	0	0	*	0	1	A	0	*	Turbo	08
Electric Auxiliary Heat Module 2		*	0	0	*	0	0	1	0	*	Turbo	
Electric Auxiliary Heat Module 1 & 2		*	0	0	*	0	1	1	0	*	Turbo	09
Heat Pump Stage 1 + Electric Auxiliary Heat Module 1	1	*	1	0	1	0	1	0	0	1	Turbo	10
Heat Pump Stage 1 + Electric Auxiliary Heat Module 2		*	*	0	1	0	0	1	0	1	Turbo	
Heat Pump Stage 2 + Electric Auxiliary Heat Module 1		*	*	1	1	0	1	0	0	1	Turbo	
Heat Pump Stage 2 + Electric Auxiliary Heat Module 1		*	*	*	*	1	1	0	0	1	Turbo	
Heat Pump Stage 2 + Electric Auxiliary Heat Module 2		*	*	1	1	0	0	1	0	1	Turbo	
Heat Pump Stage 2 + Electric Auxiliary Heat Module 2		*	*	*	*	1	0	1	0	1	Turbo	
Heat Pump Stage 2 + Electric Auxiliary Heat Module 2		*	*	*	*	1	0	1	0	1	Turbo	
Heat Pump Stage 1 + Electric Auxiliary Heat Module 1 & 2	1	*	1	0	1	0	1	1	0	1	Turbo	11
Heat Pump Stage 2 + Electric Auxiliary Heat Module 1 & 2		*	*	1	1	0	1	1	0	1	Turbo	
Heat Pump Stage 2 + Electric Auxiliary Heat Module 1 & 2		*	*	*	*	1	1	1	0	1	Turbo	
Emergency Heat	1	*	*	*	*	*	*	*	1	*	Turbo	12
Heating Zone Control	2	*	1	0	1	0	*	*	0	0	Low	13
Heating Zone Control		*	*	1	1	0	*	*	0	0	Low	
Heating Zone Control		*	*	*	*	1	*	*	0	0	Low	

Note:
 1: 24V signal
 0: No 24V signal
 *: 1 or 0
 The AUU will turn off if the 24V input cannot meet the table.

13.1 Error Display (Indoor Unit)

When the indoor unit encounters a recognized error, the operation lamp will flash in a corresponding series, the timer lamp may turn on or begin flashing, and an error code will be displayed. These error codes are described in the following table:

Display	Error Information	Solution
EC 07	ODU fan speed out of control	TS21
EC 0d	ODU malfunction	TS38
EC 51	ODU EEPROM parameter error	TS19
EC 52	ODU coil temp. sensor (T3) error	TS23
EC 53	ODU ambient temp. sensor (T4) error	TS23
EC 54	COMP. discharge temp. sensor (TP) error	TS23
EC 56	IDU coil outlet temp. sensor (T2B) error (Multi-Zone)	TS23
EC C1	Other IDU refrigerant sensor detects leakage (Multi-Zone)	TS35
EH 00	IDU EEPROM malfunction	TS19
EH 03	IDU fan speed out of control	TS21
EH 0A	IDU EEPROM parameter error	TS19
EH 0b	IDU main control board & display board communication error	TS39
EH 0E	Water-level alarm malfunction	TS25
EH 3A	External fan DC bus voltage is too low	TS35
EH 3b	External fan DC bus voltage is too high	TS35
EH 60	IDU room temp. sensor (T1) error	TS23
EH 61	IDU coil temp. sensor (T2) error	TS23
EH 62 / EH 66	Evaporator coil inlet temperature sensor T2B is in open circuit or short circuit	TS23
EH 65	Evaporator coil temperature sensor T2A is in open circuit or short circuit	TS23
EH 6A	Communication malfunction between indoor unit and external fan module	TS35
EH C1	Refrigerant sensor detects leakage	TS37
EH C2	Refrigerant sensor is out of range and leakage is detected	TS37
EH C3	Refrigerant sensor is out of range	TS36
EL 01	IDU & ODU communication error	TS20
EL 0C	System lacks refrigerant	TS23
EL 16	Communication malfunction between adapter board and outdoor main board	TS40
FH CC	Refrigerant sensor error	TS36
FL 09	Mismatch between the new and old platforms	TS40
PC 00	ODU IPM module protection	TS26
PC 01	ODU voltage protection	TS27
PC 02	Compressor top (or IPM) temp. protection	TS32
PC 03	Pressure protection (low or high pressure)	TS29
PC 04	Inverter compressor drive error	TS28
PC 0L	Low ambient temperature protection	TS33
----	IDUs mode conflict (Multi-Zone)	--
EH b3	Communication malfunction between wire & master control (for wired controller)	TS34

For other errors:

The display board may show a garbled code or a code undefined by the service manual. Ensure that this code is not a temperature reading.

Troubleshooting:

Test the unit using the remote control. If the unit does not respond to the remote, the indoor PCB requires replacement. If the unit responds, the display board requires replacement.

LED Flash Frequency:

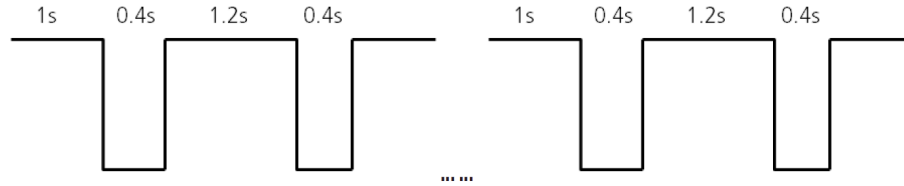

13.2 Information Inquiry

In order to enter engineering mode and check the data of the system, use the following steps:

- Ensure the unit is in standby status, or working normally in non-locked conditions.
- Press both "Power" and "Fan" buttons together simultaneously for 7 seconds until the remote screen shows "0". The "Auto", "Cool", "Dry", "Heat", and "Battery" icons will be displayed at the same time.
- Press the "Up" or "Down" button to choose the different channel number that you want to check. (from 0-30) on the remote control, and the display will show the parameter value.

Channel	Code	Meaning	Remark
0		Error code	Refer to next list of error codes; empty means no error
1	T1	Room Temperature	Actual data, °C/°F
2	T2	Indoor Coil Temperature	Actual data, °C/°F
3	T3	Outdoor Coil Temperature	Actual data, °C/°F
4	T4	Ambient Temperature	Actual data, °C/°F
5	TP	Discharge Temperature	Actual data, °C/°F
6	FT	Targeted Frequency	Actual data
7	Fr	Actual Frequency	Actual data
8	dL	Running Current	3.2A = 3
9	Ac	AC Voltage	
10	Sn	Reserved	
11	nA	Reserved	
12	Pr	Indoor Air Flow	Actual Data / 10
13	Lr	EXV opening steps	Actual Data / 8
14	lr	Indoor fan speed	Actual Data / 8
15	Hu	Humidity (if sensor is present)	Actual Data, %
16	TT	Set temperature including compensation	Actual Data, °C
17	nA	Reserved	
18	nA	Reserved	
19	Uo	Outdoor DC bus voltage	
20	oT	Target Frequency calculated by indoor	Without limitation
21	TA	Evaporator coil inlet temperature	Actual data, °C/°F
22	Tb	Evaporator coil inlet temperature	Actual data, °C/°F
23 ~30	nA	Reserved	

13 TROUBLESHOOTING

Note:

1. The channel number indicates a certain parameter value (check the table below).
2. The indoor unit display will show the code for 2 seconds, then the parameter value.
3. In engineering mode, the other keys or operations are invalid except for the "Power", "Up", "Down", and "OK" buttons.
4. To exit from engineering mode, press the "Power" and "Fan" buttons together for 2 seconds to quit and return to the home screen.
5. The engineering mode will automatically end and return to the home screen if there is no activity for 60 seconds.

Display	Error Information
EH 00	IDU EEPROM malfunction
EH 0A	IDU EEPROM parameter error
EL 01	IDU & ODU communication error
EH 6A	Communication error between the indoor unit and external fan module
EH 30	Parameters error of indoor external fan
EH 35	Phase failure of indoor external fan
EH 37	Indoor external fan zero speed failure
EH 38	Indoor external fan stall failure
EH 39	Out of step failure of indoor external fan
EH 3A	Low voltage protection of indoor external fan DC bus
EH 3b	Indoor external fan DC bus voltage is too high
EH 3E	Indoor external fan overcurrent fault
EH 3F	Indoor external fan module protection/hardware overcurrent protection
EH 03	IDU fan speed out of control
EC 51	ODU EEPROM parameter error
EC 52	ODU coil temperature sensor (T3) error
EC 53	ODU ambient temperature sensor (T4) error
EC 54	COMP. discharge temperature sensor (TP) error
EC 55	IGBT temperature sensor TH is in open circuit or short circuit
EC 0d	Outdoor unit malfunction
EH 60	IDU room temperature sensor (T1) error
EH 61	IDU coil temperature sensor (T2) error
EC 71	Outdoor external fan overcurrent fault
EC 75	Outdoor external fan module protection/hardware overcurrent protection
EC 72	Outdoor external fan phase failure
EC 74	Outdoor external fan current sampling bias fault
EC 73	Zero speed failure of outdoor unit DC fan
EC 07	ODU fan speed out of control
EH 65	Intelligent eye communication failure
EL 0C	Refrigerant leak detected
EH 0E	Water-level alarm malfunction
EH 0F	Intelligent eye malfunction

Display	Error Information
FH 07	Communication malfunction between indoor unit and auto-lifting panel
PC 00	ODU IPM module protection
PC 10	Over low voltage protection
PC 11	Over voltage protection
PC 12	DC voltage protection
PC 02	Top temperature protection of compressor or high temperature protection of IPM module
PC 40	Communication error between outdoor main chip and compressor driven chip
PC 41	Current Input detection protection
PC 42	Compressor start error
PC 43	Lack of phase (3 phase) protection
PC 44	Outdoor unit zero speed protection
PC 45	341PWM error
PC 46	Compressor speed malfunction
PC 49	Compressor over current protection
PC 06	Compressor discharge temperature protection
PC 08	Outdoor current protection
PH 09	Anti-cold air in heating mode
PC 0F	PFC module malfunction
PC 30	System overpressure protection
PC 31	System pressure is too low
PC 03	Pressure protection
PC 0L	Outdoor low ambient temperature protection
PH 90	Evaporator coil temperature too high
PH 91	Evaporator coil temperature too low
PC 0A	Condenser high temperature protection
PH 0C	Indoor unit humidity sensor failure
LH 00	Frequency limit caused by T2
LH 30	Indoor external fan current limit
LH 31	Indoor external fan voltage limit
LC 01	Frequency limit caused by T3
LC 02	Frequency limit caused by TP
LC 05	Frequency limit caused by voltage
LC 03	Frequency limit caused by current
LC 06	Frequency limit caused by PFC
LC 30	Frequency limit caused by high pressure
LC 31	Frequency limit caused by low pressure
LH 07	Frequency limit caused by a remote control
--	IDUs mode conflict (match with multi-outdoor unit)
NR	No malfunction and protection

13.3 Error Display (Outdoor Unit)

Display	Error Information	Solution
dF	Defrosting	Normal display, not error code
FC	Forced cooling	
EE 07	ODU fan speed out of control	TS12
EE 51	ODU EEPROM parameter error	TS10
EE 52	ODU coil temperature sensor (T3) error	TS14
EE 53	ODU ambient temperature sensor (T4) error	TS14
EE 54	Compressor discharge temperature sensor (T4) error	TS14
EE 55	ODU IPM module temperature sensor malfunction	TS33
EE 57	Refrigerant pipe temperature sensor error	TS14
EE 5C	Pressure sensor failure	TS35
EL 01	IDU & ODU communication error	TS11
EL 16	Communication malfunction between adapter board and ODU main board	TS36
PE 00	IPM Module Protection	TS17
PE 02	Compressor top (or IPM) temperature protection / Refrigerant sensor error	TS25
PE 06	Discharge temperature protection of compressor	TS23
PE 08	Outdoor overcurrent protection	TS15
PE 0A	High temperature protection of condenser	TS24
PE 0F	PFC Module Protection	TS22
PE 10	ODU low AC voltage protection	TS19
PE 11	ODU main control board DC bus high voltage protection	TS19
PE 12	ODU main control board DC bus low voltage protection / 341 MCE error	TS19
PE 30	System high pressure protection	TS27
PE 31	System low pressure protection	TS29
PE 40	Communication error between ODU main chip and compressor driven chip	TS21
PE 41	Compressor current sampling failure	TS32
PE 42	Compressor start failure of outdoor unit	TS15
PE 43	ODU compressor lack phase protection	TS31
PE 44	ODU zero speed protection	TS15
PE 45	ODU IR chip drive failure	TS32
PE 46	Compressor speed out of control	TS15
PE 49	Compressor overcurrent failure	TS15
LE 06	High temperature protection of Inverter Module (IPM)	TS26
PH 90	High temperature protection of evaporator	TS34
PH 91	Low temperature protection of evaporator	TS35

13.4 Outdoor Unit Point Check Function

- A check switch is included on the adapter board.
- Push SW4 to check the unit's status while running. The digital display shows the following codes each time SW4 is pushed.

Number of Presses	Display	Remark
0	Normal Display	Displays running frequency, running state, or malfunction code Defrosting mode: "dF" or alternative displays between running frequency and "dF" (each appears for 0.5s) Forced cooling mode: the LED displays "FC" or alternative displays between running frequency and "FC" (each appears for 0.5s)
01	Indoor unit capacity demand code	Actual data *HP*10 If capacity demand code is higher than 99, the decimal point of the high digit tube will be lighted. (For example, the digital display tube shows "5.0". 5.0 multiplied by 10 becomes 50, then added to 100 to become 150. The actual capacity demand = 150/10=15. If the digital display tube shows "60", the actual capacity demand = 60/10=6.0.) GA algorithm models display "--"
02	The frequency after the capacity requirement adapter	If the value is higher than 99, the decimal point of the high digit tube will be lighted.
03	Room Temperature (T1)	If the temperature is lower than 0°C (32°F), the digital display tube will show "0". If the temperature is higher than 70°C (158°F), the digital display tube will show "70".
04	Indoor Unit Evaporator Temperature (T2)	If the temperature is lower an -9°C (15.8°F), the digital display tube will show "-9". If the temperature is higher than 70°C (158°F), the digital display tube will show "70". If the outdoor unit is not connected, the digital display tube will show "--".
05	Condenser pipe temperature (T3)	
06	Outdoor ambient temperature (T4)	
07	Compressor discharge temperature (TP)	The display value is between 0~199°C (32°F~390.2°F). If the temperature is lower than 0°C (32°F), the digital display tube will show "0". If the temperature is higher than 99°C (210.2°F), the decimal point of the high digit tube will be lighted. (For example, the digital display tube shows "0.5", so 0.5 multiplied by 10 becomes 5, then added to 100 to become 105°C (221°F).)
08	AD value of current	The display value is a hex number. For example, the digital display tube shows "Cd", so $C*16^1+d*16^0=12*16+13=205$ means AD value is 205.
09	AD value of voltage	
10	Indoor unit Running Mode Code	Standby: 0, Cooling: 1, Heating: 2, Fan Only: 3, Drying: 4, Forced Cooling: 6, Defrost: 7, ECO: 9, Forced Defrosting: A, Self-Clean: B
11	Outdoor Unit Running Mode Code	
12	EXV Open Angle	Actual Data / 4 If the value is higher than 99, the decimal point of the high digit tube will be lighted. For example, the digital display tube shows "2.0". 2.0 multiplied by 10 becomes 20, then added to 100 to become 120. This means the EXV open angle is 120x4=480p.

13 TROUBLESHOOTING

Number of Presses	Display	Remark		
13	Frequency Limit Symbol AD value of current AD value of voltage Indoor unit Running Mode Code Outdoor Unit Running Mode Code	Bit 7	Frequency limit caused by IGBT radiator	The display value is a hex number. For example, the digital display shows 2A. The corresponding binary is 101010, so Bit5=1, Bit3=1, and Bit1=1. This means that a frequency limit may be caused by T3 or the current.
		Bit 6	Reserved	
		Bit 5	Reserved	
		Bit 4	Frequency limit caused by low temperature of T2. (LH00)	
		Bit 3	Frequency limit caused by T3. (LC01)	
		Bit 2	Frequency limit caused by TP. (LC02)	
		Bit 1	Frequency limit caused by current (LC03)	
		Bit 0	Frequency limit caused by voltage (LC05)	
14	Outdoor unit fan speed	If it is higher than 99, the decimal point of the high digit tube will be lighted. (For example, the digital display tube shows 2.0, so 2.0 multiplied by 10 becomes 20, then added to 100 to become 120. This value is multiplied by 8, so the current fan speed: 120*8=960.		
15	The average value of the temperature values detected by the high and low pressure sensors in the last 10 seconds of the compressor frequency calculation period	The displayed value is the actual value plus 60. (When the displayed value is 10, the actual value is -50.) When the displayed value is high than 99, the decimal point of the high digit tube will be lighted. (For example, if it displays 2.0, 2.0 multiplied by 10 becomes 20, then added to 100 to become 120, so the actual value is 60.)		
16	The temperature value detected by the high and low pressure sensor	When there is no pressure sensor, it is displayed as --		
17	AD value detected by the high and low pressure sensor	The display value is a hex number. For example, the digital display tube shows "Cd". $C*16^1+d*16^0=12*16+13=205$ means AD value is 205. When there is no pressure sensor, it is displayed as --		
18	The currently running communication protocol version	00-99		



MRCOOL®
COMFORT MADE SIMPLE

VersaPro® & Hyper Heat Central Ducted

The design and specifications of this product and/or manual are subject to change without prior notice.
Consult with the sales agency or manufacturer for details.