

*This product utilizes R-454B refrigerant*

# VersaPro<sup>®</sup>

# Packaged Heat Pump

## Installation Manual

### MODELS:

- MPH\*1HO13C



Read this manual carefully before installation and keep it where the operator can easily find it for future reference.

Due to updates and constantly improving performance, the information and instructions within this manual are subject to change without notice.

Version Date: August 27, 2025  
Please visit [www.mrcool.com/documentation](http://www.mrcool.com/documentation)  
to ensure you have the latest version of this manual.



## CONTENTS

<b>1</b>	<b>SAFETY</b> .....	2
<b>2</b>	<b>INSTALLATION</b> .....	9
	2.1 Inspection .....	9
	2.2 Limitations .....	9
	2.3 Pre-Installation Checks .....	9
	2.4 Rigging & Handling .....	9
	2.5 Unit Information & Dimensions .....	10
	2.6 Clearances .....	15
	2.8 Location Restrictions .....	12
<b>3</b>	<b>Area Limitations</b> .....	17
	3.1 Refrigerant Charge & Room Area Limitations .....	17
<b>4</b>	<b>Refrigerant Sensor</b> .....	20
	4.1 Refrigerant Sensor .....	20
<b>5</b>	<b>Airflow Performance</b> .....	21
<b>6</b>	<b>Duct, Condensate Drain, &amp; Filters</b> .....	24
	6.1 Duct Work .....	24
	6.2 Condensate Drain .....	25
	6.3 Filters .....	25
<b>7</b>	<b>Wiring</b> .....	26
	7.1 Power Supply .....	26
	7.2 Grounding .....	26
	7.3 Control Wiring .....	26
<b>8</b>	<b>Electric Heater</b> .....	29
	8.1 Electric Heater Kit Data .....	29
	8.2 Electric Heater Kit Information .....	30
<b>9</b>	<b>System Operating Information</b> .....	29
	9.1 Compressor Crankcase Heater .....	29
	9.2 Reversing Valve .....	29
	9.3 Wind Pressure Switch .....	29
	9.4 Protection Function .....	30
	9.5 LED status .....	31
	9.6 Defrost Mode .....	31
<b>10</b>	<b>Temperature Sensor Resistance Table</b> .....	32
<b>11</b>	<b>Thermostat Signals</b> .....	33
<b>12</b>	<b>Check-Up &amp; Troubleshooting</b> .....	34
	12.1 Operation Check-up .....	34
	12.2 Error Code & Troubleshooting .....	35
	12.3 Error Code of Control Board .....	36
	12.4 Troubleshooting Table .....	37
	12.5 Status Code .....	38
	12.6 Parameter Point Check Table .....	38
<b>13</b>	<b>Wiring Diagram</b> .....	39
<b>14</b>	<b>Disposal</b> .....	42

## Safety Precautions

### Read Before Using

Incorrect usage may cause serious damage or injury. Keep this manual for future reference. These instructions do not cover all of the different variations of systems nor does it provide for every possible contingency to be met in connection with installation.



Indicates the most serious hazards which will result in severe personal injury, property and/or product damage, or death.



Indicates hazards which could result in moderate personal injury and/or property and product damage.

NOTE

Indicates suggestions which will result in enhanced installation, reliability, or operation.

Symbols Displayed on Unit		
	<b>WARNING</b>	This symbol shows that this appliance uses a mild flammable refrigerant. If the refrigerant leaks and is exposed to an external ignition source, there is risk of a fire.
	<b>CAUTION</b>	This symbol shows that the appliance shall be installed, operated, and stored in a room with a floor area not less than the minimum room area.
	<b>CAUTION</b>	This symbol shows that the operation manual should be read carefully.
	<b>CAUTION</b>	This symbol shows that a service personnel should be handling this equipment with reference to the installation manual.
	<b>CAUTION</b>	This symbol shows that information is available such as the operating manual or installation manual.

## WARNING

- These instructions are intended as an aid to qualified, licensed service personnel for proper installation, adjustment and operation of this unit. Read these instructions thoroughly before attempting installation or operation.
- Failure to follow these instructions may result in improper installation, adjustment, service or maintenance possibly resulting in fire, electrical shock, property damage, personal injury or death.
- MRCOOL® warranty does not cover any damage or defect to the heat pump caused by the attachment or use of any components, accessories or devices (other than those authorized by the MRCOOL®) into, onto or in conjunction with the heat pump. You should be aware that the use of unauthorized components, accessories or devices may adversely affect the operation of the heat pump and may also endanger life and property. MRCOOL® disclaimer for any responsibility for such loss or injury resulting from the use of such unauthorized components, accessories or devices.
- Disconnect all power to the unit before starting maintenance. Failure to do so can result in severe electrical shock or death.
- Do not, under any circumstances, connect return ductwork to any other heat producing device such as a fireplace insert, stove, etc. Unauthorized use of such devices may result in fire, carbon monoxide poisoning, explosion, property damage, severe personal injury or death.
- The unit must be permanently grounded. A grounding lug is provided. Failure to ground this unit can result in fire or electrical shock causing property damage, severe personal injury or death.
- Only electric heater kits supplied by MRCOOL® as described in this publication have been designed, tested, and evaluated by a nationally recognized safety testing agency for use with this unit. Use of any other manufactured electric heaters installed within this unit may cause hazardous conditions resulting in property damage, fire, body injury or death.



## WARNING: PROPOSITION 65

- This appliance contains fiberglass insulation. Respirable particles of fiberglass are known to the state of California to cause cancer.



## GENERAL WARNINGS FOR SAFETY

- DO NOT use means to accelerate the defrosting process or to clean other than those recommended by the MRCOOL®.
- The appliance shall be stored in a area that does not have continuously operating ignition sources (for example: open flames, and operating gas appliance, or an operating electric heater).
- DO NOT pierce/puncture refrigerant lines or burn the unit.
- Be aware that refrigerants may not contain an odor.



## GENERAL WARNINGS FOR SAFETY

- **Any person who is involved with working on or opening a refrigerant circuit should hold a current valid certificate from an industry-accredited assessment authority, which authorized their competence to handle refrigerants safely in accordance with an industry recognized assessment credential.**
- **Servicing shall only be performed as recommended by the equipment MRCOOL®.**
- **Maintenance and repair requiring the assistance of other skilled personnel shall be carried out under the supervision of a person competent in the use of flammable refrigerants.**
- **Prior to beginning work on systems containing flammable refrigerants, safety checks are necessary to minimize the risk of ignition.**

### REFRIGERANT OIL

- **These units use R454B refrigerant. Use only R454B approved service equipment. These units use a POE oil that readily absorbs moisture from the atmosphere. To limit this "hygroscopic" action, the system should remain sealed whenever possible. If a system has been open to the atmosphere for more than 4 hours, the compressor oil must be replaced. Never break a vacuum with air and always change the driers when opening the system for component replacement.**

**When repairing the refrigerating system, comply with the following precautions prior to conducting work on the system.**

- **Shall be undertaken according to the controlled procedures so as to minimize the risk of the presence of flammable gases or vapors while the work is being performed.**
- **All maintenance staff and others working in the local area shall be instructed on the nature of work being carried out. Work in confined spaces shall be avoided.**
- **The area shall be checked with an appropriate refrigerant detector prior to and during work, to ensure the technician is aware of potentially toxic or flammable environment.**

**Ensure that the leak detection equipment being used is suitable for use with all applicable refrigerants, i.e. non-sparking, adequately sealed, or intrinsically safe.**

- **If any brazing/welding is to be conducted on the refrigerating equipment or any associated parts, appropriate fire extinguishing equipment shall be available and easily accessible. Have dry powder or CO2 fire extinguisher adjacent to the charging area.**
- **When carrying out work in relation to a refrigerating system that involves exposing any pipe work, no sources of ignition shall be used in such a manner that it may lead to the risk of fire or explosion.**

**All possible ignition sources, including cigarette smoking, should be kept sufficiently far away from the site of installation, repair, or removal and disposal of the unit, during which refrigerant can possibly be released into the surrounding space. Prior to beginning work, the area around the equipment is to be surveyed to make sure that there are no flammable hazards or ignition risk. "No Smoking" signs shall be clearly displayed.**

**Ensure that the area is in the open or that it is adequately ventilated before opening the system or conduction any hot work. A degree of ventilation shall continue during the period that the work is**



## GENERAL WARNINGS FOR SAFETY CONT.

carried out. The ventilation should safely disperse any released refrigerant and preferably expel it externally into the surroundings.

- Where electrical components are being changed, they shall be fit according to their purpose and to the correct specification. At all times MRCOOL® maintenance and service guidelines shall be followed. If in doubt, consult MRCOOL® customer service department for assistance. The following checks shall be applied to installations using flammable refrigerants: The actual refrigerant charge is in accordance with the room size within which the refrigerant containing parts are installed.
- The ventilation machinery and outlets are operating adequately and are not obstructed.
- If an indirect refrigerating circuit is being used, the secondary circuit shall be checked for the presence of refrigerant.
- Equipment marking must remain visible and legible. Markings and signs that are illegible shall be corrected.

Refrigerating pipe or components are installed in a position where they are unlikely to be exposed to any substances which may corrode refrigerant containing components, unless the components are constructed of materials that are inherently resistant to corrosion or suitably protected against corrosion. Repair and maintenance of electrical components shall include initial safety checks and component inspection procedures. If a fault exists that could compromise safety, then no electrical supply shall be connected to the circuit until the fault has been dealt with satisfactorily.

If the fault cannot be corrected immediately but it is necessary to continue operation, an adequate temporary solution shall be used. This shall be reported to the owner of the equipment so that all parties are advised. Initial safety checks shall include:

- That capacitors are discharged: this shall be done in a safe manner to avoid the possibility of sparking.
- That no live electrical components and wiring are exposed while charging, recovering, or purging the system.
- That there is continuity of proper grounding.

Sealed electrical components shall be replaced.

Intrinsically safe components must be replaced.

Check that cabling will not be subject to wear, corrosion, excessive pressure, vibration, sharp edges, or any other adverse environmental effects. The check shall also take into account the effects of aging or continual vibration from sources such as compressors or fans.

Under no circumstances shall potential sources of ignition be used while searching for or detection of refrigerant leaks. A halide torch (or any other detector using a naked flame) shall not be used.

Electronic leak detectors may be used to detect refrigerant leaks but, in the case of flammable refrigerants, the sensitivity may not be adequate, or may need re-calibration. (Detection equipment shall be calibrated in a refrigerant-free area). Ensure that the detector is not a potential source of ignition and is suitable for the refrigerant used. Leak detection equipment shall be set at a percentage of the LFL of the refrigerant and shall be calibrated for the refrigerant employed, and the appropriate percentage of gas (25% maximum) is confirmed.

If a leak is suspected, all naked flames shall be removed/extinguished.

If a leakage of refrigerant which requires brazing is found, all of the refrigerant shall be recovered from the system, or isolated (by means of shut off valves) in a part of the system remote from the leak.

Leak detection fluids are also suitable for use with most refrigerants but the use of detergents containing chlorine shall be avoided as the chlorine may react with the refrigerant and corrode the copper pipe-work.

Note: Examples of leak detection fluids are

Bubble method, When breaking into the refrigerant circuit to make repairs - or for any other purpose - conventional procedures shall be used. However, for flammable refrigerants it is important that best practices be followed, since flammability is a consideration. The following procedure shall be adhered to:



## GENERAL WARNINGS FOR SAFETY CONT.

- Safely remove refrigerant following local and national regulations.
- Evacuate
- Purge the circuit with inert gas.
- Evacuate
- Continuously flush or purge with inert gas when using flame to open circuit; and,
- Open the circuit

The refrigerant charge shall be recovered into the correct recovery cylinders if venting is not allowed by local and national codes. For appliances containing flammable refrigerants, the system shall be purged with oxygen-free nitrogen to render the appliance safe for flammable refrigerants. This process might need to be repeated several times. Compressed air or oxygen shall not be used for purging refrigerant systems.

For appliances containing flammable refrigerants, refrigerant purging shall be achieved by breaking the vacuum in the system with oxygen-free nitrogen and continuing to fill until the working pressure is achieved, then venting to atmosphere, and finally pulling down to a vacuum. This process shall be repeated until no refrigerant is within the system. When the final oxygen-free nitrogen charge is used, the system shall be vented down to atmospheric pressure to enable work to take place. The outlet for the vacuum pump shall not be close to any potential ignition sources, and ventilation shall be available.

Ensure that contamination of different refrigerants does not occur when using charging equipment. Hoses or lines shall be as short as possible to minimize the amount of refrigerant they contain.

When using a refrigerant tank with a siphon to add refrigerant, the refrigerant tank should be placed upright. When using a refrigerant tank without a siphon to add refrigerant, the refrigerant tank should be placed upside down. Ensure that the refrigeration system is grounded prior to charging the system with refrigerant.

In general, R454B doesn't have a siphon tube or dip tube in the tank. For this situation, they must be charged in liquid form to prevent fractionation of the blended refrigerant and that requires the jug to be inverted during charging.

Label the system when charging is complete (if it is not already labeled).

Take extreme care to not overfill the refrigeration system.

Prior to recharging the system, it shall be pressure-tested with the appropriate purging gas. The system shall be leak-tested on completion of charging but prior to commissioning. A follow up leak test shall be carried out prior to leaving the site.

Before carrying out this procedure, it is essential that the technician is completely familiar with the equipment and all its details. It is recommended that all refrigerants are recovered safely. Prior to the task being carried out, and oil and refrigerant sample shall be taken in case analysis is required prior to re-use of reclaimed refrigerant. It is essential that electrical power is available before the task is commenced.

- a. Become familiar with the equipment and its operation.
- b. Isolate the system electrically.
- c. Before attempting the procedure ensure that:
  - Mechanical handling equipment is available, if required, for handling refrigerant cylinders;
  - All personal protective equipment is available and being used correctly;
  - The recovery process is supervised at all times by a competent person;
  - Recovery equipment and cylinders conform to the appropriate standards.
- d. Pump down the refrigerant system, if possible
- e. If a vacuum is not possible, make a manifold so that the refrigerant can be removed from various parts of the system.
- f. Make sure that the cylinder is situated on the scales before recovery takes place.
- g. Start the recovery machine and operate it in accordance with the manufacturer's instructions.
- h. Do not overfill cylinders. (No more than 80% volume liquid charge).
- i. Do not exceed the maximum working pressure of the cylinder, even temporarily.
- j. When the cylinders have been filled correctly and the process has been completed, make sure that the cylinders and the equipment are removed from the site promptly and all isolation valves on the



## GENERAL WARNINGS FOR SAFETY CONT.

the cylinders and the equipment are removed from the site promptly and all isolation valves on the equipment are closed off.

- g. Recovered refrigerant shall not be charged into another refrigeration system unless it has been cleaned and checked.

Equipment shall be labeled stating that it has been de-commissioned and emptied of refrigerant. The label shall be dated and signed. Ensure that there are labels on the equipment stating the equipment contains flammable refrigerant.

When removing refrigerant from a system, either for servicing or decommissioning, it is recommended that all refrigerants are removed safely.

When transferring refrigerant into cylinders, ensure that only appropriate refrigerant recovery cylinders are employed. Ensure that the correct numbers of cylinders for holding the total system charge is available. All cylinders to be used are designated for the recovered refrigerant and labeled for that refrigerant (i.e. special cylinders for the recovery of refrigerant). Cylinders shall be complete with pressure-relief valve and associated shut-off valves in good working order. Empty recovery cylinders are evacuated and, if possible, cooled before recovery occurs.

The recovery equipment shall be in good working order with a set of instructions concerning the equipment that is at hand and shall be suitable for the recovery of the flammable refrigerant. If in doubt, MRCOOL® should be consulted. In addition, a set of calibrated weighing scales shall be available and in good working order. Hoses shall be complete with a leak-free disconnect couplings and in good condition.

The recovered refrigerant shall be processed according to the local legislation in the correct recovery cylinder, and the relevant waste transfer note arranged. DO NOT mix refrigerants in the recovery units and especially not in cylinders.

If compressors or compressor oils are to be removed, ensure that they have been evacuated to an acceptable level to make certain that flammable refrigerant does not remain within the lubricant. The compressor body shall not be heated by an open flame or other ignition sources to accelerate this process. When oil is drained from a system, it shall be carried out safely. DO NOT use the air conditioner for other purposes.

In order to avoid any quality deterioration, do not use the unit for the cooling of precision instruments, food, plants, animals, or works of art.

Before cleaning, be sure to stop the operation, turn the breaker off or unplug the supply cord, otherwise electric shock or injury may occur.

In order to avoid electric shock or fire, make sure that an earth ground detector is installed.

Never touch the air outlet or the horizontal blades while the swing flap is in operation. Your fingers may become caught or the unit may break put any objects into the air inlet or touching the fan at high speed can be dangerous. Never inspect or service the unit by yourself.

Ask a qualified service person to perform this task.

DO NOT dispose of this product as unsorted municipal waste. This waste should be collected separately for special treatment.

DO NOT dispose of electrical appliances as unsorted municipal waste. Use separate collection facilities. Contact your local government for information regarding the connection systems available.

If electrical appliances are disposed of in landfills or dumps, hazardous substances can leak into the groundwater and get into the food chain, harming your health and well-being.

When the system is installed and operates in a small room, it is required to maintain the concentration of the refrigerant below the limit, in case a leak occurs. Otherwise, oxygen in the room may be affected, resulting in a serious accident.

The refrigerant in the air conditioner is safe and normally does not leak.

If the refrigerant leaks into the room and comes into contact with a the fire of a burner, heater, or a

## GENERAL WARNINGS FOR SAFETY CONT.

cooker, harmful gas could be released.

Turn off any combustible heating devices, ventilate the room, and contact the dealer where you purchased the unit.

**DO NOT** use the air conditioner until a service person confirms that the refrigerant leak is repaired.

Keep ventilation openings clear of obstructions.

## CAUTION

In order to avoid electric shock make sure that the unit is grounded and that the ground wire is not connected to a gas or water pipe, lightning conductor, or telephone ground wire.

- DO NOT operate the air conditioner with wet hands.
- DO NOT operate the air conditioner when using a room fumigation-type insecticide. Failure to observe this precaution could cause the chemicals to become deposited in the unit which could endanger the health of those who are hypersensitive to chemicals. It may also cause the refrigerant sensor to alarm.
- To avoid oxygen deficiency, ventilate the room sufficiently if equipment with a burner is used together with the air conditioner.
- Arrange the drain hose to ensure smooth drainage. Incomplete drainage may cause damage to the building, furniture, etc.
- Never touch the internal parts of the controller. DO NOT remove the front panel. Some parts inside are dangerous to touch and operation problems may occur.
- Attention is drawn to the fact that additional transportation regulations may exist with respect to equipment or the configuration of the equipment permitted to be transported together will be determined by the applicable transport regulations.
- Signs for similar appliances used in a work area are generally address by local regulations and give the minimum requirements for the provision of safety and/or health signs for a work location.
- Storage package protection should be constructed in such a way that mechanical damage to the equipment inside the package will not cause a leak of the refrigerant charge.
- The maximum number of pieces of equipment permitted to be stored together will be determined by local regulations.
- All required signs are to be maintained and employers should ensure that employees receive suitable and sufficient instruction and training on the meaning of appropriate safety signs and the actions that need to be taken in connection with these signs.
- The effectiveness of signs should not be diminished by too many signs being places together.
- Any pictograms used should be as simple as possible and contain only essential details.
- The storage of the appliance should be in accordance with the applicable regulations or instructions, whichever is more stringent.
- DO NOT place appliances which produce open flame in places exposed to the unit as it may cause incomplete combustion or deformation of the unit due to the heat.
- DO NOT install the air conditioner in a location where flammable gas may leak out. If the gas leaks out and stays around the air conditioner a fire may break out.

## WARNING

This appliance uses R454B refrigerant.



**WARNING**

These instructions are exclusively intended for qualified contractors and authorized installers. Work on the refrigerant circuit with mild flammable refrigerant in safety group A2L. may only be carried out by authorized heating contractors. These contractors must be trained in accordance with UL 60335-2-40, Section HH. The certificate of competence from an industry accredited body is required. Work on electrical equipment may only be carried out by a qualified electrician. Before initial commissioning, all safety related points must be checked by the particular certified contractors. The system must be commissioned by the system installer or a qualified person authorized by the installer.

**CAUTION: LOCATION**

Only use this unit in well-ventilated spaces and ensure that there are no obstructions that could impede the airflow into and out of the unit.

DO NOT USE THIS UNIT IN THE FOLLOWING LOCATIONS:

- Locations with mineral oil.
- Locations with saline atmospheres, such as seaside locations.
- Locations with sulfurous atmospheres, such as near natural hot springs.
- Where high voltage electricity is present, such as in certain industrial locations.
- On vehicles or vessels, such as trucks or ferry boats.
- Where exposure to oily or very humid air may occur, such as kitchens.
- In proximity to sources of electromagnetic radiation, such as high-frequency transmitters or other high strength radiation devices.

**CAUTION**

A manufactured (mobile) home installation must conform with the Manufactured Home Construction and Safety Standard, Title 24 CFR, Part 3280, or when this Standard is not applicable, the Standard for Manufactured Home Installations (Manufactured Home Sites, Communities and Set-Ups), ANSI/NCS A225.1, and/or MH Series Mobile Homes, CAN/CSA Z240.

**CAUTION**

This appliance is not intended for use by persons (including children) with reduced physical, sensory, or mental capabilities, or lack of experience and knowledge, unless they have been given supervision or instruction concerning use of the appliance by a person responsible for their safety. Children should be supervised to ensure that they do not play with the appliance.

**WARNING**

**Ensure the unit is mounted securely.**

The pipe-work including piping material, pipe routing, and installation shall include protection from physical damage in operation and service, and be in compliance with national and local codes and standards, such as ASHRAE15, ASHRAE 15.2, IAPMO Uniform Mechanical Code, ICC International Mechanical Code. Inspection prior to being covered or enclosed, or CSA B52. All field joints shall be accessible for inspection prior to being covered or enclosed.

# 2 INSTALLATION

## 2.1 Inspection

As soon as unit is received, it should be inspected and noted for possible shipping damage during transportation. It is carrier's responsibility to cover the cost of shipping damage. MRCOOL® or distributor will not accept the claims from dealer for any transportation damage.

## 2.2 Limitations

If components are to be added to a unit, they must meet local codes and are to be installed at the dealer's and / or the customer's expense.

The size of unit for proposed installation should be based on heat loss / heat gain calculations made in accordance with industry recognized procedures identified by the Air Conditioning Contractors of America.

## 2.3 Pre-Installation Checks

Before installation, carefully check the following:

1. Unit should be installed in accordance with national and local safety codes, including but not limit to ANSI/ NFPS No. 70 or Canadian Electrical Code Part 1, C22.1, local plumbing and wastewater codes and any other applicable codes.
2. For rooftop installation, be sure the structure has enough strength to support the weight of unit. Unit should be installed on roof curb and leveled.
3. For ground level installation, a level slab should be used.
4. Condenser airflow should not be restricted.
5. On applications when a roof curb is used, the unit must be positioned on the curb so the front of the unit is tight against the curb.



### WARNING

**Check the electric wire, water and gas pipeline layout inside the wall, floor and ceiling before installation. Do not implement drilling unless confirm safety with the user, especially for the hidden power wire. An electro-probe can be used to test whether a wire is passing by at the drilling location, to prevent physical injury or death caused by insulation broken cords.**



### WARNING

**Check the power supply before installation. Ensure that the power supply must be reliably grounded following local, state and National Electrical Codes. If not, for example, if the ground wire is detected charged, installation is prohibited before it is rectified. Otherwise, there is a risk of fire and electric shock, causing physical injury or death.**

## 2.4 Rigging & Handling

Exercise care when moving the unit. Do not remove any packaging until the unit is near the place of installation. Rig the unit by attaching chain or cable slings to the lifting holes provided in the base rails. Spreader bars, whose length exceeds the largest dimension across the unit, MUST be used across the top of the unit.

### CAUTION

Before lifting, make sure the unit weight is distributed equally on the rigging cables so it will lift evenly. Units may be moved or lifted with a forklift. Slotted openings in the base rails are provided for this purpose.

### CAUTION

All panels must be secured in place when the unit is lifted. The condenser coils should be protected from rigging cable damage with plywood or other suitable material.

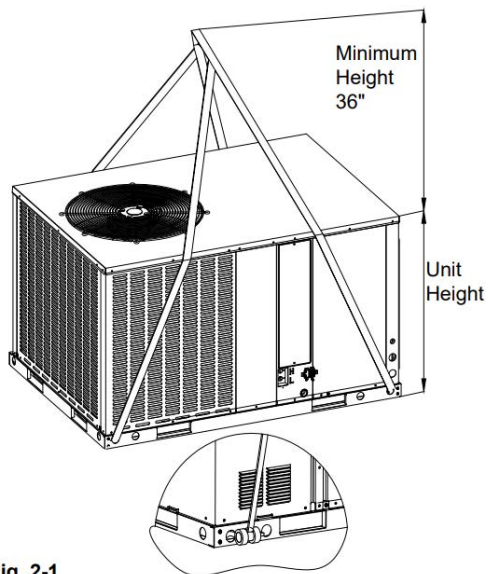

Fig. 2-1

## 2.5 Unit Information & Dimensions

For 2 ton to 3 ton unit

\*The below figure is for reference purposes only.

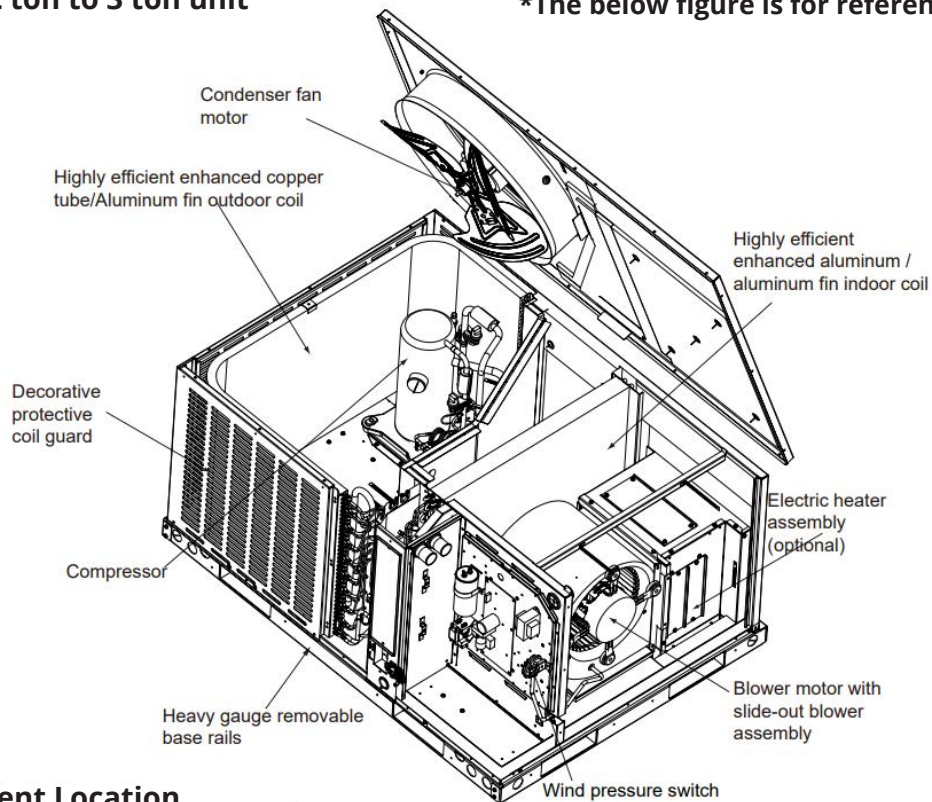

Fig. 2-2 Component Location



For 2 ton to 3 ton unit

\*The below figures are for reference purposes only.

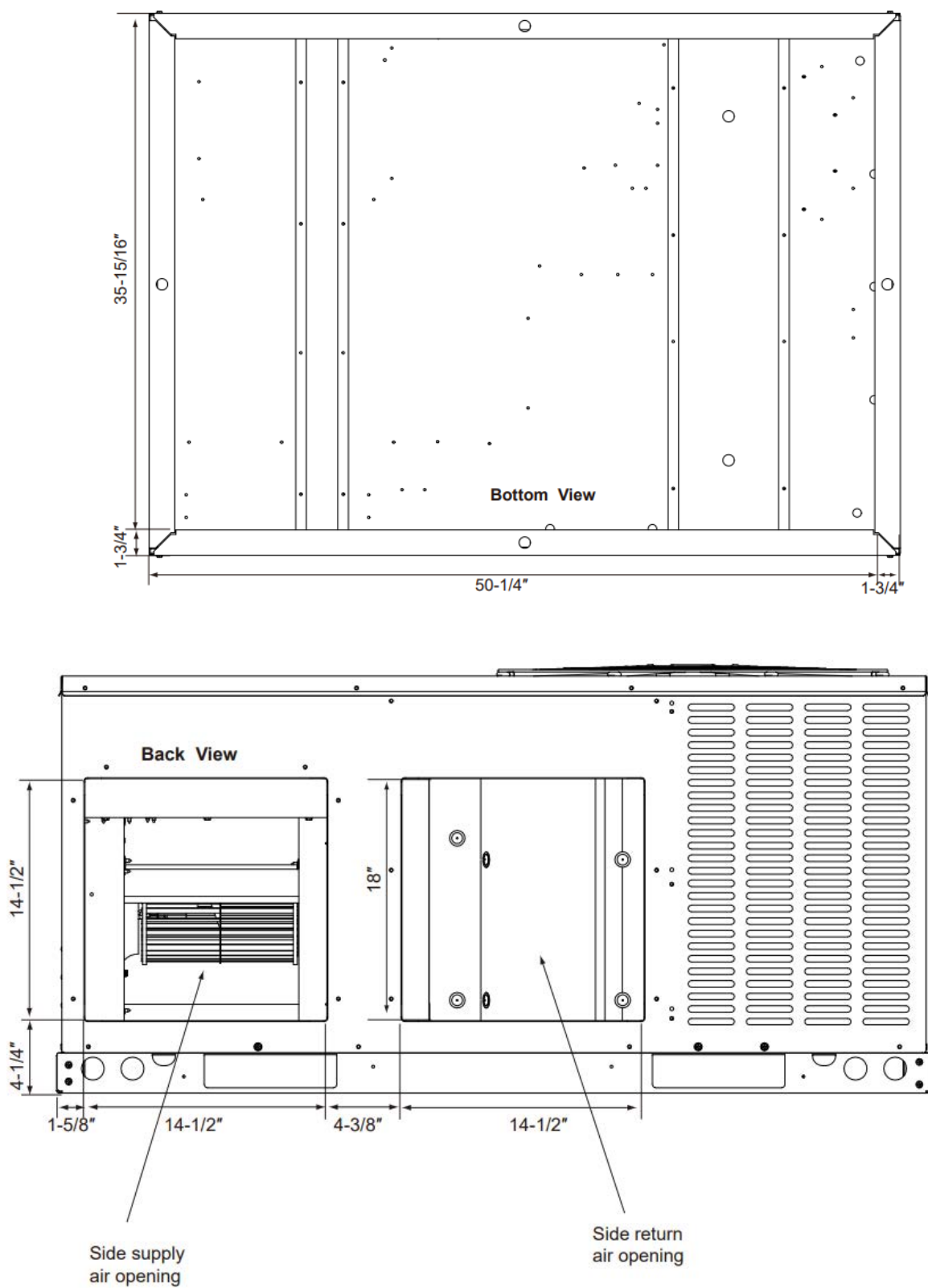

Fig. 2-4 Dimensions Back and Bottom

## 2 INSTALLATION

For 3.5 ton to 5 ton unit

\*The below figure is for reference purposes only.

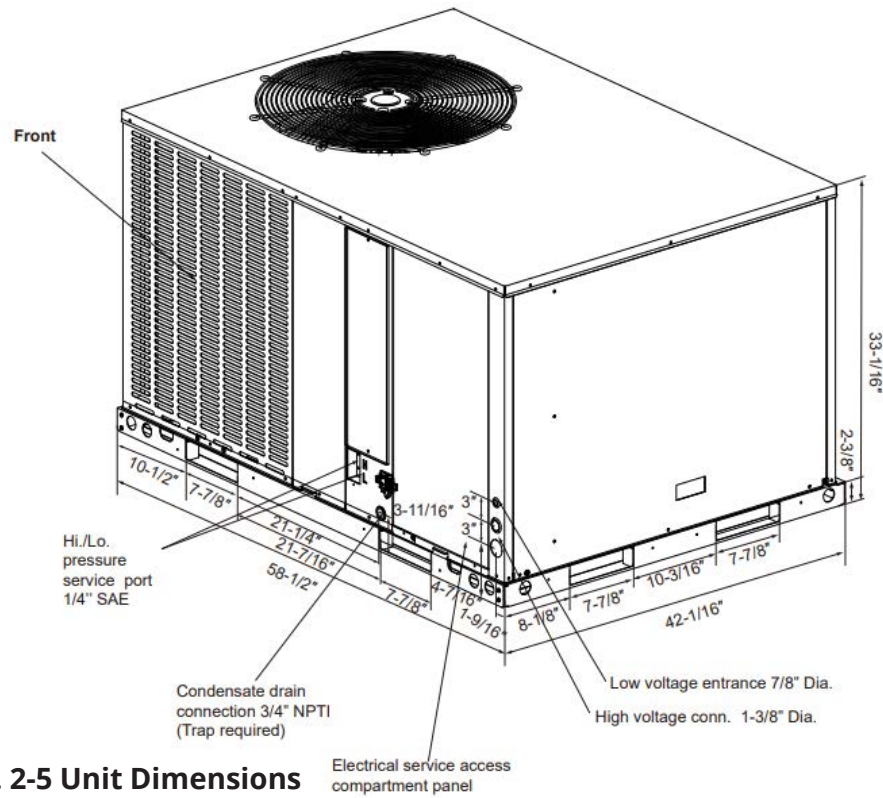

Fig. 2-5 Unit Dimensions

For 3.5 ton to 5 ton unit

\*The below figures are for reference purposes only.

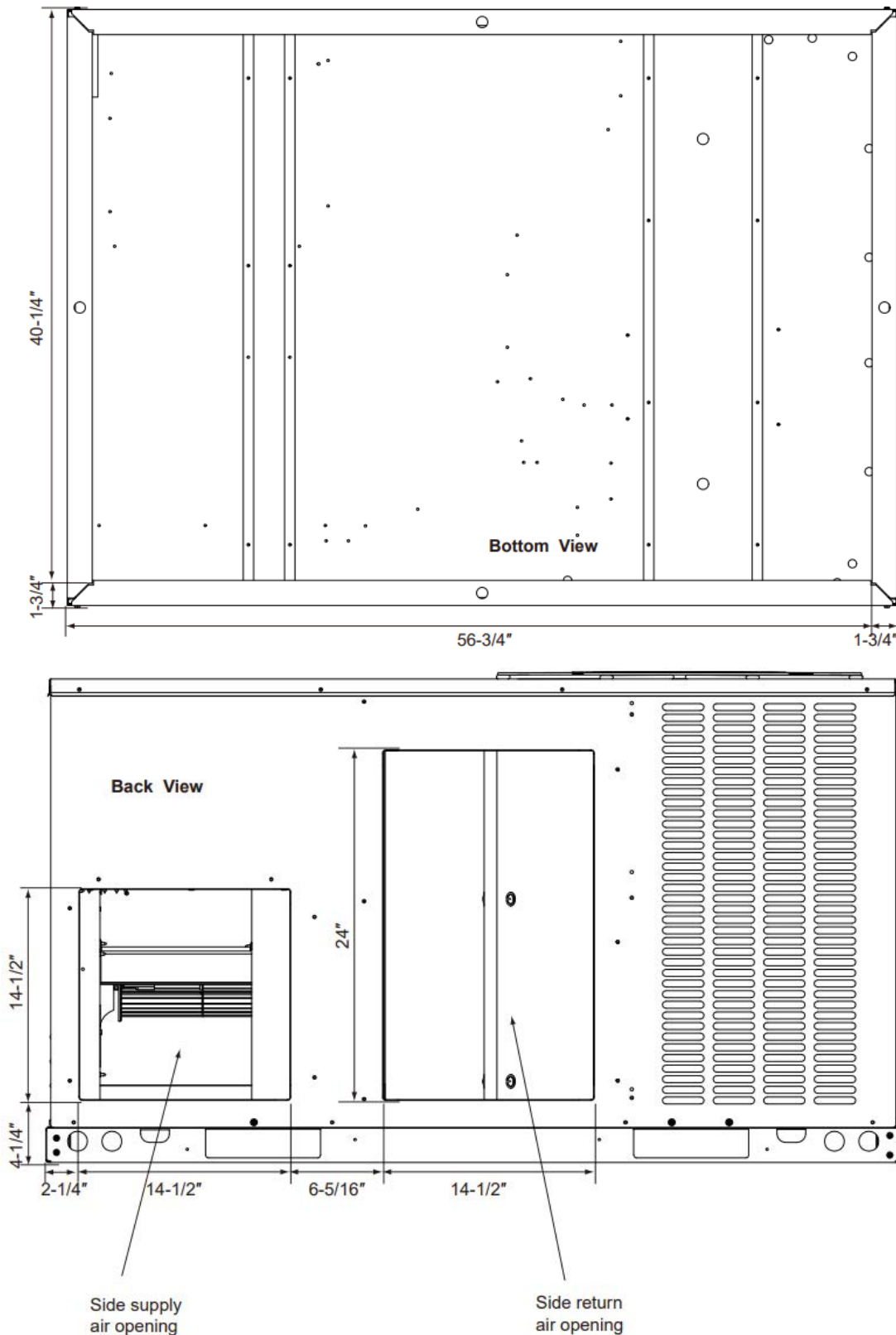

Fig. 2-6 Dimensions Back and Bottom

# 2 INSTALLATION

## 2.6 Clearances

All units require certain clearance for proper operation and service. Refer to Table 2.6 for the clearances required for construction, servicing and proper unit operation.

**Table 2.6- Unit Clearance**

Direction	Distance (in.)	Direction	Distance (in.)
Top <sup>1</sup>	60	Right	30
Front	30	Left	24
Rear	18 <sup>2</sup>	Bottom <sup>3</sup>	0

Duct clearance: 1 inch clearance for all sides of air supply duct.

1. Units must be installed outdoors. Over hanging structure or shrubs should not obscure condenser air discharge outlet.
2. The minimum clearance without economizer/fresh air damper. For distance with economizer/fresh air damper, please refer to the installation instructions provided with the accessory.
3. Units may be installed on combustible floors made from wood or class A, B or C roof covering materials.

### NOTE

For units installed with a roof curb, the minimum clearance may be reduced from 1 inch to 1/2 inch between combustible roof curb material and this supply air duct.

### NOTE

A unit with electric heaters with an inlet or outlet duct that penetrates the building structure supporting the unit shall be provided with a mounting base of noncombustible material designed that, after the unit is installed, there will be no open passages through the supporting structure that would permit flame or hot gases from a fire originating in the space below the supporting structure to travel to the space above that structure. If the unit is intended to be installed on a supporting structure of combustible material, the base shall be designed that the required clearance will be maintained between the supporting structure, unit, plenum, and attached duct. Spacers necessary to provide required clearances shall be attached to the unit mounting base, and shall extend not less than 3in (76mm) below the upper surface of the supporting structure, except that, in a unit designed for use only in a mobile home, the distance shall be not less than 3/4in (19mm).

### NOTE

Make sure that the condensate drain side is not higher than the other side.

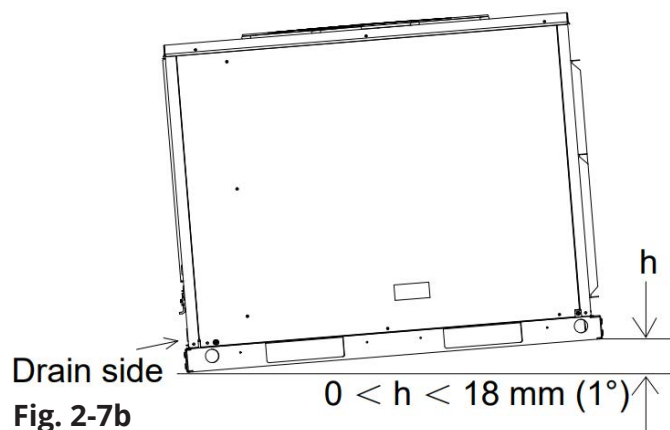
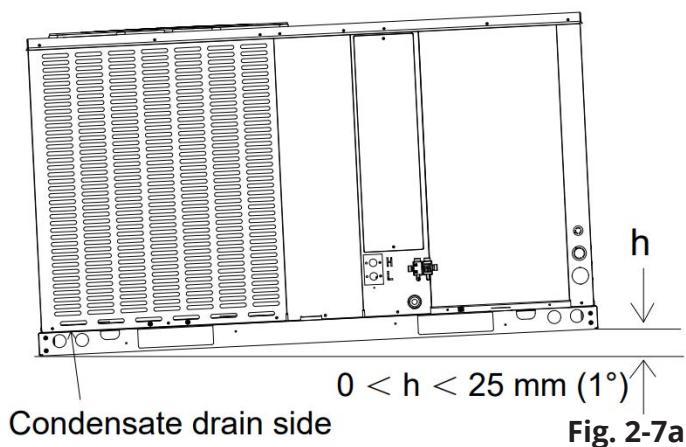

## 2.7 Location Restrictions

1. Ensure the top discharge area is unrestricted for at least 60 inches above the unit.
2. DO NOT locate the outdoor unit near bedrooms since normal operational sounds may be objectionable.
3. Position the unit to allow adequate space for unobstructed airflow, wiring, refrigerant lines, and serviceability.
4. Allow a minimum of 12in. clearance on one side of the access panel to a wall and a minimum of 24in. on the adjacent side of the access panel.
5. Maintain a distance of 24in. between units.
6. Position the unit where water, snow, or ice from the roof or overhang cannot fall directly on the unit.
7. See Fig. 2-8 and Fig. 2-9

### Cold Climate Considerations

- Units should be elevated 3-12 inches above the pad or rooftop, depending on local weather. This additional height will allow drainage of snow and ice melted during defrost cycle prior to its refreezing. Ensure that the drain holes in the units base pan are not obstructed, preventing damage of defrosting water (Fig. 2-9).
- If possible, avoid locations that are likely to accumulate snow drifts. If not possible, a snow drift barrier should be installed around the unit to prevent a build-up of snow on the sides of the unit.

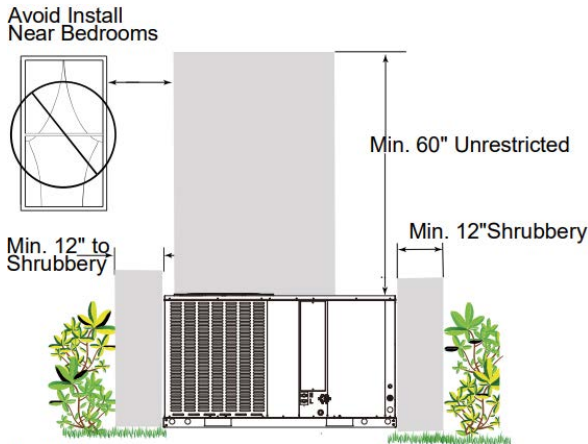

Fig. 2-8

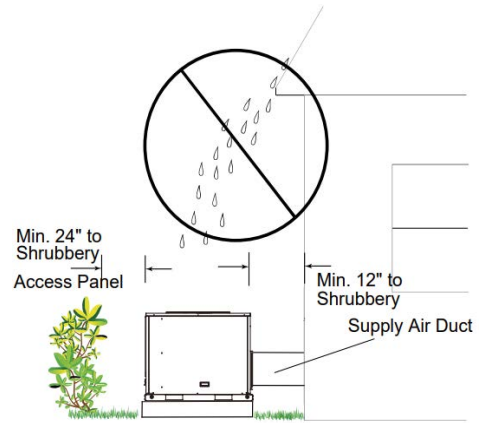

Fig. 2-9

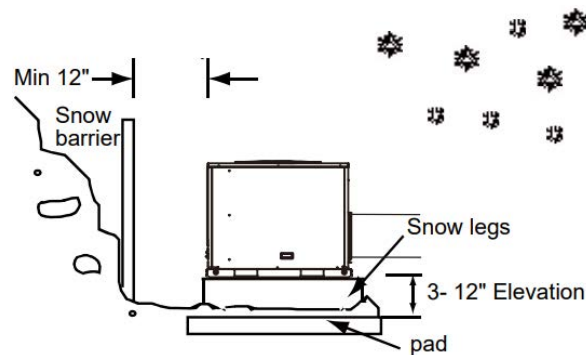

Fig. 2-10

# 3 AREA LIMITATIONS

## 3.1 Refrigerant Charge & Room Area Limitations

### Room Size Restriction

In UL/CSA 60335-2-40, R454B refrigerant is classified as class A2L, which is mildly flammable. Therefore, R454B refrigerant will limit the area of the rooms being served by the system. Similarly, the total amount of refrigerant in the system shall be less than or equal to the allowable maximum refrigerant charge. The allowable maximum refrigerant charge depends on the area of the rooms being served by the system.

### SECTION TERMINOLOGY

**Mc:** the actual refrigerant charge in the system  
**A:** the actual room area where the appliance is installed  
**Amin:** the required minimum room area  
**Mmax:** the allowable maximum refrigerant charge in a room  
**Qmin:** the minimum circulation airflow

**Anvmin:** the minimum opening area for connected rooms  
**TAmin:** the total area of the conditioned space (for appliances serving one or more rooms with an air duct system)  
**TA:** The total area of the conditioned space connected by air ducts.

### Room Area Calculation Requirements

#### CAUTION

The space considered shall be any space which contains refrigerant-containing parts or into which refrigerant could be released. The room area (A) of the smallest, enclosed, occupied space shall be used in the determination of the refrigerant quantity limits.

For determination of room area (A) when used to calculate the refrigerant charge limit, the following shall apply. The room area (A) shall be defined as the room area enclosed by the projection to the base of the walls, partitions, and doors of the space in which the appliance is installed. Spaces connected by only drop ceilings, ductwork, or similar connections shall not be considered a single space. Units mounted higher than 70-55/64 inches and spaces divided by partition walls that are no higher than 62-63/64 inches shall be considered a single space. Rooms on the same floor and connected by an open passageway between the spaces can be considered a single room when determining compliance to Amin, if the passage way complies with all of the following:

1. It is a permanent opening
2. It extend to the floor.
3. It is intended for people to walk through.

The area of the connected rooms, on the same floor, connected by permanent opening in the walls an/or doors between occupied spaces, including gaps between the wall and the floor, can be considered a single room when determining compliance to Amin, provided all of the following conditions are met as Fig. 2-11.

#### 1. Low level opening

- The opening shall not be less than Anvmin in tables 2-2.
- The area of any openings above 11-13/16 inches from the floor shall not be considered in determining compliance with Anvmin.
- At least 50% of the opening area of Anvmin shall be below 7-7/8 inches from the floor.
- The bottom of the opening is not more than 3-15/16 inches from the floor.
- The opening is permanent opening that cannot be closed.
- For openings extending to the floor the height shall not be less than 25/32 inches above the surface of the floor covering.

#### 2. High level opening

- The opening shall not be less than 50% of Anvmin in Table 2-2.
- The opening is a permanent opening that cannot be closed.
- The opening shall be at least 59 inches above the floor

- The height of the opening is not less than 25/32 inches.

### 3. Room size requirements

- The room into which refrigerant can leak, plus the connected adjacent room(s) shall have a total area not less than  $A_{min}$  ( $A_{min}$  is shown in Table 2-4).
- The room area in which the unit is installed shall not be less than 20%  $A_{min}$ . ( $A_{min}$  is shown in Table 2-4).

## NOTE

The requirement for the second opening can be met by drop ceilings, ventilation ducts, or similar arrangements that provide an airflow path between the connected rooms.

The minimum opening for natural ventilation ( $Anv_{min}$ ) in connected rooms is related to the room area ( $A$ ), the actual refrigerant charge of refrigerant in the system ( $Mc$ ), and the allowable MAXIMUM REFRIGERANT CHARGE in the system ( $Mmax$ ),  $Anv_{min}$  can be determined according to Table 2-2.

### Minimum opening area for connected rooms

A		Mc		Mmax		Anvmin	
ft <sup>2</sup>	m <sup>2</sup>	lb-oz	kg	lb-oz	kg	ft <sup>2</sup>	m <sup>2</sup>
100	10	17-3	7.8	6-10	3.0	1.3	0.13
110	11	17-3	7.8	7-5	3.3	1.2	0.12
120	12	17-3	7.8	8-0	3.6	1.1	0.11
130	13	17-3	7.8	8-10	3.9	1.0	0.10
140	14	17-3	7.8	9-5	4.2	1.0	0.10
150	14	17-3	7.8	10-0	4.5	0.9	0.09
160	15	17-3	7.8	10-10	4.8	0.8	0.08
170	16	17-3	7.8	11-5	5.1	0.7	0.07
180	17	17-3	7.8	12-0	5.4	0.6	0.06
190	18	17-3	7.8	12-10	5.7	0.5	0.05
200	19	17-3	7.8	13-5	6.0	0.5	0.05
210	20	17-3	7.8	14-0	6.3	0.4	0.04
220	21	17-3	7.8	14-10	6.6	0.3	0.03
230	22	17-3	7.8	15-5	6.9	0.2	0.02
240	23	17-3	7.8	16-0	7.2	0.1	0.01
250	24	17-3	7.8	16-10	7.5	0.1	0.01
260	25	17-3	7.8	17-5	7.8	0.0	0.00

Fig. 2-11 Opening conditions for connected rooms

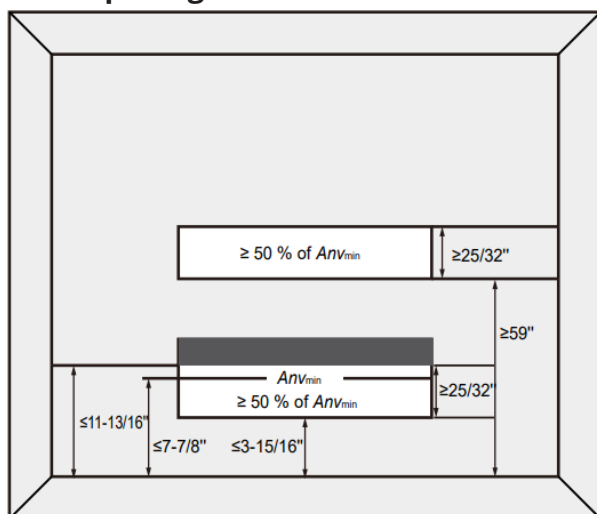

Table 2-2

Note: Take the  $Mc=17lb\ 3oz$  as an example.

For appliances serving two or more rooms with an air duct system, the room area calculation shall be determined based on the total area of the conditioned space ( $TA$ ) connected by ducts taking into consideration that the circulation airflow distributed to all the rooms by the appliance integral indoor fan will mix and dilute the leaking refrigerant before entering any room.

### The Allowed Maximum Refrigerant Charge and Required Minimum Room Area

If the fan incorporated to an appliance is continuously operated or operation is initiated by a refrigerant detection system with a sufficient circulation airflow rate, the allowable maximum refrigerant charge ( $Mmax$ ) and the required minimum room area ( $A_{min}/TA_{min}$ ) is shown in Table 2-3 and Table 2-4.

# 3 AREA LIMITATIONS

**Allowable maximum refrigerant charge**

A/TA		Mmax		A/TA		Mmax	
ft <sup>2</sup>	m <sup>2</sup>	lb-oz	kg	ft <sup>2</sup>	m <sup>2</sup>	lb-oz	kg
60	6	4-0	1.8	170	16	11-5	5.1
70	7	4-10	2.1	180	17	12-0	5.4
80	8	5-5	2.4	190	18	12-10	5.7
90	9	6-0	2.7	200	19	13-5	6.0
100	10	6-10	3.0	210	20	14-0	6.3
110	11	7-5	3.3	220	21	14-10	6.6
120	12	8-0	3.6	230	22	15-5	6.9
130	13	8-10	3.9	240	23	16-0	7.2
140	14	9-5	4.2	250	24	16-10	7.5
150	14	10-0	4.5	260	25	17-5	7.8
160	15	10-10	4.8				

**Table 2-3**

**Required minimum room area**

Mc		Amin/TAmin		Mc		Amin/TAmin	
lb-oz	kg	ft <sup>2</sup>	m <sup>2</sup>	lb-oz	kg	ft <sup>2</sup>	m <sup>2</sup>
3-15	1.8	59.5	5.6	11-0	5.0	165.3	15.4
4-6	2.0	66.1	6.2	11-7	5.2	171.9	16.0
4-13	2.2	72.7	6.8	11-14	5.4	178.5	16.6
5-4	2.4	79.3	7.4	12-5	5.6	185.1	17.2
5-11	2.6	86.0	8.0	12-12	5.8	191.7	17.9
6-2	2.8	92.6	8.7	13-3	6.0	198.4	18.5
6-9	3.0	99.2	9.3	13-10	6.2	205.0	19.1
7-0	3.2	105.8	9.9	14-1	6.4	211.6	19.7
7-7	3.4	112.4	10.5	14-8	6.6	218.2	20.3
7-15	3.6	119.0	11.1	14-15	6.8	224.8	20.9
8-6	3.8	125.6	11.7	15-6	7.0	231.4	21.5
8-13	4.0	132.2	12.3	15-14	7.2	238.0	22.2
9-4	4.2	138.8	12.9	16-5	7.4	244.6	22.8
9-11	4.4	145.5	13.6	16-12	7.6	251.2	23.4
10-2	4.6	152.1	14.2	17-3	7.8	257.9	24.0
10-9	4.8	158.7	14.8				

**Table 2-4**

**Minimum circulation airflow**

Mc		Qmin		Mc		Qmin	
lb-oz	kg	CFM	m <sup>3</sup> /h	lb-oz	kg	CFM	m <sup>3</sup> /h
3-15	1.8	107	182	11-0	5.0	298	506
4-6	2.0	119	202	11-7	5.2	310	527
4-13	2.2	131	223	11-14	5.4	322	547
5-4	2.4	143	243	12-5	5.6	334	567
5-11	2.6	155	263	12-12	5.8	346	588
6-2	2.8	167	284	13-3	6.0	358	608
6-9	3.0	179	304	13-10	6.2	370	629
7-0	3.2	191	325	14-1	6.4	382	649
7-7	3.4	203	345	14-8	6.6	394	669
7-15	3.6	215	365	14-15	6.8	406	690
8-6	3.8	227	386	15-6	7.0	418	710
8-13	4.0	239	406	15-14	7.2	430	731
9-4	4.2	251	426	16-5	7.4	442	751
9-11	4.4	263	447	16-12	7.6	454	771
10-2	4.6	275	467	17-3	7.8	466	792
10-9	4.8	187	488				

**Table 2-5**

The allowable maximum refrigerant charge of the Table 2-3 or the required minimum room area of the Table 2-4 is available only if the following conditions are met:

Minimum velocity of 3.28ft which is calculated as the indoor unit airflow divided by the nominal face area of the outlet. And the grill area shall not be deducted.

Minimum airflow rate must meet the corresponding values in Table 2-5, which is related to the actual refrigerant charge of the system (Mc).

The maximum refrigerant limit described above applies to unventilated areas. If adding additional measures, such as areas with mechanical ventilation or natural ventilation, the maximum refrigerant charge can be increased or the minimum room area can be reduced.

If the actual room area, air outlet height, and refrigerant charge amount are not reflected in the above table, more severe cases need to be considered according to the data in the Tables 2-2, 2-3, 2-4, 2-5.

## Installation scheme flow chart

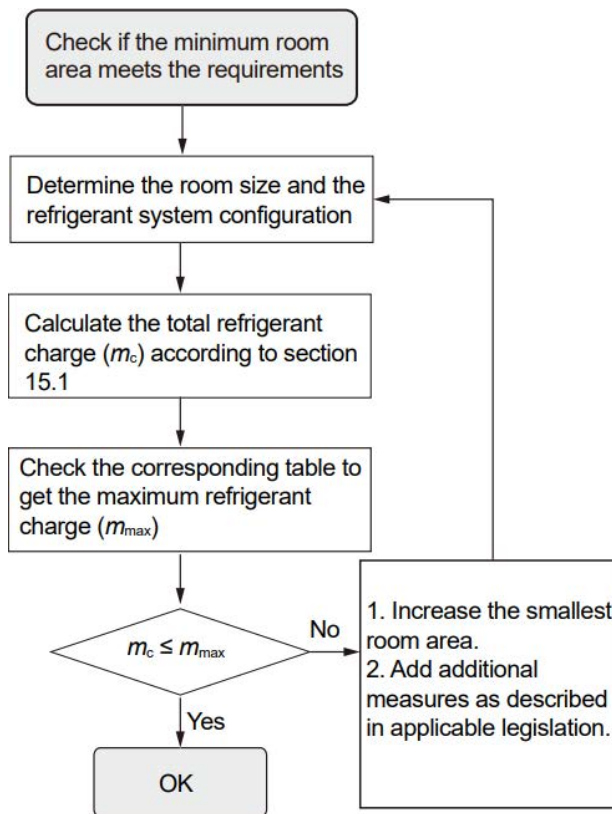

Table 2-12

### 4.1 Refrigerant Sensor

R454B refrigerant leakage sensor is configured for the 3.5 to 5 ton unit. The sensor can only use the factory model or the specified model indicated in the corresponding manual. The sensor must be used to activate the refrigerant shut-off device, the alarm device, incorporated circulation airflow, or other emergency controls which shall give an electrical signal at a predetermined alarm set point in response to leaked refrigerant. The installation of the sensor shall allow access for checking, repair, or replacement by an authorized person. The sensor shall be installed so its function can be verified easily and be protected to prevent tampering or unauthorized resetting of the pre-set value. To be effective, the sensor must be electrically powered at all times after installation other than when servicing. If the sensor detects a refrigerant leak the fan will be turned on to the maximum setting and the compressor and electric heater will stop running. You should immediately leave the area and notify a professional for repair. The System will return to operation if refrigerant is no longer detected in 5 minutes. The service life of the refrigerant sensor is 15 years and should be replaced after the service life. To ensure the detection accuracy of the sensor it is recommended to blow dust off the surface of the sensor after it is used for some time. The operation of the fan can be initiated by the sensor if it meets the incorporated circulation airflow requirements:

The allowed maximum refrigerant charge (Mmax) and the required minimum room area (Amin) can be determined according to Table 2-3 and Table 2-4.



## WARNING

Leak detection system is installed on the unit and must be powered on except for when servicing.

# 5 AIR FLOW PERFORMANCE

Airflow performance is based on cooling performance with a coil and no filter in place. Use this performance table for appropriate unit size, external static applied to unit, and allow operation within the minimum and maximum limits showing in the table for both cooling and electric heat operation.

**Table 3-1 - Indoor Airflow Performance-208 Volts**

Model Number	Motor Speed		External Static Pressure-Inches W.C. [kPa]								
			0[0]	0.1[.02]	0.2[.05]	0.3[.07]	0.4[.10]	0.5[.12]	0.6[.15]	0.7[.17]	0.8[.20]
24	Low-Tap1	SCFM	787	744	691	643	/	/	/	/	/
		Watts	187	185	182	152	/	/	/	/	/
		Amps	0.98	0.77	0.75	0.73	/	/	/	/	/
	Mid-Tap2 (Factory)	SCFM	/	/	/	882	828	751	698	/	/
		Watts	/	/	/	269	262	253	246	/	/
		Amps	/	/	/	1.37	1.34	1.31	1.27	/	/
	High-Tap3	SCFM	/	/	/	/	/	964	896	759	621
		Watts	/	/	/	/	/	360	330	307	276
		Amps	/	/	/	/	/	1.78	1.71	1.64	1.57
30	Low-Tap1	SCFM	911	869	828	782	723	/	/	/	/
		Watts	103	113	122	131	141	/	/	/	/
		Amps	0.9	1.0	1.0	1.1	1.2	/	/	/	/
	Mid-Tap2	SCFM	/	1031	995	961	927	876	829	782	740
		Watts	/	159	170	180	190	203	213	222	230
		Amps	/	1.3	1.4	1.5	1.6	1.7	1.7	1.8	1.9
	High-Tap3 (Factory)	SCFM	/	/	/	/	1079	1050	1015	967	926
		Watts	/	/	/	/	246	257	270	286	297
		Amps	/	/	/	/	2.0	2.1	2.2	2.3	2.4
36	Low-Tap2	SCFM	1073	1031	995	961	927	876	/	/	/
		Watts	148	159	170	180	190	203	/	/	/
		Amps	1.2	1.3	1.4	1.5	1.6	1.7	/	/	/
	Mid-Tap3	SCFM	/	1177	1142	1110	1079	1050	1015	967	926
		Watts	/	209	221	233	246	257	270	286	297
		Amps	/	1.7	1.8	1.9	2.0	2.1	2.2	2.3	2.4
	High-Tap4 (Factory)	SCFM	/	/	/	/	/	1232	1205	1179	1152
		Watts	/	/	/	/	/	347	361	374	386
		Amps	/	/	/	/	/	2.8	2.9	3.0	3.1
42	Low-Tap1 (Factory)	SCFM	1545	1507	1463	1418	1366	1307	1239	1144	/
		Watts	487	479	469	458	447	433	418	400	/
		Amps	2.58	2.55	2.52	2.49	2.46	2.42	2.38	2.33	/
	Mid-Tap2	SCFM	/	/	/	/	1551	1488	1414	1318	1200
		Watts	/	/	/	/	728	712	693	672	644
		Amps	/	/	/	/	4.1	4.05	3.99	3.92	3.84
	High-Tap3	SCFM	/	/	/	/	/	/	1570	1499	1380
		Watts	/	/	/	/	/	/	812	787	759
		Amps	/	/	/	/	/	/	4.57	4.49	4.4

# 5 AIR FLOW PERFORMANCE

Model Number	Motor Speed		External Static Pressure-Inches W.C. [kPa]								
			0[0]	0.1[.02]	0.2[.05]	0.3[.07]	0.4[.10]	0.5[.12]	0.6[.15]	0.7[.17]	0.8[.20]
48	Low -Tap1	SCFM	1545	1507	1463	1418	1366	1307	1239	/	/
		Watts	487	479	469	458	447	433	418	/	/
		Amps	2.58	2.55	2.52	2.49	2.46	2.42	2.38	/	/
	Mid-Tap2 (Factory)	SCFM	1740	1699	1654	1606	1551	1488	1414	1318	1200
		Watts	783	768	756	742	728	712	693	672	644
		Amps	4.27	4.22	4.18	4.14	4.1	4.05	3.99	3.92	3.84
	High-Tap3	SCFM	/	/	/	1800	1740	1671	1595	1499	1380
		Watts	/	/	/	874	854	833	812	787	759
		Amps	/	/	/	4.76	4.7	4.63	4.57	4.49	4.4
60	Low -Tap3 (Factory)	SCFM	1830	1784	1742	1700	1658	1618	1579	1542	1503
		Watts	306	320	336	350	365	380	392	407	420
		Amps	2.4	2.5	2.7	2.8	2.9	3.0	3.1	3.2	3.3
	Mid-Tap4	SCFM	1983	1943	1906	1862	1824	1784	1745	1709	1674
		Watts	391	406	421	438	453	469	486	501	515
		Amps	3.1	3.2	3.3	3.4	3.5	3.6	3.7	3.9	4.0
	High-Tap5	SCFM	2250	2201	2159	2120	2083	2047	2023	1978	1946
		Watts	562	575	593	609	627	645	666	682	700
		Amps	43.	4.4	4.5	4.6	4.7	4.9	5.0	5.1	5.2

**Table 3-2 - Indoor Airflow Performance-230 Volts**

Model Number	Motor Speed		External Static Pressure-Inches W.C. [kPa]								
			0[0]	0.1[.02]	0.2[.05]	0.3[.07]	0.4[.10]	0.5[.12]	0.6[.15]	0.7[.17]	0.8[.20]
24	Low -Tap1	SCFM	885	841	795	743	/	/	/	/	/
		Watts	227	224	221	216	/	/	/	/	/
		Amps	2.07	2.07	2.06	2.05	/	/	/	/	/
	Mid-Tap2 (Factory)	SCFM	/	/	/	988	957	882	767	/	/
		Watts	/	/	/	339	323	307	291	/	/
		Amps	/	/	/	2.31	2.28	2.26	2.24	/	/
	High-Tap3	SCFM	/	/	/	/	/	996	967	928	896
		Watts	/	/	/	/	/	412	392	379	361
		Amps	/	/	/	/	/	2.65	2.57	2.52	2.46
30	Low -Tap1	SCFM	911	869	828	782	723	/	/	/	/
		Watts	103	113	122	131	141	/	/	/	/
		Amps	0.9	1.0	1.0	1.1	1.2	/	/	/	/
	Mid-Tap2	SCFM	/	1031	995	961	927	876	829	782	740
		Watts	/	159	170	180	190	203	213	222	230
		Amps	/	1.3	1.4	1.5	1.6	1.7	1.7	1.8	1.9
	High-Tap3 (Factory)	SCFM	/	/	/	/	1079	1050	1015	967	926
		Watts	/	/	/	/	246	257	270	286	297
		Amps	/	/	/	/	2.0	2.1	2.2	2.3	2.4

# 5 AIR FLOW PERFORMANCE

Model Number	Motor Speed		External Static Pressure-Inches W.C. [kPa]								
			0[0]	0.1[.02]	0.2[.05]	0.3[.07]	0.4[.10]	0.5[.12]	0.6[.15]	0.7[.17]	0.8[.20]
36	Low -Tap2	SCFM	1073	1031	995	961	927	876	/	/	/
		Watts	148	159	170	180	190	203	/	/	/
		Amps	1.2	1.3	1.4	1.5	1.6	1.7	/	/	/
	Mid-Tap3	SCFM	/	1177	1142	1110	1079	1050	1015	967	926
		Watts	/	209	221	233	246	257	270	286	297
		Amps	/	1.7	1.8	1.9	2.0	2.1	2.2	2.3	2.4
	High-Tap4 (Factory)	SCFM	/	/	/	/	/	1232	1205	1178	1152
		Watts	/	/	/	/	/	347	361	374	386
		Amps	/	/	/	/	/	2.8	2.9	3.0	3.1
42	Low -Tap1 (Factory)	SCFM	/	/	/	/	1554	1495	1429	1340	1230
		Watts	/	/	/	/	527	510	469	465	432
		Amps	/	/	/	/	2.29	2.22	2.15	2.02	1.88
	Mid-Tap2	SCFM	/	/	/	/	/	/	/	1503	1384
		Watts	/	/	/	/	/	/	/	566	533
		Amps	/	/	/	/	/	/	/	2.46	2.32
	High-Tap3	SCFM	/	/	/	/	/	/	/	/	1548
		Watts	/	/	/	/	/	/	/	/	662
		Amps	/	/	/	/	/	/	/	/	2.88
48	Low -Tap1	SCFM	1735	1701	1654	1608	1554	1495	1429	1340	/
		Watts	579	573	561	545	527	510	469	465	/
		Amps	2.52	2.49	2.44	2.37	2.29	2.22	2.15	2.02	/
	Mid-Tap2 (Factory)	SCFM	/	/	/	1790	1730	1665	1591	1503	1384
		Watts	/	/	/	658	642	614	592	566	533
		Amps	/	/	/	2.86	2.79	2.67	2.57	2.46	2.32
	High-Tap3	SCFM	/	/	/	/	/	/	1761	1666	1548
		Watts	/	/	/	/	/	/	732	704	662
		Amps	/	/	/	/	/	/	3.18	3.06	2.88
60	Low -Tap3 (Factory)	SCFM	1830	1784	1742	1700	1658	1618	1579	1542	1503
		Watts	306	320	336	350	365	380	392	407	420
		Amps	2.4	2.5	2.7	2.8	2.9	3.0	3.1	3.2	3.3
	Mid-Tap4 (Factory)	SCFM	1983	1943	1906	1862	1824	1784	1745	1709	1674
		Watts	391	406	421	438	453	469	486	501	515
		Amps	3.1	3.2	3.3	3.4	3.5	3.6	3.7	3.9	4.0
	High-Tap5	SCFM	2250	2201	2159	2120	2083	2047	2023	1978	1946
		Watts	562	575	593	609	627	645	666	682	700
		Amps	4.3	4.4	4.5	4.6	4.7	4.9	5.0	5.1	5.2

\* The above airflow data is for reference only.

- The air distribution system has the greatest effect on airflow. The duct system is totally controlled by the contractor. For this reason, the contractor should use only industry-recognized procedures.
- The installers should balance the air distribution system to ensure proper quiet airflow to all rooms in the home. This ensures a comfortable living space.
- Heat pump systems require a specified airflow. Each ton of cooling requires between 300 to 450 cubic feet of air per minute (CFM), or 400 CFM nominally.
- Duct design and construction should be done carefully. System performance can be lowered dramatically due to poor duct design.

# 6 DUCT, CONDENSATE DRAIN, & FILTERS

- Air supply diffusers must be selected and located carefully, they must be sized and positioned to deliver treated air along the perimeter of the space. If they are too small for their intended airflow, they will be noisy. If they are not located properly, they will cause drafts. Return air grilles must be properly sized to carry air back to the blower or they will also cause noise.
- A air velocity meter or air flow hood can give a CFM reading.

## Electric Heater Pressure Drop Tables in i.n.W.C

Installation of a heat kit will cause some pressure drop and the data can be found in the following tables

**Table 3-3 Small Cabinet: 24K, 30K, 36K**

Heater/Pressure Drop	Standard CFM					
	900	1000	1100	1200	1300	1400
5kW	0.05	0.05	0.05	0.05	0.05	0.1
7.5kW	0.05	0.05	0.05	0.05	0.05	0.1
10kW	0.05	0.05	0.05	0.05	0.05	0.1
15kW	/	/	0.1	0.1	0.1	0.1

**Table 3-3 Large Cabinet: 42K, 48K, 60K**

Heater/Pressure Drop	Standard CFM							
	1500	1600	1700	1800	1900	2000	2100	2200
5kW	0.1	0.1	0.1	0.1	0.15	0.15	0.15	0.15
7.5kW	0.1	0.1	0.1	0.1	0.15	0.15	0.15	0.15
10kW	0.1	0.1	0.15	0.15	0.15	0.15	0.15	0.15
15kW	/	/	0.2	0.2	0.2	0.2	0.2	0.2
20Kw	/	/	0.2	0.2	0.2	0.2	0.2	0.25

## 6.1 Ductwork

Ductwork should be made, sized by, and installed and in accordance with the Air Manual from Conditioning Contractors of America and local codes.

### NOTE

- On ductwork exposed to outside air conditioning space, use at least 2" of insulation and a vapor barrier. A Flexible joint may be used to reduce noise.
- A closed return duct system should not preclude the use of economizers or a ventilation intake.



### WARNING

If appliances connected via an air duct system to one or more rooms are installed in a room with an area less than shown in section "Area Limitations" Table 2-4, that room shall be without continuous operating open flames (ex. an operating gas appliance) or other potential ignition sources (for ex. and operating electric heater or hot surfaces). A flame-producing device may be installed in the same space if the device is provided with a effective flame arrest. For appliances connected via an air duct system to one or more rooms, auxiliary devices which may be a potential ignition source shall not be installed in the duct work. Examples of such potential ignitions sources are hot surfaces with a temperature exceeding 1292°F (700°C) and electric switching devices. For appliances connected via an air duct system to one or more rooms, only auxiliary devices approved by the MRCOOL® or declared suitable with the refrigerant shall be installed in the connecting ductwork.

# 6 DUCT, CONDENSATE DRAIN, & FILTERS

## CAUTION

- When fastening duct work to the side flanges on the unit, please insert the screws through the duct flanges only and DO NOT insert the screws through the casing.
- Outdoor duct work must be insulated and waterproofed.

## NOTE

Please refer to Fig. 2-4 and 2-6 for information about supply and return openings.

### 6.2 Condensate Drain

Please consult local codes for special requirements (MRCOOL® will not be responsible for any damages due to the failure to follow these requirements). To provide extra protection from water damage, please install an additional drain pan and drain line (provided by the installer).

#### Installation of Drain Pipe:

1. Use the provided female NPT threaded fitting for the outside connection and make sure that the drain holes are not blocked.
2. Insulation may be needed for the drain line to prevent sweating.
3. The drain pan has two drain connections on each side to provide flexibility of connection and drainage. Make sure proper pitch and plugging if the second connection is not used.
4. Use a sealing compound on the male pipe threads and install the condensate drain line (NPT) to spill into an open drain.
5. Ensure a trap is installed on the condensate drain line.

### 6.3 Filters

Regular cleaning is required for air filters according to MRCOOL® specifications. External filters or other means of filtration is required. Units should be sized for a maximum of 300 feet/min air flow velocity or what is recommended for the type of filter installed. Filter application and placement are critical to airflow, which may affect the heating and cooling system performance. Reduced airflow can shorten the life of the system's major components such as the fan motor, limit switches, heat elements, heat relays, evaporator coil, or the compressor. It is recommended that the return air duct to have only one filter location. For systems with a return air filter grill or multiple filter grills they can have a filter installed at each of the return air openings. If adding high efficiency filters or a electronic air filtration system, it is important that the air flow is not reduced. If the air flow is reduced the overall performance and efficiency of the unit will be reduced. It is recommended that a professional technician is contacted to ensure installation of the air filter and that it is installed properly.

## NOTE

DO NOT double filter the return air duct and DO NOT install a filter in the supply air duct. This will change the performance of the system.  
The air filter must conform with the UL 900 standard.



## WARNING

**DO NOT operate the system without filters. A portion of dust in the air can temporarily lodge in the duct at the supply registers. Any circulated dust particles could be heated and charred by contact with the air handler elements. This residue can soil ceilings, walls, drapes, carpets, and other things in the house. Soot damage can occur with filters in place when certain types of candles, oil lamps, or standing pilots are burned.**

## Air Filter Removal:

1. Remove bolts manually then remove the air filter cover.
2. Hold the edge of the air filter and take out.
3. Clean or change the air filter.
4. Install the new filter so that the arrow on the filter is in the same direction as the airflow.

### 7.1 Power Supply



## WARNING

**Turn off the main electrical power at the branch circuit disconnect closest to the unit before attempting any wiring. Failure to do so can cause electrical shock resulting in personal injury or death.**

1. All wiring should be made in accordance with the National Electrical Code. Consult the local power company to determine the availability of sufficient power to operate the unit. Check the voltage at power supply to make sure it corresponds to the unit's rated voltage requirement. Install a branch circuit disconnect near the rooftop, in accordance with the N.E.C., C.E.C. or local codes.
2. It is important that proper electrical power is available at the unit. Voltage should not vary more than 10% from that stamped on the unit nameplate. On three phase units, phases must be balanced within 3%.
3. If any wire needs to be replaced the replacement wire must be the same type as shown in the nameplate, wiring diagram, and electrical data sheet.
4. Install a branch circuit disconnect of adequate size to the starting current. The disconnect should be located within sight and readily accessible to the unit.
5. ELECTRIC HEATER- If the electric heater is installed the unit may be equipped with a 30A to 60A circuit breaker. These breaker(s) protect the internal wiring in the event of a short circuit and serve as a disconnect.
  - Supply circuit power wiring must be 221°F (105°C) minimum copper conductors only.

See electrical data on the unit for ampacity, wire size, and circuit protector requirements. The supply circuit protective devices can be either fuses or "HACR" type circuit breakers.

- 1-3/8" knockouts inside the cabinet are provided for the connection of power wiring to the electric heater.
- Power wiring is connected to the power terminal block in the units electric cabinet.

### 7.2 Grounding



## WARNING

**The unit must be permanently grounded. Failure to do so may result in electrical shock and cause personal injury or death.**

- The unit must be electrically grounded in accordance with local codes or the national electric code.
- Grounding can be accomplished by attaching ground wire(s) to ground lug(s) provided in the units wiring compartment.

### 7.3 Control Wiring

The thermostat should be mounted on an inside wall about 58in (147cm) from the floor and not be affected by unconditioned air, sun, and/or heat exposure. Follow the instructions carefully as there are many wiring requirements. See Fig. 7-1 and Fig. 7-2.

**Fig. 7-1 Typical Field Control Wiring Diagram**  
UNIT CONTROL BOARD

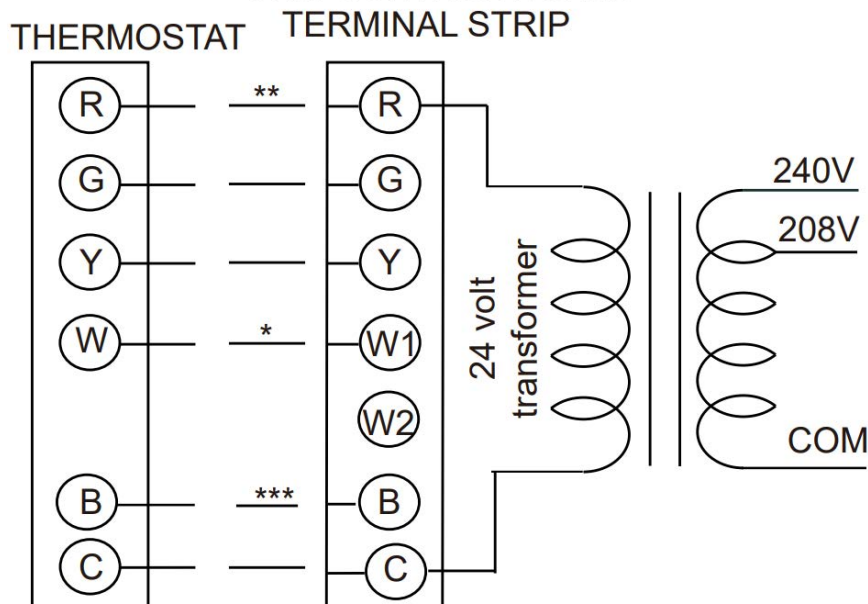

\*\*\* B wire will be used with heat pump system only, the reversing valve energizes in heat mode and cuts off in cooling mode.

\*\* Minimum wire size of 18 AWG wire should be used for all field installed 24V wiring.

\* Only required on units with supplemental electric heat.

## CAUTION

Class 2 low voltage control wiring should not be run in conduit with main power wiring and must be separated from power wiring, unless class 1 wire of proper voltage rating is used.

- Low voltage control wiring should be 18AWG color-coded. For lengths longer than 50ft, 15AWG wire should be used.
- Two 7/8" holes can be used for control wires going into the unit, one on the left side and one at the bottom.
- Make sure after installation the separation of control wiring and power wiring has been maintained.

Label all wire prior to disconnection when servicing controls. Wiring error can cause improper and dangerous operation. Verify proper operation after servicing.

**Fig. 7-2 Typical Field Power Wiring Diagram**

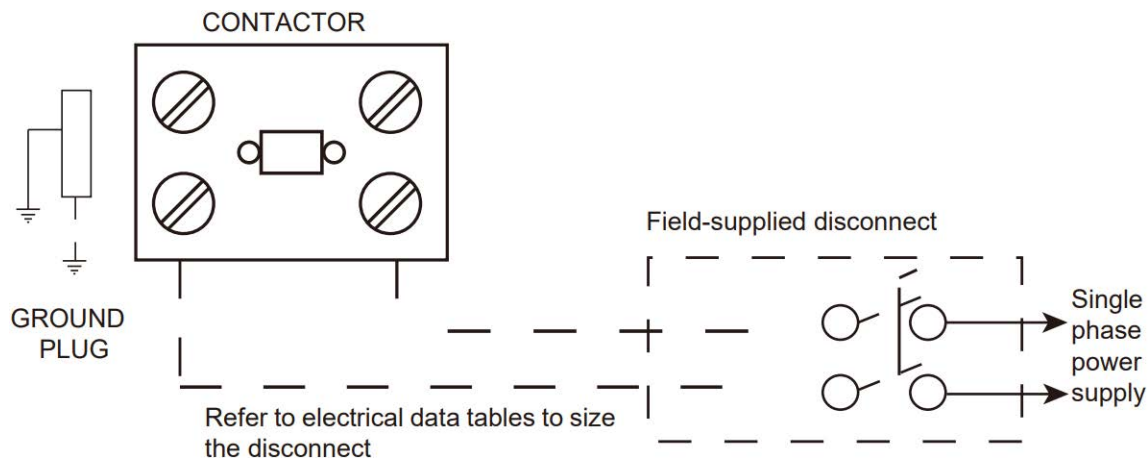

## 8.1 Electric Heater Kit Data

Model Number	Volt	Heater Circuit (without unit)					
		Model	kW	Stages	Amps	MCA (Amps)	Max Fuse Breaker Size (Amps)
24	208/230-1-60	None	-	-	None		
		MHK05PB	3.8/5	1	18.1/20.8	23/26	25/30
		MHK07PB	5.6/7.5	1	27.1/31.3	34/40	35/40
		MHK10PB	7.5/10	1	36.1/41.7	46/53	50/60
30	208/230-1-60	None	-	-	None		
		MHK05PB	3.8/5	1	18.1/20.8	23/26	25/30
		MHK07PB	5.6/7.5	1	27.1/31.3	34/40	35/40
		MHK10PB	7.5/10	1	36.1/41.7	46/53	50/60
		MHK15PB	11.3/15	2	54.2/62.5	68/79	70/80
36	208/230-1-60	None	-	-	None		
		MHK05PB	3.8/5	1	18.1/20.8	23/26	25/30
		MHK07PB	5.6/7.5	1	27.1/31.3	34/40	35/40
		MHK10PB	7.5/10	1	36.1/41.7	46/53	50/60
		MHK15PB	11.3/15	2	54.2/62.5	68/79	70/80
42	208/230-1-60	None	-	-	None		
		MHK05PB	3.8/5	1	18.1/20.8	23/26	25/30
		MHK07PB	5.6/7.5	1	27.1/31.3	34/40	35/40
		MHK10PB	7.5/10	1	36.1/41.7	46/53	50/60
		MHK15PB	11.3/15	2	54.2/62.5	68/79	70/80
		MHK20PB	15/20	2	72.3/83.4	91/105	100/110
48	208/230-1-60	None	-	-	None		
		MHK05PB	3.8/5	1	18.1/20.8	23/26	25/30
		MHK07PB	5.6/7.5	1	27.1/31.3	34/40	35/40
		MHK10PB	7.5/10	1	36.1/41.7	46/53	50/60
		MHK15PB	11.3/15	2	54.2/62.5	68/79	70/80
		MHK20PB	15/20	2	72.3/83.4	91/105	100/110
60	208/230-1-60	None	-	-	None		
		MHK05PB	3.8/5	1	18.1/20.8	23/26	25/30
		MHK07PB	5.6/7.5	1	27.1/31.3	34/40	35/40
		MHK10PB	7.5/10	1	36.1/41.7	46/53	50/60
		MHK15PB	11.3/15	2	54.2/62.5	68/79	70/80
		MHK20PB	15/20	2	72.3/83.4	91/105	100/110

1. Minimum Circuit Ampacity.
2. Maximum Over Current Protection per Standard UL 60335.
3. Fuse or HACR circuit breaker size installed at factor or field installed.

## 8.2 Electric Heater Kit Information

Installation of electric heat must conform with standard National Fire Protection Association (NFPA) Standard for Installation of Air Conditioning and Ventilation Systems NFPA No. 90A, Standard for the Installation of Residence Type Warm Air Heating and Air Conditioning System NFPA No. 90B, MRCOOL® installation instructions and local municipal building codes. Heaters are approved for clearance to combustible materials as listed on heater rating plate. Accessibility and service clearances must take precedence over fire protection clearances. All wiring must conform with local codes and the National Electric Code (NEC). ANSI-C1-1978.

### CAUTION

As with any mechanical equipment, contact with sharp sheet metal edges can result in personal injury. Take care while handling this equipment and wear gloves and protective clothing. The circuit breaker of the electric heater kit in the unit cannot be used as a air switch for power cables and cannot be operated by users. Maintenance personnel need to disconnect the main switch before servicing. If installing a third-party electric heater kit, ensure that all components used of the electric heater kit meet the A2L flammable refrigerant regulations.



### WARNING

**Supply circuit power wiring must be 167°F (75°C) minimum copper conductors only. See Table 9-3 for Electrical Data in this section for ampacity, wire size and circuit protector requirement. Supply circuit protective devices may be either fused or "HACR" type breakers.**

### NOTE

Please refer to the manual of electric heater kit for detailed installation and wiring instructions. Heat pump systems require a specified airflow. Each ton of cooling requires between 350 to 450 cubic feet of air per minute (CFM), or 400 CFM nominally.

## 9.1 Compressor Crankcase heater

Refrigerant migration during the OFF cycle can result in noisy start-ups, therefore a Crankcase Heater (CCH) is used to minimize refrigerant migration thereby minimizing start-up noise and/or bearing "wash out". All CCHs must be installed on the lower half of the compressor shell. Its purpose is to warm the compressor during the OFF cycle, driving refrigerant from the compressor. After extended shutdown periods in cold weather, it is recommended to allow CCH to be energized for at least 12h prior to compressor operation by applying line voltage to the system with the thermostat OFF.

The crankcase heater start must meet two conditions:

- A. Outdoor temperature < 41°F (5°C)
- B. At power up or if the compressor has been off for more than 3h.

The crankcase heater stop must meet the following condition:

- Outdoor temperature ≥ 45°F (7°C) or compressor starts.

## 9.2 Reversing Valve

The reversing valve energizes in heat mode and cuts off in cool mode.

## 9.3 Wind Pressure Switch

The wind pressure switch detects the pressure difference between the wind wheel and the electronic control chamber to determine whether the indoor airflow meets the requirements of the electrical heater. If indoor airflow is below the range required in Table 3-1 and Table 3-2, the pressure difference between two sides of the wind pressure switch may be lower than the limit value, and the wind pressure switch will cut off making the electrical heater stop working.

If indoor airflow meets the requirements but the electrical heater stops working, the steps below should be checked:

1. The signal cables of the wind pressure switch are disconnected.
2. Connection pipe of the wind pressure switch is bent or blocked.
3. The wind pressure switch is damaged.

### CAUTION

The wind pressure switch can only be the factory model.

#### 9.4 Protection Function

- T3 = Outdoor Coil Temperature:  
T3 > 143.6°F (62°C), compressor stops working  
T3 < 125.6°F (53°C), compressor restarts
- T4 = Ambient Temperature:  
T4 < 0°F (-18°C), compressor can't start  
T4 > 5°F (-15°C), compressor restarts  
If 32°F (0°C) ≤ T4 ≤ 120°F (49°C), the unit can operate in cooling  
If 0°F (-18°C) ≤ T4 ≤ 75°F (24°C), the unit can operate in heating

### NOTE

When T4 < 0°F (-18°C), the outdoor unit would provide a signal to drive up the heater installed in the indoor unit.

- Discharge Temperature Protection:  
Discharge temperature > 239°F (115°C), the compressor stops working  
Discharge temperature < 167°F (75°C), the compressor restarts

### NOTE

In stand-by status, the compressor will not start in Discharge Temperature Protection. Within 1h, if 5 protection cycles occur the system will be locked out for 30 minutes. If this situation occurs 4 times in 3 days, the system will be locked out. It will restore after a power cycle.

- High Pressure Protection:  
High pressure > 580 psig, the compressor and outdoor fan motor stop working.  
High pressure < 435 psig, the compressor and outdoor fan motor restart (3 minute delay necessary)
- Low Pressure Protection:  
Low pressure < 15 psig, the compressor and outdoor fan motor stop working  
Low pressure > 32 psig, the compressor and outdoor fan motor restart (3 minute delay necessary)

### NOTE

In stand-by status, the compressor will not start in low pressure protection. Within 30 minutes, if 4 protection cycles occur, the system will be locked out. It will restore after a power cycle.

## 9.5 LED Status

Indicator Light Description:

The module board has an indicator light, LED1 (RED), which indicates the motor status.

1. When powered on, the LED 1 light will be on for 3s first, then the software version number is displayed. The number of times the LED 1 light flashes represents the software version number value.
2. When in standby mode, the LED 1 light flashes slowly at 4Hz, lights up for 2s, and turns off for 2s.
3. When running, the LED 1 light is always on.
4. When a fault occurs: the LED 1 light flashes. The flashing LED 1 light flashes with the fault category number as the number of times, then stops for 3s, and keeps cycling until the fault state is cleared. The shortest fault display is 60s or the restart is successful. The flashing cycle is 800ms.
5. When a communication fault occurs, the LED 1 flashes quickly with a cycle of 400ms until the communication is restored.

## 9.6 Defrost Mode

Manual Defrost Mode

When the button "Force" is pressed for 6s, the system turns to the defrost mode. The defrost mode exits by the logic of shut-down conditions of defrost mode.

# 10 TEMPERATURE SENSOR RESISTANCE TABLE

Table 9-1

Temperature °F	Resistance kΩ	Temperature °F	Resistance kΩ	Temperature °F	Resistance kΩ	Temperature °F	Resistance kΩ
-4	106.73	37	29.87	78	10	119	3.69
-3	103.25	38	29.22	79	9.5	120	3.61
-2	99.89	39	28.19	80	9.26	121	3.53
-1	96.65	40	27.39	81	9.03	122	3.45
0	93.53	41	26.61	82	8.81	123	3.38
1	90.53	42	25.85	83	8.59	124	3.3
2	87.62	43	25.12	84	8.38	125	3.26
3	84.83	44	24.42	85	8.17	126	3.16
4	82.13	45	23.73	86	7.97	127	3.1
5	79.52	46	23.07	87	7.78	128	3.03
6	770.1	47	22.42	88	7.59	129	2.96
7	74.58	48	21.8	89	7.4	130	2.9
8	72.24	49	21.2	90	7.22	131	2.84
9	69.98	50	20.61	91	7.05	132	2.78
10	67.8	51	20.04	92	6.88	133	2.72
11	65.69	52	19.49	93	6.72	134	2.67
12	63.65	53	18.96	94	6.56	135	2.61
13	61.68	54	18.44	95	6.4	136	2.56
14	59.78	55	17.94	96	6.25	137	2.5
15	57.95	56	17.45	97	6.1	138	2.45
16	56.17	57	16.98	98	5.96	139	2.4
17	54.46	58	16.52	99	5.82	140	2.35
18	52.8	59	16.08	100	5.68	141	2.3
19	51.2	60	15.65	101	5.55	142	2.25
20	49.65	61	15.23	102	5.42	143	2.21
21	48.16	62	14.83	103	5.3	144	2.16
22	46.71	63	14.43	104	5.18	145	2.12
23	45.31	64	14.05	105	5.06	146	2.08
24	43.95	65	13.68	106	4.94	147	2.03
25	42.64	66	13.32	107	4.83	148	1.99
26	41.38	67	12.97	108	4.72	149	1.95
27	40.15	68	12.64	109	4.61	150	1.91
28	38.97	69	12.31	110	4.51	151	1.88
29	37.82	70	11.99	111	4.41	152	1.84
30	36.71	71	11.68	112	4.31	153	1.8
31	35.64	72	11.38	113	4.21	154	1.77
32	34.6	73	11.09	114	4.12	155	1.73
33	33.59	74	10.8	115	4.03	156	1.7
34	32.61	75	10.53	116	3.94	157	1.66
35	31.67	76	10	117	3.85	158	1.63
36	30.76	77	10	118	3.77	159	1.6

# 11 Thermostat Signals

**Table 9-2: Thermostat Signals**

Signal	State	Board Function
G	ON	Blower instant ON
	OFF	24/30/36/60K: blower 90s delay OFF 42/48K: blower delay OFF according to wiring diagram
G & W1	ON	Blower instant ON Heater bank 1 elec. constant ON
	OFF	Heater bank 1 elec instant OFF 24/30/36/60K: blower 90s delay OFF 42/48K: blower delay OFF according to wiring diagram
G & W & W2	ON	Blower instant ON Heater 1 instant ON Heater 2 instant ON
	OFF	24/30/36/60K: blower 90s delay OFF 42/48K: blower delay OFF according to wiring diagram Heater 1 instant OFF Heater 2 instant OFF
G & Y	ON	Blower instant ON Compressor and outdoor fan instant ON
	OFF	Compressor and outdoor fan instant OFF 24/30/36/60K: blower 90s delay OFF 42/48K: blower delay OFF according to wiring diagram
G & B & Y	ON	4-way valve instant ON Blower instant ON Compressor and outdoor fan instant ON
	OFF	Compressor and outdoor fan instant OFF 24/30/36/60K: blower 90s delay OFF 42/48K: blower delay OFF according to wiring diagram 4-way valve instant OFF
G & B & Y & W1 & W2	ON	4-way valve instant ON Blower instant ON Compressor and outdoor fan instant ON Heater 1 instant ON Heater 2 instant ON
	OFF	4-way valve instant OFF 24/30/36/60K: blower delay OFF according to wiring diagram Compressor and outdoor fan instant OFF Heater 1 instant OFF Heater 2 instant OFF

**Table 9-3: Thermostat Wire Color**

Thermostat Wire Color	Function
Red	Power wire
Black	Power wire
White	Heater signal 1
Green	Blower fan signal
Yellow	Compressor signal
Blue	Reversing valve signal
Brown	Heater signal 2

## 12.1 Operation Check-Up

- **Cooling Startup**

1. Turn the thermostat to OFF and turn power to ON.
2. Turn ON thermostat and set as high as possible.
3. Turn fan switch ON and indoor blower should run.
4. Turn fan switch to AUTO, system switch to COOL and thermostat temperature setting below room temperature. (Unit should run in cooling mode).

- **Heating Startup**

- After normal cooling run

1. Turn the thermostat switch to HEAT. After unit stops, wait about 5 minutes.
2. Turn thermostat setting above room temperature. Unit should run in HEATING mode.  
After the unit has run for awhile, check the following:
  - Are fans running properly?
  - Is compressor running correctly?
  - Check refrigerant charge.
  - Check duct connection for leaks.
  - Check for tubing and sheet metal rattles.
  - (See Wiring Diagram for electric connection details).

## 12.2 Error Code & Troubleshooting



### WARNING

Component troubleshooting requires opening the control box with the power ON. Use extreme care when working in these conditions. Check the nameplate and the instructions when making wire connections.

Table 11-1

Code	Description	Possible Reason
E3	T3 sensor fault	T3 sensor is short circuit or open circuit
E4	T4 sensor fault	T4 sensor is short circuit or open circuit
E8	Capacity setting not set	Capacity setting (SW2) isn't set/ Program error
E9	R110 resistor or drive chip software fault	Fan has failed/Outdoor control board has failed
P2	LPC protection	Poor heat exchange on evaporation side/LPC fault/Charging leakage (low refrigerant)/piston blocked
P4	Discharge temperature protection	High temperature and overload/ Throttle blockage/Charging leakage (low refrigerant)/DTS failure
P5	T3 high-temperature protection	High temperature and overload/ Poor-heat exchange on condensing side/T3 failure
AL	Ambient temperature limitation	Ambient temperature is out of range/There are other heat sources around T4
H0	Communication fault between drive chip and main control chip	Program error/Outdoor control board has failed
n2X-n6X	Fan drive fault	Wiring error/Fan failure

## 12.3 Error Code of Control Board

The unit LED will flash when the unit is abnormal. Security consideration, the outdoor unit will shutdown until the abnormal condition is corrected.

**Table 11-2**

No.	LED1 Status	Description	Possible Reason
1	3Flash/Cycle	R454B refrigerant sensor fault	R454B refrigerant sensor failure
2	4Flash/Cycle	R454B Refrigerant sensor communication fault	Wiring error/R454B refrigerant sensor failure
3	Keeps Flashing	R454B refrigerant leakage protection in indoor unit	R454B refrigerant leakage/R454B refrigerant sensor failure
4	8Flash/Cycle	R454B refrigerant sensor over service life	R454B refrigerant sensor over service life/R454B refrigerant sensor failure

### NOTE

The flash interval is 2s. For example: 3 flash/cycle is a flash three times every 2s.

### CAUTION

If the refrigerant sensor is over service life, it should be replaced by an authorized person. If a leak is detected, follow safety procedures: Immediately evacuate everyone from the room or space and contact a qualified licensed service personnel to advise them that the refrigerant R454B (A2L) flammable refrigerant leak has occurred.



## 12.5 Status Code

Code	Description
--	Standby
-C	Cooling mode
-H	Heating mode
FC	Forced cooling mode
dF	Defrosting mode
CH	Abnormal signal

**Table 11-4**

## 12.6 Parameter Point Check Table

To display system parameters, press the "Check" button to index through the series of parameters available. The first time you press the "Check" button, it will display the sequence, and after 1s it will display the value of the parameter. If you press the "Check" button again it will display the next sequence.

After 30s on the same parameter, the display will revert back to normal status.

**Table 11-5**

No.	Point Check Content
1	Unit capacity
2	Operation mode
3	Current fan speed (Actual speed divided by 10, 560R is represented by "56", 1050R is represented by "A5")
4	Target fan speed (Actual speed divided by 10, for example, 560R is represented by "56", 1050R is represented by "A5")
5	T3 temperature (°F) (If the value is less than 100, the actual value is displayed. If over 100, divide by 10, 135 is represented by "13", if it is negative, "1.0" means -10, ".5" means -5)
6	T4 temperature (°F) (If the value is less than 100, the actual value is displayed. If over 100, divide by 10, 135 is represented by "13", if it is negative, "1.0" means -10, ".5" means -5)
7	Compressor running time (day) (If the value is less than 100, the actual number of days is displayed. If over 100 and less than 10000, 360 days are represented by "36", if over 1000, 3600 days are represented by "3.6")
8	Main control chip software version
9	Drive chip software version
10	Y1 signal state (1=ON, 0=OFF)
11	B signal state (1=ON, 0=OFF)
12	W signal state (1=ON, 0=OFF)
13	Y2 signal state (1=ON, 0=OFF)
14	RV condition (1=ON, 0=OFF)
15	High wind pattern (1=ON, 0=OFF)
16	Last fault code
17	Last second fault code
18	Last third fault code
19	--

# 13 WIRING DIAGRAM

## HP System Wiring Diagram (24/30/36K)

**WARNING: HAZARDOUS VOLTAGE. DISCONNECT ALL ELECTRIC POWER INCLUDING REMOTE DISCONNECTS BEFORE SERVICING. INSURE THAT ALL CAPACITORS HAVE DISCHARGED STORED VOLTAGE.**

**NOTICE:**  
1. B terminal is connected and energized for heating operation.  
2. W terminal is energized in defrosting operation.

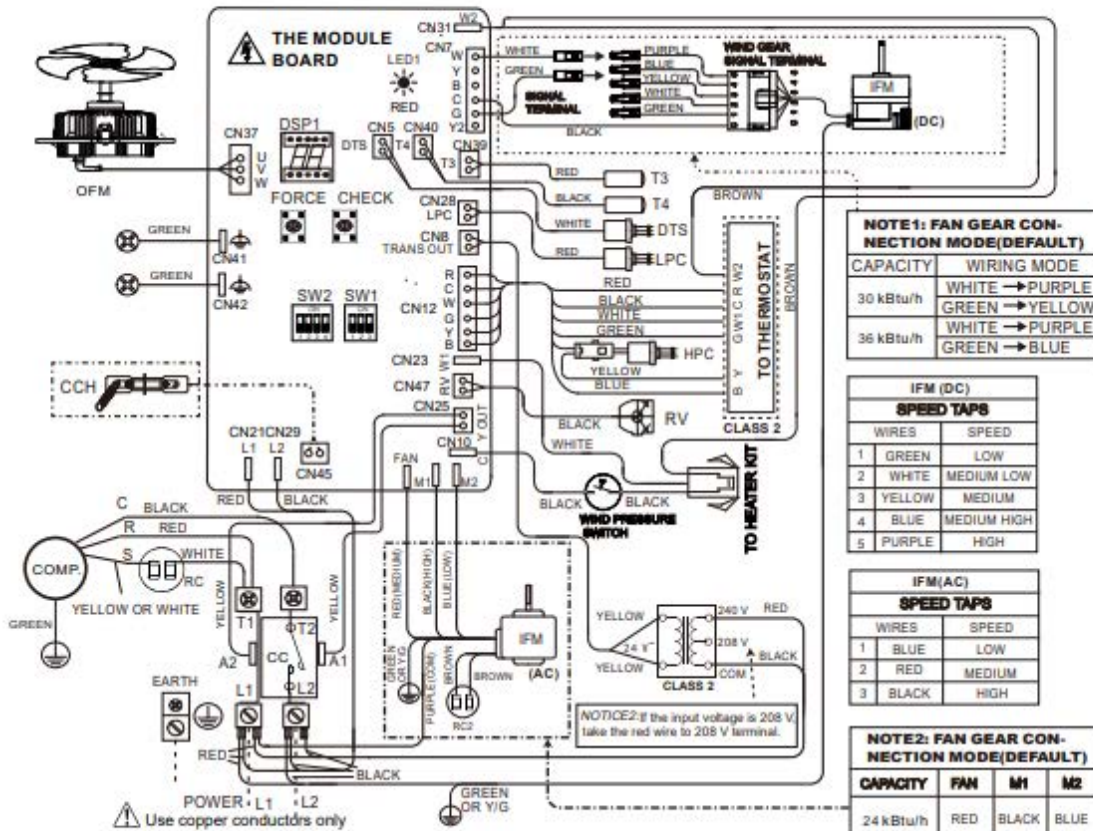

**NOTE1: FAN GEAR CONNECTION MODE(DEFAULT)**

CAPACITY	WIRING MODE
30 kBTU/h	WHITE → PURPLE GREEN → YELLOW
36 kBTU/h	WHITE → PURPLE GREEN → BLUE

**IFM (DC) SPEED TAPS**

WIRES	SPEED
1 GREEN	LOW
2 WHITE	MEDIUM LOW
3 YELLOW	MEDIUM
4 BLUE	MEDIUM HIGH
5 PURPLE	HIGH

**IFM (AC) SPEED TAPS**

WIRES	SPEED
1 BLUE	LOW
2 RED	MEDIUM
3 BLACK	HIGH

**NOTE2: FAN GEAR CONNECTION MODE(DEFAULT)**

CAPACITY	FAN	M1	M2
24 kBTU/h	RED	BLACK	BLUE

CODE	FAULT DESCRIPTION
E3	T3 sensor fault
E4	T4 sensor fault
E8	Capacity setting no set
E9	R110 resistor or drive chip software fault
P2	LPC protection
P4	Discharge temperature protection
P5	T3 high-temperature protection
AL	Ambient temperature limitation
H0	Communication fault between drive chip and main control chip
n1X	OFM overcurrent protection
n2X	Drive module overtemperature protection
n3X	DC bus voltage fault
n4X	IFM Fault
n5X	OFM startup fault
n6X	Phase loss protection

"n" serial faults, alternately display n and xx

NUMBER	POINT CHECK CONTENT
1	Unit capacity
2	Operation mode
3	Current fan speed(Actual speed divided by 10, for example, 56DR is represented by '56.', 1050R is represented by 'A5.', hexadecimal number A represents 10.)
4	Target fan speed(Target speed divided by 10, for example, 56DR is represented by '56.', 1050R is represented by 'A5.', hexadecimal number A represents 10.)
5	T3 temperature("F")(if the value is less than 100, the actual value is displayed. If over 100, divided by 10, 135 is represented by '13.'. If it is negative, '1.0' means -10, '1.5' means -5)
6	T4 temperature("F")(if the value is less than 100, the actual value is displayed. If over 100, divided by 10, 135 is represented by '13.'. If it is negative, '1.0' means -10, '1.5' means -5)
7	Compressor running time(day) (if the value is less than 100, the actual number of days is displayed. If over 100 and less than 1000, 360 days are represented by '36.', if over 1000, 3600 days are represented by '3.6.')
8	Main control chip software version
9	Drive chip software version
10	Y signal state(1=ON, 0=OFF)
11	B signal state(1=ON, 0=OFF)
12	W1 signal state(1=ON, 0=OFF)
13	W2 signal state(1=ON, 0=OFF)
14	RV(4-Way Valve) condition (1=ON, 0=OFF)
15	High fan speed mode (1=ON, 0=OFF)
16	Last fault code
17	Last second fault code
18	Last third fault code
19	--

SW1	SW1-1	ON	13.4HP package(only used for replacing board)
	SW1-1	ON	Reserved
	SW1-2	ON	Reserved
	SW1-3	ON	Reserved
	SW1-1	OFF	Reserved
	SW1-2	OFF	Reserved
	SW1-3	OFF	Reserved
	SW1-1	ON	Defrosting cycle:30 min
	SW1-2	ON	Defrosting cycle:30 min
	SW1-3	ON	Defrosting cycle:30 min
	SW1-1	OFF	Defrosting cycle:60 min
	SW1-2	OFF	Defrosting cycle:60 min
	SW1-3	OFF	Defrosting cycle:60 min

CAPACITY SETTING	MODEL	24 kBTU/h	30 kBTU/h	36 kBTU/h	SW2 - 4 definition
13.4 HP	001,1	2 TON	2.5 TON	3 TON	100 W Fan motor
	010,1	42 kBTU/h	48 kBTU/h	60 kBTU/h	200 W Fan motor
	100,1	3.5 TON	4 TON	5 TON	200 W Fan motor

MODEL	DESCRIPTION
13.4 HP	13.4 SEER heat exchanger package unit

CODE	DESCRIPTION
CC	Compressor Contactor
COMP.	Compressor
CCH	Crankcase Heater
T4	Ambient Temperature Sensor
T3	Pipe Temperature Sensor
HPC	High Pressure Cut-out Control
LPC	Low Pressure Cut-out Control
DTS	Discharge Temperature Switch
OFM	Outdoor Fan Motor
IFM	Indoor Fan Motor
RC	Run Capacitor
RV	Reversing Valve

0/1 DEFINITION OF DIP SWITCH	CODE	DESCRIPTION
means 0=OFF	--	Standby
	-C	Cooling mode
	-H	Heating mode
	FC	Forced cooling mode
	dF	Defrosting mode
	CH	Abnormal signal

Force	Press 1 s	Forced cooling mode
	Press 6 s	Forced defrosting mode
Check	Press 1 s	Check the system parameters

Hazardous voltage line  
- Factory standard  
- Field installed  
- Factory optional

Extra-low-voltage line  
- Factory standard  
- Factory optional

**WARNING!**  
Cabinet must be permanently earthed, and all wiring conform to UL60335. Replacement wires must be the same gauge and insulation type as original wires.

THE WIRING DIAGRAM SHOWN IS FOR REFERENCE ONLY. IT MAYBE DIFFERENT FROM THE ACTUAL PRODUCT.



# 13 WIRING DIAGRAM

## HP System Wiring Diagram (60K)

**WARNING: HAZARDOUS VOLTAGE. DISCONNECT ALL ELECTRIC POWER INCLUDING REMOTE DISCONNECTS BEFORE SERVICING. INSURE THAT ALL CAPACITORS HAVE DISCHARGED STORED VOLTAGE.**

FOR REFRIGERANT LEAK PROTECTION  
**LEAK ALARM DEVICE**

**NOTICE 1:**  
1. B terminal is connected and energized for heating operation.  
2. W terminal is energized in defrosting operation.

**CODE FAULT DESCRIPTION**

E3	T3 sensor fault
E4	T4 sensor fault
E8	Capacity setting no set
E9	R110 resistor or drive chip software fault
P2	LPC protection
P4	Discharge temperature protection
P5	T3 high-temperature protection
AL	Ambient temperature limitation
H0	Communication fault between drive chip and main control chip
n1X	OFM overcurrent protection
n2X	Drive module overtemperature protection
n3X	DC bus voltage fault
n4X	IPM Fault
n5X	OFM startup fault
n6X	Phase loss protection
"n" serial faults, alternately display n and xx	

**SPEED TAPS**

LOW	MEDIUM LOW
MEDIUM	MEDIUM HIGH
HIGH	

Hazardous voltage line  
- Factory standard  
- Field installed  
- Factory optional

Extra-low-voltage line  
- Factory standard  
- Factory optional

**0/1 DEFINITION OF DIP SWITCH**

<input type="checkbox"/>	means 0=OFF	<input type="checkbox"/>	means 1=ON
--------------------------	-------------	--------------------------	------------

**SETTING INSTRUCTIONS**

**1-STAGE CONTROLLER**

DIP SWITCH	Y1 OR G	W1/W2
<input type="checkbox"/>	2	3
<input type="checkbox"/>	3	4
<input type="checkbox"/>	4	5
<input type="checkbox"/>	5	5

**NOT USED**

SW6-3,4 **FACTORY DEFAULT**

SW7-1,2 **FACTORY DEFAULT**

SW7-3,4 **FACTORY DEFAULT**

**CAPACITY SETTING**

MODEL	24 kBTu/h 3 TON	30 kBTu/h 2.5 TON	36 kBTu/h 3 TON
SW2	501.1	010.1	010.1
SW2	42 kBTu/h 3.5 TON	48 kBTu/h 4 TON	60 kBTu/h 5 TON
HP	100.1	100.1	100.1

**SW2 - 4 definition**

<input type="checkbox"/>	100 W	<input type="checkbox"/>	200 W
<input type="checkbox"/>	Fan motor	<input type="checkbox"/>	Fan motor

**SW1**

SW1-1	ON	13.4HP package (only used for replacing board)
SW1-1	OFF	Reserved
SW1-2	ON	Reserved
SW1-2	OFF	Reserved
SW1-3	ON	Defrosting cycle: 30 min
SW1-3	OFF	Defrosting cycle: 60 min

**MODEL DESCRIPTION**

13.4 HP	13.4 SEER heat exchanger package unit
---------	---------------------------------------

**LED 1(GREEN) STATUS CONTENT**

LED STATUS	CONTENT
STEADY ON	Normal Operation
OFF	Power Supply Fault
KEEP FLASHING	Refrigerant Leak Protection
3 FLASH CYCLE	R454B Refrigerant Sensor Fault
4 FLASH CYCLE	R454B Refrigerant Sensor Communication Fault
8 FLASH CYCLE	R454B Refrigerant Sensor Over Service Life

**CODE DESCRIPTION**

--	Standby
-C	Cooling mode
-H	Heating mode
FC	Forced cooling mode
dF	Defrosting mode
CH	Abnormal signal

**CODE DESCRIPTION**

CC	Compressor Contactor
COMP.	Compressor
CCH	Crankcase Heater
T4	Ambient Temperature Sensor
T3	Pipe Temperature Sensor
HPC	High Pressure Cut-out Control
LPC	Low Pressure Cut-out Control
DTS	Discharge Temperature Switch
OFM	Outdoor Fan Motor
RC	Run Capacitor
RV	Reversing Valve
IFM	Indoor Fan Motor

**Force** Press 1 s Forced cooling mode  
Press 6 s Forced defrosting mode

**Check** Press 1 s Check the system parameters

**NOTICES:**

- 1: If connected to the 1-Stage controller, please short the signals Y1 and Y2.
- 2: Connect R to R, G to G, Y to Y, etc. See outdoor instruction for details.
- 3: If some signal lines of CN36 are not used, please wrap them up separately with CAP.

**CAUTION:**

- 1: Use copper wire (75 °C min.) only between disconnect switch and unit.
- 2: To be wired in accordance with NEC and local codes.
- 3: If any of the original wires, as supplied, must be replaced. Use the same or equivalent type wires.
- 4: If the input voltage is 208 V, please change the transformer tap by taking the red wire to 208 V terminal.
- 5: The rated output operating condition of CN34 is 24 VAC/1A or 30 VDC/1A or 250 VAC/1A. Please refer to the manual for wiring methods.

**WARNING!**  
Cabinet must be permanently earthed and all wiring conform to UL60335. Replacement wires must be the same gauge and insulation type as original wires.

**NUMBER POINT CHECK CONTENT**

1	Unit capacity
2	Operation mode
3	Current fan speed/Actual speed divided by 10, for example, 560R is represented by '56.', 1050R is represented by 'A5.', hexadecimal number A represents 10.
4	Target fan speed/Target speed divided by 10, for example, 560R is represented by '56.', 1050R is represented by 'A5.', hexadecimal number A represents 10.
5	T3 temperature("F") if the value is less than 100, the actual value is displayed. If over 100, divided by 10, 135 is represented by '13.', if it is negative, '1.0' means -10, '1.5' means -5.
6	T4 temperature("F") if the value is less than 100, the actual value is displayed. If over 100, divided by 10, 135 is represented by '13.', if it is negative, '1.0' means -10, '1.5' means -5.
7	Compressor running time(day) (if the value is less than 100, the actual number of days is displayed. If over 100 and less than 1000, 360 days are represented by '36.', if over 1000, 3600 days are represented by '3.6.')
8	Main control chip software version
9	Drive chip software version
10	Y1 signal state(1=ON, 0=OFF)
11	B signal state(1=ON, 0=OFF)
12	W1 signal state(1=ON, 0=OFF)
13	W2 signal state(1=ON, 0=OFF)
14	Y2 signal state(1=ON, 0=OFF)
15	RV(4-Way Valve) condition (1=ON, 0=OFF)
16	High fan speed mode (1=ON, 0=OFF)
17	Last fault code
18	Last second fault code
19	Last third fault code

**Factory code Date Revision**

1602770003455	Sep. 28th, 2024	B
---------------	-----------------	---

THE WIRING DIAGRAM SHOWN IS FOR REFERENCE ONLY. IT MAYBE DIFFERENT FROM THE ACTUAL PRODUCT.

41

mrcool.com

Comply with national regulations.

Components and accessories from the units are not part of ordinary domestic waste.

Complete units, compressors, motors, etc. are only to be disposed of via qualified disposal specialists.

This unit uses flammable refrigerant R454B. Please contact a qualified person when you want to dispose of the unit. Law requires that the collection, transportation, and disposal of refrigerant must conform with the regulations governing the collection and destruction of hydrofluorcarbons.



**MRCOOL®**  
COMFORT MADE SIMPLE

**VersaPro®**  
**Packaged Heat Pump**  
Installation Manual

The design and specifications of this product and/or manual are subject to change without prior notice.  
Consult with the sales agency or manufacturer for details.