

BG-101

INSTRUCTIONS

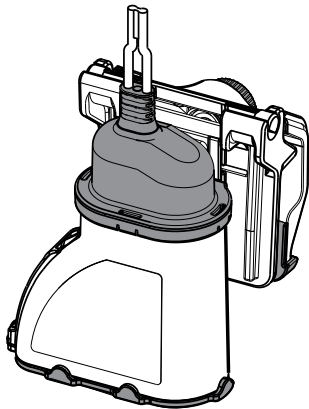

SECONDARY PAN SENSOR FOR METAL & PLASTIC PANS

⚠️ WARNING: WORK SAFE, READ THIS!

FAILURE TO READ AND COMPLY WITH ALL WARNINGS, CAUTIONS, INSTRUCTIONS PRIOR TO STARTING INSTALLATION MAY CAUSE PERSONAL INJURY AND/OR PROPERTY DAMAGE AND VOID WARRANTY.

This device must be installed in accordance with manufacturer's instructions. This installation must be in accordance with all applicable local plumbing, drainage, and electrical codes.

This device must be installed in accordance with manufacturer's instructions. This installation must be in accordance with all applicable local plumbing, drainage, and electrical codes.

Remove electric shock hazard — DISCONNECT THE POWER BEFORE INSTALLING SWITCH to avoid electrical shock and/or equipment damage. Do not use on circuits exceeding 24 volts to avoid damage to switch, shock, or fire hazard. Switch must be connected to an isolated transformer with a max rating of 30VAC, 8A, and 100VA.

In any installation where property damage might result from inoperative switch due to a power outage, back-up system(s) and/or alarm should be installed.

The switch must only be installed by a licensed contractor or under the direct supervision of same. The condensation pan must be properly maintained after installation and remain free from foreign objects, rust, or other obstructions that might interfere with the proper operation of the float switch.

INSTALL FLOAT SWITCH ON DRAIN PAN
(To ensure proper performance of product, instructions must be followed.)

1. Disconnect power to unit at main panel.
2. Disconnect power to the low voltage thermostat circuit.
3. Slide the float switch onto the side of the pan.
4. Lightly secure the float switch by tightening the thumb screws (Fig.1). Do not over tighten.

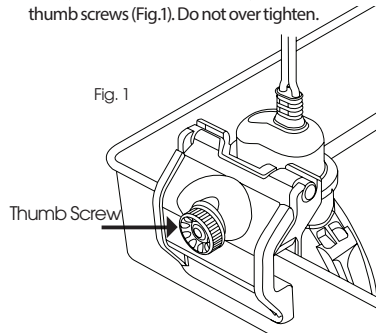

5. Push down on the unit to adjust the depth to the bottom of the pan (Fig.2). Fits pans up to 3" deep.
6. Finish tightening thumb screw.

Fig. 2

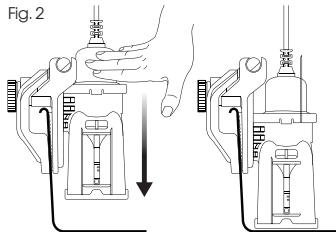

WIRING THE BG-101 IN A CONVENTIONAL HVAC SYSTEM
(To ensure proper performance of product, instructions must be followed.)

1. Ensure the power is disconnected to the unit at the main panel prior to moving to the next step. Refer to the appliance manufacturer's installation and operating instructions and also review wire layout in their instructions.
2. Locate the Red wire coming from the 24 volt thermostat "R" terminal.

NOTE: If not present, it is recommended that an inline fuse to protect 24-volt circuit be installed.

3. Disconnect or cut red wire. Connect one of the long wires of the BG-101, using a wire nut, to the thermostat side of the circuit. Connect the other long wire of the BG-101, using a wire nut, to the air handler side of the circuit or to the terminal in the unit. Incorporating both switch wires in the red circuit will shut the unit off (fig.3)

Fig. 3

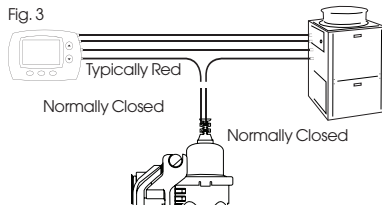

4. TEST THE FLOAT SWITCH

- a. Check that the float is in the lower position. If it is not, lower the float using your finger, as shown on (Fig. 4).
- b. At start up, check initial average load.
- c. With unit on, test switch by raising float as shown. Unit should stop running if switch is correctly wired.
- d. To test switch responsiveness, fill pan with water to ensure that the switch stops the unit before the pan overflows; once confirmed, remove the water.

Fig. 4

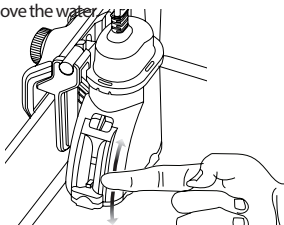

INSTRUCCIONES ESPAÑOL
Visite en línea para obtener instrucciones en español
BigGoose.com/instructions/

For warranty information, please go to
www.biggoose.com



40-001007
REV S

24 volts AC, 4 Amps
US Patents Pending
UL 508 APPROVED