

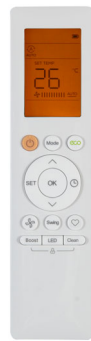

# Product Data



**Fig. 1 — Sizes 09 to 24**



**Fig. 2 — Remote Controller**

**NOTE:** Images are for illustration purposes **only**. Actual models may differ slightly.

## INDUSTRY LEADING FEATURES / BENEFITS

### A PERFECT BALANCE BETWEEN BUDGET LIMITS, ENERGY SAVINGS AND COMFORT

The DHMOVHA series ductless systems are a matched combination of an outdoor condensing unit and an indoor fan coil unit connected only by refrigerant tubing and wires.

The fan coil is mounted on the wall, near the ceiling. This selection of fan coils permits creative solutions to design problems such as:

- Add-ons to current space (an office or family room addition)
- Special space requirements
- When changes in the load cannot be handled by the existing system
- When adding air conditioning to spaces that are heated by hydronic or electric heat and have no ductwork
- Historical renovations or any application where preserving the look of the original structure is essential.

The ideal compliment to your ducted system when it is impractical or prohibitively expensive to use ductwork. These compact indoor fan coil units take up very little space in the room and do not obstruct windows. The fan coils are attractively styled to blend with most room decors. Advanced system components incorporate innovative technology to provide reliable cooling performance at low sound levels.

## TABLE OF CONTENTS

INDUSTRY LEADING FEATURES / BENEFITS.....	1
MODEL NUMBER NOMENCLATURE .....	3
STANDARD FEATURES AND ACCESSORIES .....	4
DIMENSIONS .....	5
CLEARANCES.....	5
COIL SPECIFICATIONS - HEAT PUMP.....	6
FAN AND MOTOR SPECIFICATIONS.....	7
AIR FLOW DATA .....	8
AIR THROW DATA .....	8
MOISTURE REMOVAL.....	8
SOUND PRESSURE .....	8
APPLICATION DATA .....	9
WIRING.....	10
WIRING DIAGRAMS.....	11
GUIDE SPECIFICATIONS.....	12

## **LOW SOUND LEVELS**

When noise is a concern, the ductless systems are the answer. The indoor units are whisper quiet. There are no compressors indoors, either in the conditioned space or directly over it, and there is none of the noise usually generated by air being forced through ductwork.

## **SECURE OPERATION**

If security is an issue, outdoor and indoor units are connected only by refrigerant piping and wiring to prevent intruders from crawling through the ductwork. In addition, since outdoor units can be installed close to an outside wall, coils are protected from vandals and severe weather.

## **FAST INSTALLATION**

This compact ductless system is simple to install. A mounting bracket and duct work is needed for the indoor units, and only wire and piping need run between the indoor and outdoor units. These units are fast and easy to install ensuring minimal disruption to customers in the home or workplace. This makes the air handler systems the equipment of choice, especially in retrofit situations.

## **SIMPLE SERVICING AND MAINTENANCE**

Removing the top panel on outdoor units provides immediate access to the control compartment, providing a service technician access to check unit operation. In addition, the draw-thru design of the outdoor section means that dirt accumulates on the outside surface of the coil. Coils can be cleaned quickly from the inside using a pressure hose and detergent.

On all indoor units, service and maintenance expense is reduced due to easy-to-use cleanable filters. In addition, these high wall systems have extensive self-diagnostics to assist in troubleshooting.

## **BUILT-IN RELIABILITY**

Ductless system indoor and outdoor units are designed to provide years of trouble-free operation.

The high wall indoor units include protection against freeze-up and high evaporator temperatures on heat pumps.

The condensing units on heat pumps are protected by a three minute time delay before the compressor starts the over-current protection and the high temperature protection.

## **INDIVIDUAL ROOM COMFORT**

Maximum comfort is provided because each space can be controlled individually based on usage pattern. The air sweep feature provided permits optimal room air mixing to eliminate hot and cold spots for occupant comfort. In addition, year-round comfort can be provided with heat pumps.

## **ECONOMICAL OPERATION**

The ductless system design allows individual room heating or cooling when required. There is no need to run large supply-air fans or chilled water pumps to handle a few spaces with unique load patterns. In addition, because air is moved only in the space required, no energy is wasted while air moves through the ducts.

## **EASY-TO-USE CONTROLS**

The high wall units have microprocessor-based controls to provide the ultimate in comfort and efficiency. The user friendly wireless remote control provides the interface between the user and the unit.

## **ACCESSORIES**

Customizing these ductless systems to your application is easily accomplished. Adding a condensate pump accessory to the high wall fan coil provides installation flexibility.

## **OPTIONAL WIRED CONTROLLER**

## **AGENCY LISTINGS**

All systems are listed with AHRI (Air Conditioning, Heating & Refrigeration Institute), and UL.

# MODEL NUMBER NOMENCLATURE

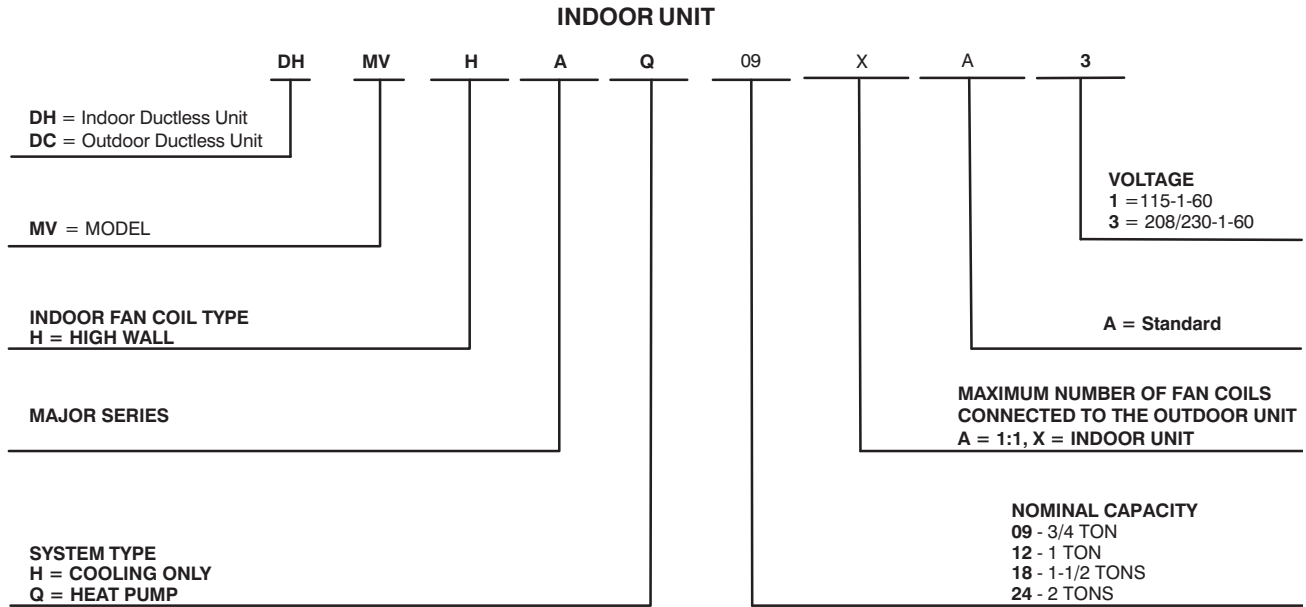

Use of the AHRI Certified TM Mark indicates a manufacturer's participation in the program. For verification of certification for individual products, go to [www.ahridirectory.org](http://www.ahridirectory.org).



# STANDARD FEATURES AND ACCESSORIES

## INDOOR UNITS

Ease Of Installation	
Mounting Brackets	S
Low Voltage Controls	S
Comfort Features	
Microprocessor Controls	S
Wired Remote Controller	A
Wireless Remote Controller	S
Automatic Up-Down Airflow Louver Swing	S
Air Direction Control	S
Auto Restart Function	S
Cold Blow Protection on Heat Pumps	S
Freeze Protection Mode on Heat Pumps	S
Boost Mode	S
Auto Changeover on Heat Pumps	S
Follow Me	S
Energy Saving Features	
Sleep Mode	S
Stop/Start Timer	S
46°F Heating Mode (Heating Setback)	S
Safety And Reliability	
Indoor Coil Freeze Protection	S
Indoor Coil High Temp Protection in Heating Mode	S
Ease Of Service And Maintenance	
Cleanable Filters	S
Diagnostics	S
Application Flexibility	
Condensate Pumps	A

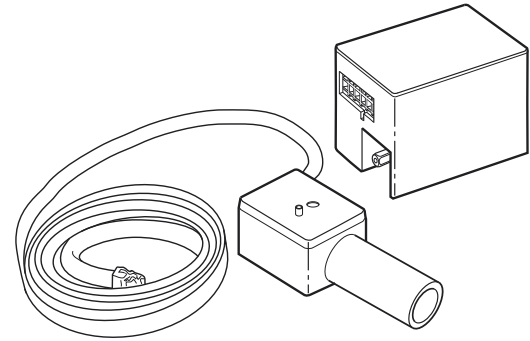

**Fig. 3 — Condensate Pump Accessory**

On high wall fan coils, the condensate pump has a lift capability of 12 ft. (3.6 m) on the discharge side with the pump mounted in the fan coil or 6 ft. (1.8 m) on the suction side if the pump is remote mounted. The pump is recommended when an adequate drain line pitch cannot be provided, or when the condensate must move up to exit.

**NOTE: An external 115v power source is required to run the pump on unit size 12k.**

### Legend

S - Standard  
A - Accessory

## ACCESSORIES

ACCESSORY NO.	DESCRIPTION	FOR MODELS
53DS-900---117	CONDENSATE PUMP (115V)	SIZE 12 (115V)
53DS-900---118	CONDENSATE PUMP (208-230V)	SIZES 09, 12, 18, 24, (208-230V)
KSACN0101AAA	WIRED REMOTE CONTROL	All Sizes

# DIMENSIONS

HIGH WALL UNIT SIZE		9K	12K	9K	12K	18K	24K
Voltage		(115V)	(115V)	(208/230V)	(208/230V)	(208/230V)	(208/230V)
Height	In. (mm)	11.22(285)	11.22(285)	11.22(285)	11.22(285)	11.89(302)	12.80(325)
Width	In. (mm)	28.15 (715)	31.69(805)	31.69(805)	31.69(805)	37.68(957)	40.87(1038)
Depth	In. (mm)	7.68(195)	7.68(195)	7.68(195)	7.68(195)	8.39(213)	8.66(220)
Weight-Net (Heat Pump)	Lbs (kg)	15.9 (7.2)	17.2(7.8)	17.2(7.8)	17.2(7.8)	22.9(10.4)	28.88(13.1)

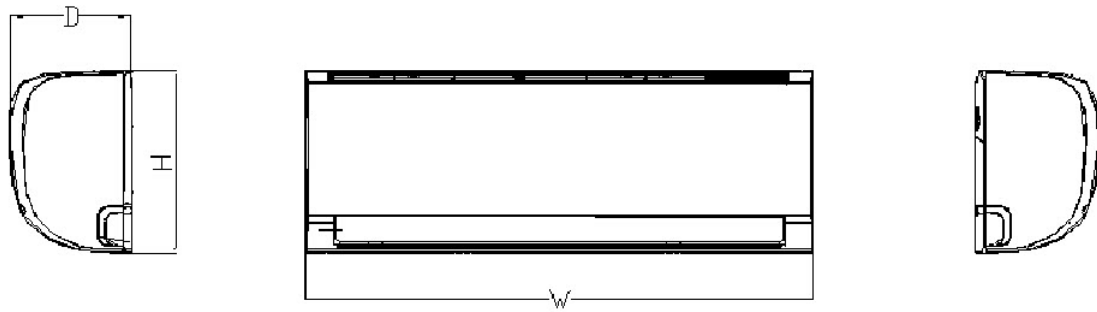

Fig. 4 — Dimensions

# CLEARANCES

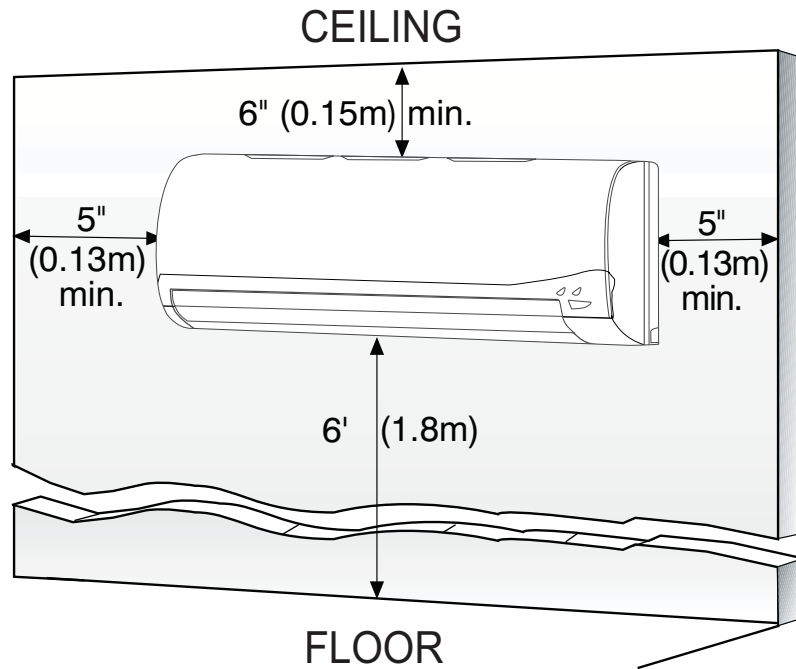

Fig. 5 — Indoor Unit Clearances

# COIL SPECIFICATIONS - HEAT PUMP

SYSTEM SIZE			9K	12K	9K	12K	18K	24K	
			115 V	115V	(208/230 V)	(208/230 V)	(208/230 V)	(208/230 V)	
HIGH WALL INDOOR COIL	Number of rows		2	2	2	2	2	2	
	Tube pitch (a)x row pitch (b)	inch	0.77x0.46	0.77x0.46	0.77x0.46	0.77x0.46	0.83x0.53	0.83x0.53	
		mm	19.5x11.6	19.5x11.6	19.5x11.6	19.5x11.6	21x13.37	21x13.37	
	Fin Spacing	FPI	21	21	21	21	21	20	
		mm	1.2	1.2	1.2	1.2	1.2	1.3	
	Fin type		Louvered	Louvered	Louvered	Louvered	Louvered	Louvered	
	Fin Material		Gold hydrophilic aluminum	Gold hydrophilic aluminum	Gold hydrophilic aluminum	Gold hydrophilic aluminum	Gold hydrophilic aluminum	Gold hydrophilic aluminum	
	Tube outside diameter	inch	0.197	0.197	0.197	0.197	0.276	0.276	
		mm	5	5	5	5	7	7	
	Nominal Tube Wall	Inch (mm)	(0.00787) 0.2				0.00945 (0.24)		
	Tube Enhancement	(Yes/No)	Yes	Yes	Yes	Yes	Yes	Yes	
	Tube Material		Copper	Copper	Copper	Copper	Copper	Copper	
	Coil Length x Height x Width	inch	20.1*3.07*0.91+ 20.1*3.84*0.91+ 0.1*3.07*0.91	23.43*3.07*0.91+ 23.43*4.61*0.91+ 23.43*3.07*0.91	23.43*3.07*0.91+ 23.43*4.61*0.91+ 23.43*3.07*0.91	23.43*3.07*0.91+ 23.43*4.61*0.91+ 23.43*3.07*0.91	29.53*7.44*1.05 +29.53*4.13*1.05	30.71*8.27*1.05 +30.71*4.13*1.05	
		mm	510x78x23.2+ 510x97.5x23.2+ 510x78x23.2	595x78x23.2+ 595x117x23.2+ 595x78x23.2	595x78x23.2+ 595x117x23.2+ 595x78x23.2	595x78x23.2+ 595x117x23.2+ 595x78x23.2	750x189x26.74 + 750x105x26.74	780x210x26.74 + 780x105x26.74	
	Face area	ft <sup>2</sup>	1.39	1.75	1.75	1.75	2.37	2.64	
	Number of Circuits		3	4	4	4	3	4	
	High Burst Pressure	Psi (MPa)	550(3.79)	550(3.79)	550(3.79)	550(3.79)	550(3.79)	550(3.79)	
	Low Burst Pressure	Psi (MPa)	340(2.34)	340(2.34)	340(2.34)	340(2.34)	340(2.34)	340(2.34)	
Gas Pipe (size – connection type)	In (mm)	0.375 (9.52)	0.375 (9.52)	0.375 (9.52)	0.375 (9.52)	0.5 (12.7)	0.626 (15.9)		
Liquid Pipe (size – connection type)	In (mm)	0.25 (6.35)					0.375 (9.52)		
Connecting Liquid Line Length	ft (m)	82(25)	82(25)	82(25)	82(25)	98.4(30)	164(50)		
Connecting Gas Line Length	ft (m)	82(25)	82(25)	82(25)	82(25)	98.4(30)	164(50)		

# FAN AND MOTOR SPECIFICATIONS

HIGH WALL UNIT SIZE			9K	12K	9K	12K	18K	24K
			(115V)	(115V)	(208/230V)	(208/230V)	(208/230V)	(208/230V)
HIGH WALL FAN	Material		Acrylonitrile Styrene +30%GF	Acrylonitrile Styrene +30%GF	Acrylonitrile Styrene +30%GF	Acrylonitrile Styrene +30%GF	Acrylonitrile Styrene +30%GF	Acrylonitrile Styrene +30%GF
	Type		GL-94*516-I	GL-94*605-N	GL-94*605-N	GL-94*605-N	GL-98*758-I	GL-107.5*780-IN
	Diameter	In (mm)	3.7(94)	3.7(94)	3.7(94)	3.7(94)	3.86(98)	4.23(107.5)
	Height	In (mm)	20.3(516)	23.8(605)	23.8(605)	23.8(605)	29.8(758)	30.7(780)
HIGH WALL FAN MOTOR	Model		YKFG-15-4-28-1	YKFG-15-4-28-1	YKFG-20-4-10L	YKFG-20-4-10L	YKFG-28-4-6-5	YKFG-45-4-13
	Volts	V	115	115	220	220	220	220
	Phase		1	1	1	1	1	1
	FLA		0.40	0.40	0.40	0.40	0.40	0.45
	Type		AC					
	Insulation class		B (board ocean), / A(Welling)/E (Green-Intelligence)	B (board ocean), / A(Welling)/E (Green-Intelligence)	E	E	E	B
	Safe class		IPX0	IPX0	IPX0	IPX0	IPX0	IPX0
	Input	W	46(board ocean, Welling)/39 (Green-Intelligence)	46(board ocean, Welling)/ 39(Green-Intelligence)	49.5(board ocean),/ 47.5(Welling)/ 46(Green-Intelligence)	49.5(board ocean),/ 47.5(Welling)/ 46(Green-Intelligence)	56.6(board ocean),/ 58.5(Welling)	89(Welling)/ 90(Dongfang)
	Output	W	15	15	20	20	28	45
	Range of current	Amps	0.45±10% (board ocean)/ 0.425±10% (welling)/ 0.48±10% (Green-Intelligence)	0.35±10% (board ocean)/ 0.425±10% (welling)/ 0.48±10% (Green-Intelligence)	0.23±10% (board ocean)/ 0.22±10% (welling)/ 0.21±10% (Green-Intelligence)	0.23±10% (board ocean)/ 0.22±10% (welling)/ 0.21±10% (Green-Intelligence)	0.26±10% (board ocean)/ 0.27±10% (welling)	0.4±10% (welling)/ 0.39±10% (Dongfang)
	Rated current	Amps	0.35 (board ocean)/0.43 (welling)/0.37 (Green-Intelligence)	0.35 (board ocean)/0.43 (welling)/0.37 (Green-Intelligence)	0.23 (board ocean)/0.22 (welling)/0.2 (Green-Intelligence)	0.23 (board ocean)/0.22 (welling)/0.2 (Green-Intelligence)	0.26 (board ocean)/0.27 (welling)	0.4 (welling)/ 0.39 (Dongfang)
	Capacitor	μF	3	3	1.5	1.5	1.5	3
	Rated HP	HP	0.02	0.02	0.027	0.027	0.037	0.06
	Speed	rev/min	1180/950/750	1180/950/750	1180/950/750	1180/950/750	1200/1000/800	1200/1000/800
Rated RPM	rev/min	1180	1180	1180	1180	1200	1200	
Max. input	W	66(board ocean)/ 56 (welling)/48 (Green-Intelligence)	66(board ocean)/ 56 (welling)/48 (Green-Intelligence)	60(board ocean)/ 50 (welling)/51.6 (Green-Intelligence)	60(board ocean)/ 50 (welling)/51.6 (Green-Intelligence)	76(board ocean)/ 74.4 (welling)	134(welling)/ 120(Dongfang)	

## COMPATIBILITY

Indoor Units	DHMVHAQ09XA1	DHMVHAQ12XA1	DHMVHAQ09XA3	DHMVHAQ12XA3	DHMVHAQ18XA3	DHMVHAQ24XA3
Outdoor Units Single Zone	38MVRAQ09AA1	38MVRAQ12AA1	38MVRAQ09AA3	38MVRAQ12AA3	38MVRAQ18AA3	38MVRAQ24AA3

## AIR FLOW DATA

SYSTEM SIZE		9K (115V)	12K (115V)	9K (208/230V)	12K (208/230V)	18K (208/230V)	24K (208/230V)
Indoor (CFM)	Turbo	294	353	353	353	510	588
	High	265	318	318	318	424	565
	Medium	212	241	241	241	341	447
	Low	159	176	176	176	200	341

## AIR THROW DATA

HIGH WALL UNIT CAPACITY	MAX. APPROXIMATE AIR THROW FT. (M)
9K (115)	24.6 (7.5)
12K (115)	26.5 (8.1)
9K (208)	25.9 (7.9)
12K (208)	25.9 (7.9)
18K (208)	28.5 (8.7)
24K (208)	31.1 (9.5)

## MOISTURE REMOVAL

SIZE		9	12	9	12	18	24
Voltage, Phase, Cycle	V/Ph/Hz	115-1-60	115-1-60	208/230-1-60	208/230-1-60	208/230-1-60	208/230-1-60
Dehumidifying Volume	L/h	1.16	1.58	1.59	1.59	2.2	3.18
Dehumidifying Volume	PINT/h	2.45	3.34	3.36	3.36	4.65	6.72

## SOUND PRESSURE

HIGH WALLS INDOOR		9K (115V)	12K (115V)	9K (208/230V)	12K (208/230V)	18K (208/230V)	24K (208/230V)
Cooling Operation Indoor	dB(A) at (High / Med /Low CFM)	39.5/33.5/26	41/34.5/27.5	41/34.5/27.5	41/34.5/27.5	43.5/38/30	46/40/33.5
Heating Operation Indoor Sound Pressure	dB(A) at (High / Med /Low CFM)	39.5/33.5/26	41/34.5/27.5	41/34.5/27.5	41/34.5/27.5	43.5/38/30	46/40/33.5



## APPLICATION DATA

### UNIT SELECTION

Select equipment that either matches or is supports slightly more than the anticipated peak load. This provides better humidity control, fewer unit cycles, and less part-load operation.

For units used in spaces with high sensible loads, base equipment selection on unit sensible load, not on total anticipated load. Adjust for anticipated room wet bulb temperature to avoid undersizing the equipment.

### UNIT MOUNTING (INDOOR)

Refer to the unit's installation instructions for further details.

**Unit leveling** - For reliable operation, units should be level in all planes.

**Clearance** - Provide adequate clearance for airflow (see Fig. 5).

**Unit location** - Select a location which provides the best air circulation for the room. These units should be positioned as high as possible on the wall for the best air circulation. The unit return and discharge should not be obstructed by furniture, curtains, or anything which may cause unit short cycling or air recirculation.

Place the unit in the middle of the selected wall (if possible). Use an outside wall, if available, to make piping easier, and place the unit so it faces the normal location of room occupants.

### UNIT MOUNTING (OUTDOOR)

Refer to the unit's installation instructions for further details.

Do not install the indoor or outdoor units in a location with special environmental conditions. For those applications, contact your Ductless representative.

### MOUNTING TEMPLATE

Refer to the unit's installation instructions for further details.

The fan coil units are furnished with mounting to mark the location of the wiring, and the refrigeration line hole locations.

### CONTROL SYSTEM

The indoor unit is equipped with a microprocessor control to perform two functions:

1. Provide safety for the system
2. Control the system and provide optimum levels of comfort and efficiency.

The main microprocessor is located on the control board of the fan coil unit (outdoor units also have a microprocessor) with thermistors located in the fan coil air inlet and on the indoor coil.

The heat pump units have a thermistor on the outdoor coil. These thermistors monitor the system operation to maintain the unit within acceptable parameters and controls the operating mode.

## Wireless Remote Control



**Fig. 6 — Wireless Remote Control**

1. A wireless remote control is supplied for system operation for system operation of all high wall units.
2. Each battery operated wireless (infrared) remote control may be used to control more than one unit.

## WIRED REMOTE CONTROL (OPTIONAL)

### P/N KSACN0101AAA

1. Optional wired remote controller used for system operation of all high wall units.
2. Kit includes a wired remote controller and a connecting cable.
3. Connect with wire terminal between remote controller and indoor unit.

Display in °F or °C and temperature increments every 1°F or every 1°C.

## SUPPORT

Adequate support must be provided to support the weight of all the fan coils. Refer to the Physical Data section for fan coil weights, and the base unit dimensional drawings for the mounting bracket locations.

## SYSTEM OPERATING CONDITIONS

OPERATING RANGE MIN/MAX °F/°C		
	COOLING	HEATING
Indoor DB	63 / 90 (17 / 32)	32 / 86 (0 / 30)

**NOTE: Reference the product installation instructions for more information.**

## DRAIN CONNECTIONS

Install drains to meet the local sanitation codes. If adequate gravity drainage cannot be provided, the unit should be equipped with an accessory condensate pump. The high wall fan coil unit condensate pumps have a maximum lift of 10' (3.05 m) for 9k and 12k units and 25' (7.62 m) for 18k and 24k units.

**Field drain pipe O.D. is 0.625 in (16 mm) for all sizes.**

**NOTE: High wall fan coil units have internal condensate traps. A trap is not required.**

Drain connections may be routed through alternate locations on most fan coils (see Fig. 7).

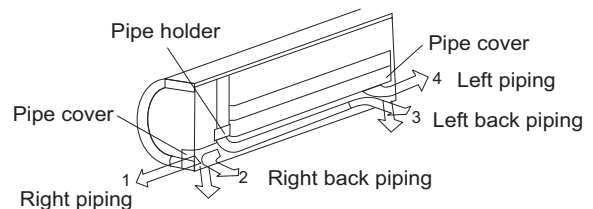

**Fig. 7 — Piping Connections**

## WIRING

All wires must be sized per NEC (National Electrical Code) or CEC (Canadian Electrical Code) and local codes. Use Electrical Data table MCA (minimum circuit amps) and MOCP (maximum over current protection) to correctly size the wires and the disconnect fuse or breakers respectively. Per the caution note, only stranded copper conductors with a 600 volt rating and double insulated copper wire must be used.

The use of BX cable is not recommended.

### **Recommended Connection Method for Power and Communication Wiring - Power and Communication Wiring:**

The main power is supplied to the outdoor unit. The field supplied 14/3 power/communication wiring from the outdoor unit to indoor unit consists of four (4) wires and provides the power for the indoor unit. Two wires are high voltage AC power, one is communication wiring and the other is a ground wire.

### **Recommended Connection Method for Power and Communication Wiring (To minimize communication wiring interference)**

#### **Power Wiring:**

The main power is supplied to the outdoor unit. The field supplied power wiring from the outdoor unit to indoor unit consists of three (3) wires and provides the power for the indoor unit. Two wires are high voltage AC power and one is a ground wire.

To minimize voltage drop, the factory recommended wire size is 14/2 stranded with a ground.

#### **Communication Wiring:**

A separate shielded Stranded copper conductor only, with a 600 volt rating and double insulated copper wire, must be used as the communication wire from the outdoor unit to the indoor unit. Please use a separate shielded 16GA stranded control wire.



## CAUTION

### **EQUIPMENT DAMAGE HAZARD**

Failure to follow this caution may result in equipment damage or improper operation.

Wires should be sized based on NEC and local codes.

Use copper conductors only with a 600 volt rating and double insulated copper wire.



## CAUTION

### **EQUIPMENT DAMAGE HAZARD**

Failure to follow this caution may result in equipment damage or improper operation.

Be sure to comply with local codes while running wire from the indoor unit to the outdoor unit.

Every wire must be connected firmly. Loose wiring may cause the terminal to overheat or result in unit malfunction. A fire hazard may also exist. Ensure all wiring is tightly connected. No wire should touch the refrigerant tubing, compressor or any moving parts.

Disconnecting means must be provided and shall be located within sight and readily accessible from the air conditioner.

Connecting cable with conduit shall be routed through the hole in the conduit panel.

# WIRING DIAGRAMS

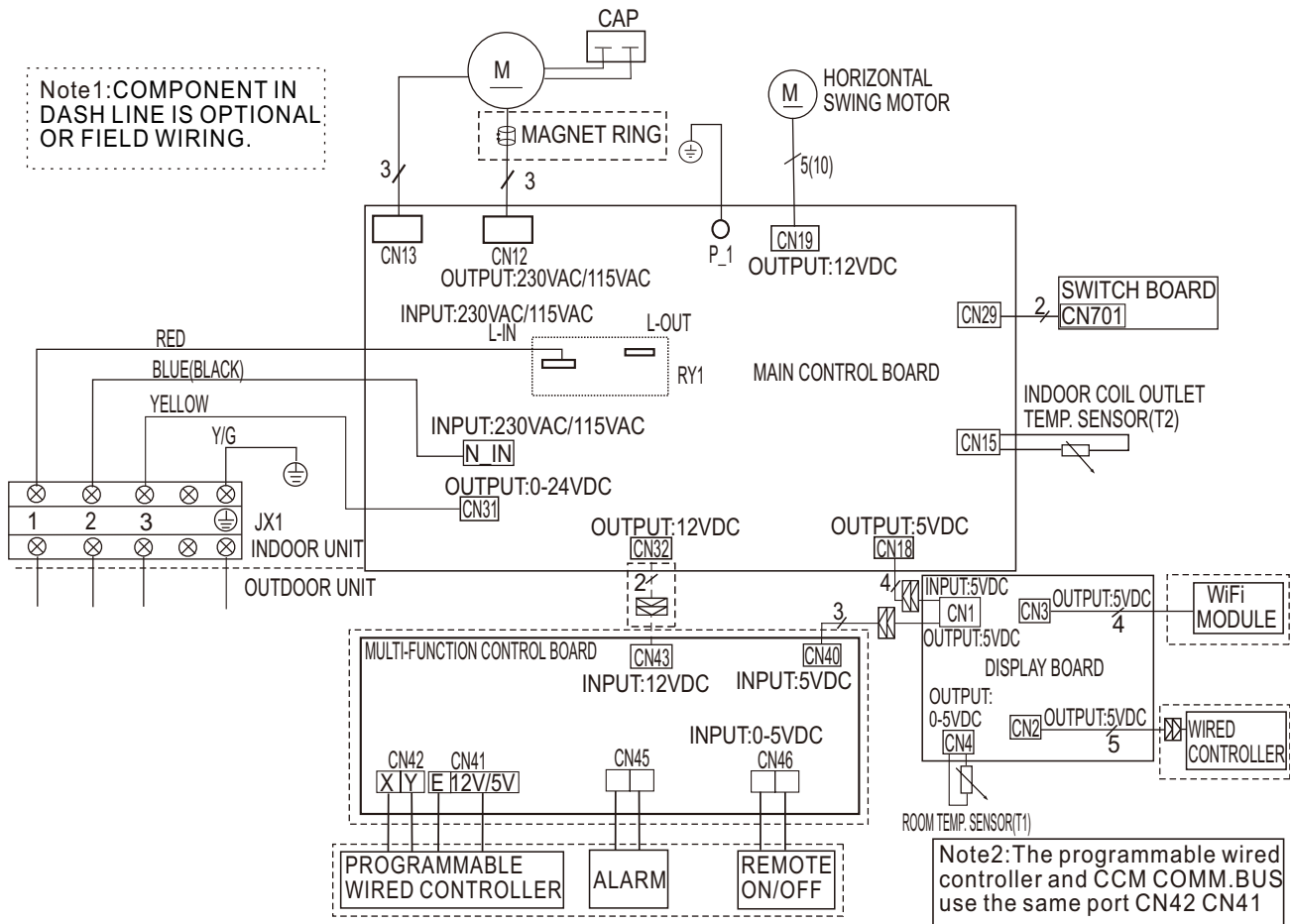

Fig. 8 — Wiring Diagram Sizes 9K (115V) - 24K (208/230V)

## Part 1 - GENERAL

### 1.01 System Description

Indoor, wall-mounted, direct-expansion fan coils are matched with the heat pump outdoor unit.

### 1.02 Agency Listings

Unit is rated per AHRI Standards 210/240 and listed in the AHRI directory as a matched system.

### 1.03 Delivery, Storage, And Handling

Units are stored and handled per the unit manufacturer's recommendations.

### 1.04 Warranty (For Inclusion By Specifying Engineer)

## Part 2 - PRODUCTS

### 2.01 Equipment

#### **A. General:**

Indoor, direct-expansion, ceiling-mounted fan coil. The unit is complete with a cooling/heating coil, fan, fan motor, piping connectors, electrical controls, microprocessor control system, and integral temperature sensing. The unit is furnished with an integral wall mounting bracket and mounting hardware.

#### **B. Unit Cabinet:**

The cabinet discharge and inlet grilles are attractively styled, high-impact polystyrene. The cabinet is fully insulated for improved thermal and acoustic performance.

#### **C. Fans:**

1. Fan is the tangential direct-drive blower type with air intake at the top of the unit and discharge at the bottom front. An automatic, motor-driven vertical air sweep is provided as standard equipment.
2. The air sweep operation is user selectable. The vertical sweep may be adjusted (using the remote control). The horizontal air direction may be set manually.

#### **D. Coil:**

The coil is a copper tube with aluminum fins and galvanized steel tube sheets. The fins are bonded to the tubes by mechanical expansion and blue hydrophilic pre-coated. A drip pan, under the coil, has a drain connection for the hose attachment to remove condensate. The condensate pan has an internal trap.

#### **E. Motors:**

The motors are open drip-proof, with a permanently lubricated ball bearing. The fan motors are 3-speed.

#### **F. Controls:**

The controls consist of a microprocessor-based control system which controls the space temperature, determines the optimum fan speed, and runs self diagnostics. The temperature control range is from 62°F to 86°F (17°C to 30°C) in increments of 1°F or 1°C, and have 46°F Heating Mode (Heating Setback). The wireless remote controller has the ability to act as the temperature sensing location for room comfort.

## GUIDE SPECIFICATIONS INDOOR AIR HANDLER DUCTLESS SYSTEMS

Size Range: 3/4 to 2 Ton Nominal Cooling and Heating Capacity Model Number: **DHMVHA**

### **The unit has the following functions (at a minimum):**

1. An automatic restart after a power failure at the same operating conditions as at the failure.
2. A timer function to provide a minimum 24-hour timer cycle for system Auto Start/Stop.
3. Temperature-sensing controls have sense return air temperature.
4. Indoor coil freeze protection.
5. Wireless infrared remote control to enter set points and operating conditions.
6. Automatic air sweep control to provide on or off activation of air sweep louvers.
7. Dehumidification mode provides increased latent removal capability by modulating the system operation and the set point temperature.
8. Fan-only operation to provide room air circulation when no cooling is required.
9. Diagnostics provide continuous checks of unit operation and warn of possible malfunctions. Error messages appear on the unit.
10. Fan speed control is user-selectable: turbo, high, medium, low, or microprocessor controlled automatic operation during all operating modes.
11. Automatic heating-to-cooling changeover in the heat pump mode. The control includes a deadband to prevent rapid mode cycling between heating and cooling.
12. Indoor coil high temperature protection are provided to detect excessive indoor discharge temperature when the unit is in the heat pump mode.

#### **G. Filters:**

Unit has a filter track with factory-supplied cleanable filters.

#### **H. Electrical Requirements:**

Indoor fan motor to operate on 115V on model sizes 09-12 and on 208-230V on model sizes 09-24, as specified. Power is supplied by the outdoor unit.

#### **I. Operating Characteristics:**

The system has a minimum SEER (Seasonal Energy Efficiency Ratio) and HSPF at AHRI conditions, as listed on the specifications table.

#### **J. Refrigerant Lines:**

All units should have refrigerant lines that can be oriented to connect from the left, right or back of unit. Both refrigerant lines need to be insulated.

#### **K. Special Features (Field Installed):**

The condensate pump removes condensate from the drain pan when gravity drainage cannot be used. The pump is designed for quiet operation. The pump consists of two parts: an internal reservoir/sensor assembly, and a remote sound-shielded pump assembly. A liquid level sensor in the reservoir stops the cooling operation if the liquid level in the reservoir is unacceptable.