

45MBDA

Slim Ductless System
Sizes 6 to 58



Product Data



Fig. 1 – Sizes 06K-18K (Low Static)

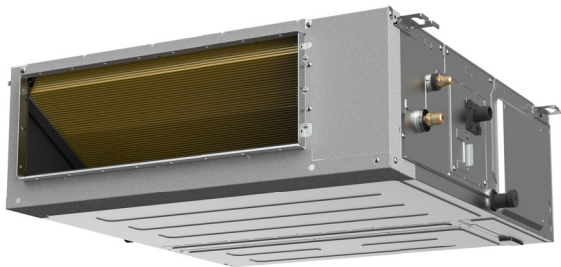

Fig. 2 – Sizes 9K-58K (High Static)

NOTE: Images are for illustration purposes only. Actual models may differ slightly.

TABLE OF CONTENTS

	<u>Page</u>
SAFETY CONSIDERATIONS	1
INDUSTRY LEADING FEATURES / BENEFITS	3
MODEL NUMBER NOMENCLATURE	5
STANDARD FEATURES AND ACCESSORIES	6
DIMENSIONS	7
MAINTENANCE CLEARANCES	11
SPECIFICATIONS (HIGH STATIC)	12
SPECIFICATIONS (low Static).....	14
APPLICATION DATA	15
WIRING	15
WIRING CONNECTIONS	17
ELECTRICAL DATA	17
CONTROL SYSTEM.....	17
WIRELESS REMOTE CONTROLLER	17
WIRED REMOTE CONTROLLER	17
AIR FLOW DATA	17
SOUND PRESSURE	18
FAN AND MOTOR SPECIFICATIONS.....	18
SOUND PRESSURE TESTING METHOD	18
FAN PERFORMANCES AT VARYING STATIC PRESSURES .	18

FAN PERFORMANCES AT VARYING STATIC PRESSURES —	
LOW STATIC	27
.....	31
FAN PERFORMANCES AT VARYING STATIC PRESSURES —	
HIGH STATIC	32
MOISTURE REMOVAL.....	46
PIPING SPECIFICATIONS.....	46
REFRIGERANT SYSTEM DIAGRAM	47
WIRING DIAGRAMS.....	47
GUIDE SPECIFICATIONS.....	50

SAFETY CONSIDERATIONS

Installing, starting up, and servicing air-conditioning equipment can be hazardous due to system pressures, electrical components, and equipment location (roofs, elevated structures, etc.).

Only trained, qualified installers and service mechanics should install, start-up, and service this equipment.

Untrained personnel can perform basic maintenance functions such as coil cleaning. All other operations should be performed by trained service personnel only.

When working on the equipment, observe the precautions in the literature and on tags, stickers, and labels attached to the equipment.

Follow all safety codes. Wear safety glasses and work gloves. Keep a quenching cloth and a fire extinguisher nearby when brazing. Use care in handling, rigging, and setting bulky equipment.

Read these instructions thoroughly and follow all warnings or cautions included in the literature and attached to the unit. Consult local building codes and National Electrical Code (NEC) for special requirements. Recognize safety information.

This is the safety - alert symbol .

When you see this symbol on the unit and in instructions or manuals, be alert to the potential for personal injury. Understand these signal words: **DANGER**, **WARNING**, and **CAUTION**. These words are used with the safety- alert symbol.

DANGER identifies the most serious hazards which will result in severe personal injury or death.

WARNING signifies hazards which could result in personal injury or death.

CAUTION is used to identify unsafe practices which may result in minor personal injury or product and property damage.

NOTE is used to highlight suggestions which will result in enhanced installation, reliability, or operation.

! WARNING**ELECTRICAL SHOCK HAZARD**

Failure to follow this warning could result in personal injury or death. Before installing, modifying, or servicing system, the main electrical disconnect switch must be in the OFF position. There may be more than 1 disconnect switch. Lock out and tag switch with a suitable warning label.

! WARNING**EXPLOSION HAZARD**

Failure to follow this warning could result in death, serious personal injury, and/or property damage.

Never use air or gases containing oxygen for leak testing or operating refrigerant compressors. Pressurized mixtures of air or gases containing oxygen can lead to an explosion.

! WARNING

This appliance is not intended for use by persons (including children) with reduced physical, sensory or mental capabilities, or lack of experience and knowledge, unless they have been given supervision or instruction concerning use of the appliance by a person responsible for their safety. Children should be supervised to ensure that they do not play with the appliance.

! WARNING**ELECTRICAL SHOCK HAZARD**

Failure to follow this warning could result in personal injury, death, and/or property damage.

Only use the specified wire. If the wire is damaged, it must be replaced by the manufacturer, its service agent or similarly qualified persons in order to avoid a hazard. The product must be properly grounded at the time of installation, or electric shock may occur.

For all electrical work, follow all local and national wiring standards, regulations, and the Installation Manual. Connect the cables tightly, and clamp them securely to prevent external forces from damaging the terminal. Improper electrical connections can overheat and cause fire, and may also cause shock. All electrical connections must be made according to the Electrical Connection Diagram located on the panels of the indoor and outdoor units.

All wiring must be properly arranged to ensure that the control board cover can close properly. If the control board cover is not closed properly, it can lead to corrosion and cause the connection points on the terminal to heat up, catch fire, or cause electrical shock.

Disconnection must be incorporated in the fixed wiring in accordance with NEC, CSA and Local Codes. Do not share the electrical outlet with other appliances. Improper or insufficient power supply can cause fire or electric shock.

If connecting power to fixed wiring, an all-pole disconnection device which has at least 3mm clearances in all poles, and have a leakage current that may exceed 10mA, the residual current device (RCD) having a rated residual operating current not exceeding 30mA, and disconnection must be incorporated in the fixed wiring in accordance with NEC, CSA and Local Codes.

! WARNING**EQUIPMENT DAMAGE HAZARD**

Failure to follow this caution may result in equipment damage or improper operation.

Do not bury more than 36 in. (914 mm) of refrigerant pipe in the ground. If any section of pipe is buried, there must be a 6 in. (152 mm) vertical rise to the valve connections on the outdoor units. If more than the recommended length is buried, refrigerant may migrate to the cooler buried section during extended periods of system shutdown. This causes refrigerant slugging and could possibly damage the compressor at start-up.

! WARNING**ELECTRICAL SHOCK HAZARD**

Failure to follow this warning could result in personal injury, death, and/or property damage.

Turn off the air conditioner and disconnect the power before performing any installation or repairing. Failure to do so can cause electric shock.

Installation must be performed by an authorized dealer or specialist. Defective installation can cause water leakage, electrical shock, or fire. Installation must be according to the installation instructions.

Improper installation can cause water leakage, electrical shock, or fire. Contact an authorized service technician for repair or maintenance of this unit. This appliance shall be installed in accordance with national wiring regulations.

Only use the included accessories, parts, and specified parts for installation. Using non-standard parts can cause water leakage, electrical shock, fire, and can cause the unit to fail.

Install the unit in a firm location that can support the unit's weight. If the chosen location cannot support the unit's weight, or the installation is not done properly, the unit may drop and cause serious injury and damage. Install drainage piping according to the instructions in this manual. Improper drainage may cause water damage to your home and property. For units that have an auxiliary electric heater, do not install the unit within 3 feet (1 meter) of any combustible materials.

If combustible gas accumulates around the unit, it may cause fire.

Do not turn on the power until all work has been completed.

When moving or relocating the air conditioner, consult experienced service technicians for disconnection and re-installation of the unit.

Read the information for details in "indoor unit installation" and "outdoor unit installation" sections.

NOTE: The air conditioner's circuit board (PCB) is designed with a fuse to provide over-current protection. The specifications of the fuse are printed on the circuit board, for example: T3.15AL/250VAC, T5AL/250VAC, T3.15A/250VAC, T5A/250VAC, T20A/250VAC, T30A/250VAC, etc.

NOTE: Only a blast-proof ceramic fuse can be used.





! WARNING

PERSONAL INJURY AND PROPERTY DAMAGE HAZARD

For continued performance, reliability, and safety, the only approved accessories and replacement parts are those specified by the equipment manufacturer. The use of non-manufacturer approved parts and accessories could invalidate the equipment limited warranty and result in a fire risk, equipment malfunction, and failure.

Please review the manufacturer’s instructions and replacement parts catalogs available from your equipment supplier.

Table 1 – Symbols Displayed on the Indoor or Outdoor Unit

	WARNING	This symbol shows that this appliance used a flammable refrigerant. If the refrigerant is leaked and exposed to an external ignition source, there is a risk of fire.
	CAUTION	This symbol shows that the operation manual should be read carefully.
	CAUTION	This symbol shows that a service personnel should be handling this equipment with reference to the installation manual.
	CAUTION	This symbol shows that information is available such as the operating manual or installation manual.
	CAUTION	This symbol shows that information is available such as the operating manual or installation manual.

! WARNING

FOR FLAMMABLE REFRIGERANTS

Do not use means to accelerate the defrosting process or to clean, other than those recommended by the manufacturer.

The appliance shall be stored in a room without continuously operating ignition sources (for example: open flames, an operating gas appliance or an operating electric heater).

Do not pierce or burn. Be aware that refrigerants may not contain an odor.

R-454B

Refrigerant Safety Group
A2L

R-454B

WARNING – Risk of Fire due to Flammable Refrigerant Used. Follow Handling Instructions Carefully in Compliance with National Regulations

NOTE: Risk of Fire. Flammable refrigerant used. To be repaired only by trained service personnel. Do not puncture refrigerant tubing.

INDUSTRY LEADING FEATURES / BENEFITS

A PERFECT BALANCE BETWEEN BUDGET LIMITS, ENERGY SAVINGS AND COMFORT

The 45MBDA series ductless systems are a matched combination of an outdoor condensing unit and an indoor fan coil unit connected only by refrigerant tubing and wires.

The in-ceiling cassette fan coils are ideal for retrofit or modernization projects where a false ceiling is available. This selection of fan coils permits inexpensive and creative solutions to design problems such as:

- **Add-ons to current space (an office or family room addition)**
- **Special space requirements**
- **When changes in the load cannot be handled by the existing system**
- **Historical renovations or any application where preserving the look of the original structure is essential.**

The ideal complement to your ducted system when it is impractical or prohibitively expensive to use ductwork. These compact indoor fan coil units take up very little space in the room and do not obstruct windows. The fan coils are attractively styled to blend with most room decors. Advanced system components incorporate innovative technology to provide reliable cooling performance at low sound levels.

ECCENTRIC FAN DESIGN

New eccentric fan design improves the airflow at the air outlet, resulting better performance.

SLIM DESIGN

The industry lowest height is designed to be fitted into tight roof spaces.

FLEXIBLE AIR INTAKE

The frame size of air inlet in rear and bottom is the same. It’s very easy to switch to match different applications.

BUILT-IN DRAIN PUMP(OPTIONAL)

The built-in drain pump can lift condensing water up to 29.5" (750mm).

EASY TO CLEAN

You can pull out the filter from left, right, or from the bottom for easy cleaning.

LOW SOUND LEVELS

When noise is a concern, the ductless systems are the answer. The indoor units are whisper quiet. There are no compressors indoors, either in the conditioned space or directly over it, and there is none of the noise usually generated by air being forced through ductwork.

SECURE OPERATION

If security is an issue, outdoor and indoor units are connected only by refrigerant piping and wiring to prevent intruders from crawling through ductwork. In addition, since outdoor units can be installed close to an outside wall, coils are protected from vandals and severe weather.

FAST INSTALLATION

This compact ductless system is simple to install. A mounting bracket is standard with the indoor units and only wire and piping needs to run between indoor and outdoor units. These units are fast and easy to install ensuring minimal disruption to customers in the home or workplace. This makes the ductless systems the equipment of choice, especially in retrofit situations.

BUILT-IN RELIABILITY

Ductless system indoor and outdoor units are designed to provide years of trouble-free operation.

The in-ceiling cassette units include protection against freeze-up and high evaporator temperatures on heat pumps.

The condensing units on heat pumps are protected by a three minute time delay before the compressor starts the over-current protection and the high temperature protection.

ECONOMICAL OPERATION

The ductless system design allows individual room heating or cooling when required. There is no need to run large supply-air fans or chilled water pumps to handle a few spaces with unique load patterns. In addition, because air is moved only in the space required, no energy is wasted moving air through ducts.

EASY-TO-USE CONTROLS

The in-ceiling cassette has microprocessor-based controls to provide the ultimate in comfort and efficiency. The user friendly wireless remote control provides the interface between user and the unit.

SIMPLE SERVICING AND MAINTENANCE

Removing the top panel on outdoor units provides immediate access to the control compartment, providing a service technician access to check unit operation. In addition, the draw-thru design of the outdoor section means that dirt accumulates on the outside surface of the coil. Coils can be cleaned quickly from inside using a pressure hose and detergent.

On all indoor units, service and maintenance expense is reduced due to easy-to-use cleanable filters. In addition, these cassette systems have extensive self-diagnostics to assist in troubleshooting.

INDIVIDUAL ROOM COMFORT

Maximum comfort is provided because each space can be controlled individually based on usage pattern. The air sweep feature provided permits optimal room air mixing to eliminate hot and cold spots for occupant comfort. In addition, year-round comfort can be provided with heat pumps.

FACTORY INSTALLED CONDENSATE LIFT PUMP

Customizing these ductless systems to your application is easily accomplished. The factory installed condensate lift pump on the cassette fan coil unit provides installation flexibility.

OPTIONAL WIRED CONTROLLER

AGENCY LISTINGS

All systems are listed with AHRI (Air Conditioning, Heating & Refrigeration Institute), and ETL.

FCC

This device complies with part 15 of the FCC Rules. Operation is subject to the following two conditions: (1) This device may not cause harmful interference, and (2) this device must accept any interference received, including interference that may cause undesired operation.

FOR CLASS B DIGITAL DEVICE

NOTE: This equipment has been tested and found to comply with the limits for a Class B digital device, pursuant to part 15 of the FCC Rules. These limits are designed to provide reasonable protection against harmful interference in a residential installation. This equipment generates, uses and can radiate radio frequency energy and, if not installed and used in accordance with the instructions may cause harmful interference to radio communications. However, there is no guarantee that interference will not occur in a particular installation. If this equipment does cause harmful interference to radio or television reception, which can be determined by turning the equipment off and on, the user is encouraged to try to correct the interference by one or more of the following measures:

- Reorient or relocate the receiving antenna
- Increase the distance between the equipment and the receiver
- Connect the equipment into an outlet on a circuit different from that to which the receiver is connected.
- Consult the dealer or an experienced radio/TV technician for assistance.

MODIFICATION

Any changes or modifications not expressly approved by the grantee of this device could void the user's authority to operate this device.

MODEL NUMBER NOMENCLATURE

INDOOR UNIT

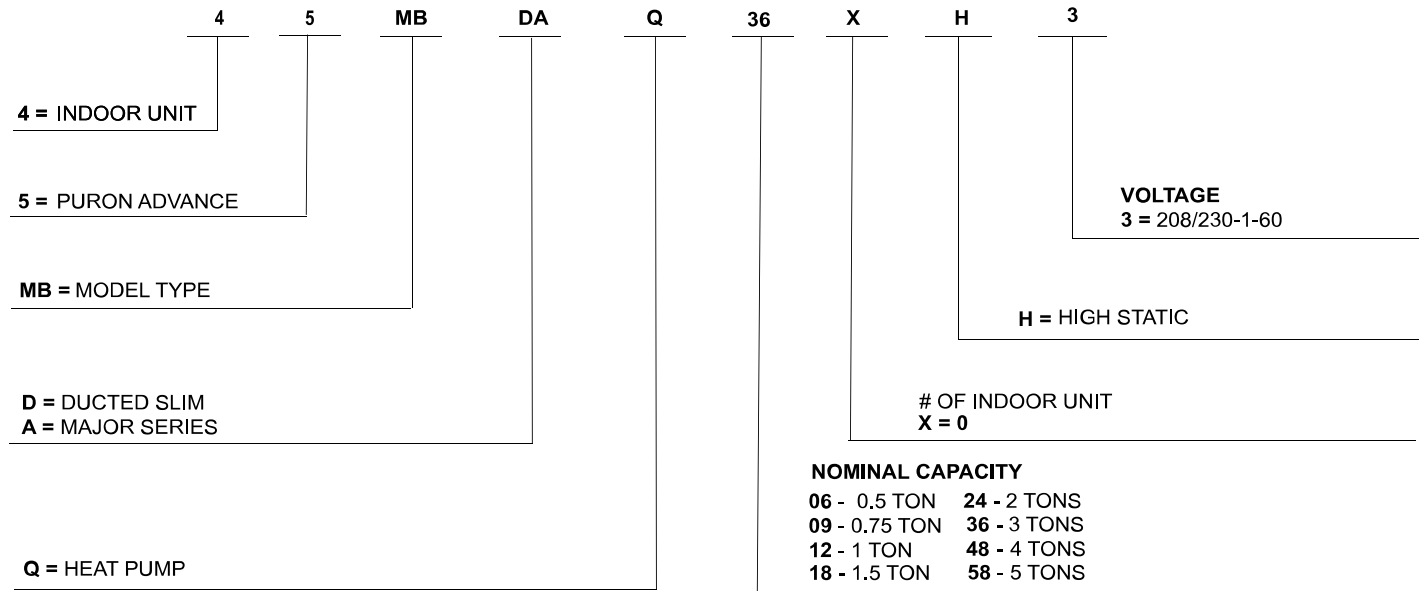

Use of the AHRI Certified TM Mark indicates a manufacturer's participation in the program. For verification of certification for individual products, go to www.ahridirectory.org.



STANDARD FEATURES AND ACCESSORIES

FEATURES

Ease Of Installation		
	Mounting Brackets	
	Low Voltage Controls	
Comfort Features		
	Rear or Bottom Return (Bottom Return only sizes 06K-48K)	
	Vertical (Up flow) or horizontal installation (Vertical only sizes 06K-48K)	
	Microprocessor Controls	
	Wired Remote Control (7 Day Programmable KSCAN1401AAA)	
	Wireless Remote Control	
	Air Direction Control	
	Auto Restart Function	
	Cold Blow Protection On Heat Pumps	
	Freeze Protection Mode On Heat Pumps	
	Turbo Mode	
	Auto Changeover On Heat Pumps	
	Follow Me (Sense Temperature at remote)	
Energy Saving Features		
	Outside Air Intake	
	Sleep Mode	
	Stop/Start Timer	
	46°F Heating Mode (Heating Setback)	
Safety And Reliability		
	Indoor Coil Freeze Protection	
	Indoor Coil High Temp Protection in Heating Mode	
	Aluminum Golden Hydrophilic pre-coated fins	
	The unit is equipped with a refrigerant leak detection sensor	
Ease Of Service And Maintenance		
	Cleanable Filters	
	Diagnostics	
	Liquid Line Pressure Taps	
Application Flexibility		
	External Condensate Lift Pump shipped with the unit (sizes 06K-18K)	
	Built-in Condensate Lift Pump (High Static, sizes 09K-58K)	

HORIZONTAL OR VERTICAL (UP FLOW) INSTALLATION

Designed for maximum installation flexibility. The secondary drain (built-in) allows the unit to be mounted horizontally (sizes 06K-58K) or vertically (up flow) (sizes 06K-48K).

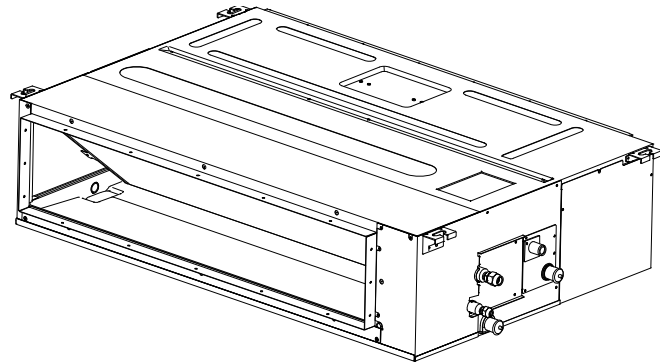

Fig. 3 – Unit mounted horizontally

A220735

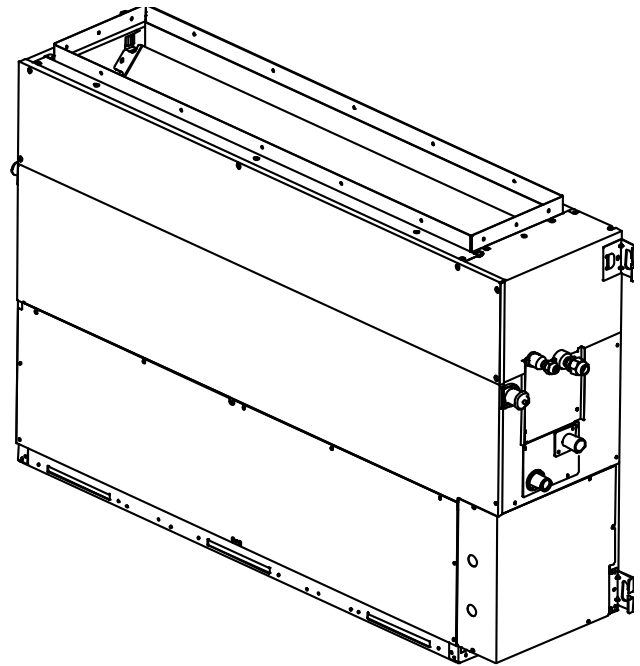

Fig. 4 – Unit mounted vertically (upflow)

A220736

OPTIONAL ACCESSORIES

ORDERING NO.	DESCRIPTION	FOR MODELS
KSACN1201AAA	Wired Controller for basic timer only operation	All Sizes
KSAIC0501230	24 volt interface for third party thermostats (GEN 3)	All Sizes
KSAIC0601230	24 volt interface for third party thermostats (MINI)	All Sizes
17401204010126	T1 Ambient Sensor Extension	All Sizes

DIMENSIONS

Low Static

Table 2 – Low Static

MODEL (KBTU/H)	UNIT	A	B	C	C1	D	E	F	G	H	I	J	K	L	M	H1	H2	W1	W2
06 09	mm	700	200	470	506	450	137	537	30	152	599	186	50	741	360	84	140	84	84
	inch	27.56	7.87	18.50	19.92	17.72	5.39	21.14	1.18	5.98	23.58	7.32	1.97	29.17	14.17	3.31	5.51	3.31	3.31
18	mm	880	210	634	674	600	140	706	50	136	782	190	50	920	508	78	148	88	112
	inch	34.65	8.27	24.96	26.54	23.62	5.51	27.80	1.97	5.35	30.79	7.48	1.97	36.22	20.00	3.07	5.83	3.46	4.41

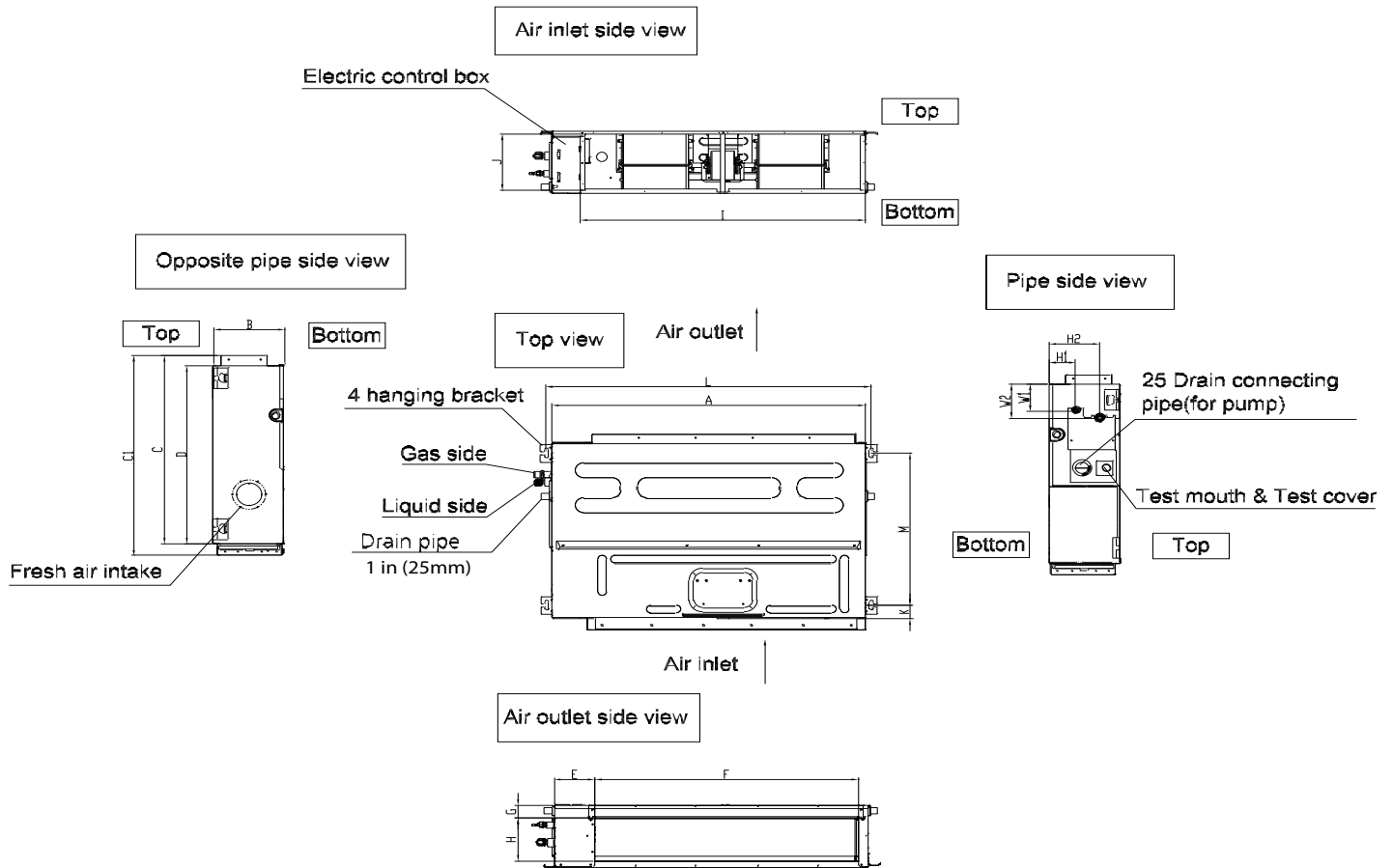

Fig. 5 – Size 06/09/12K

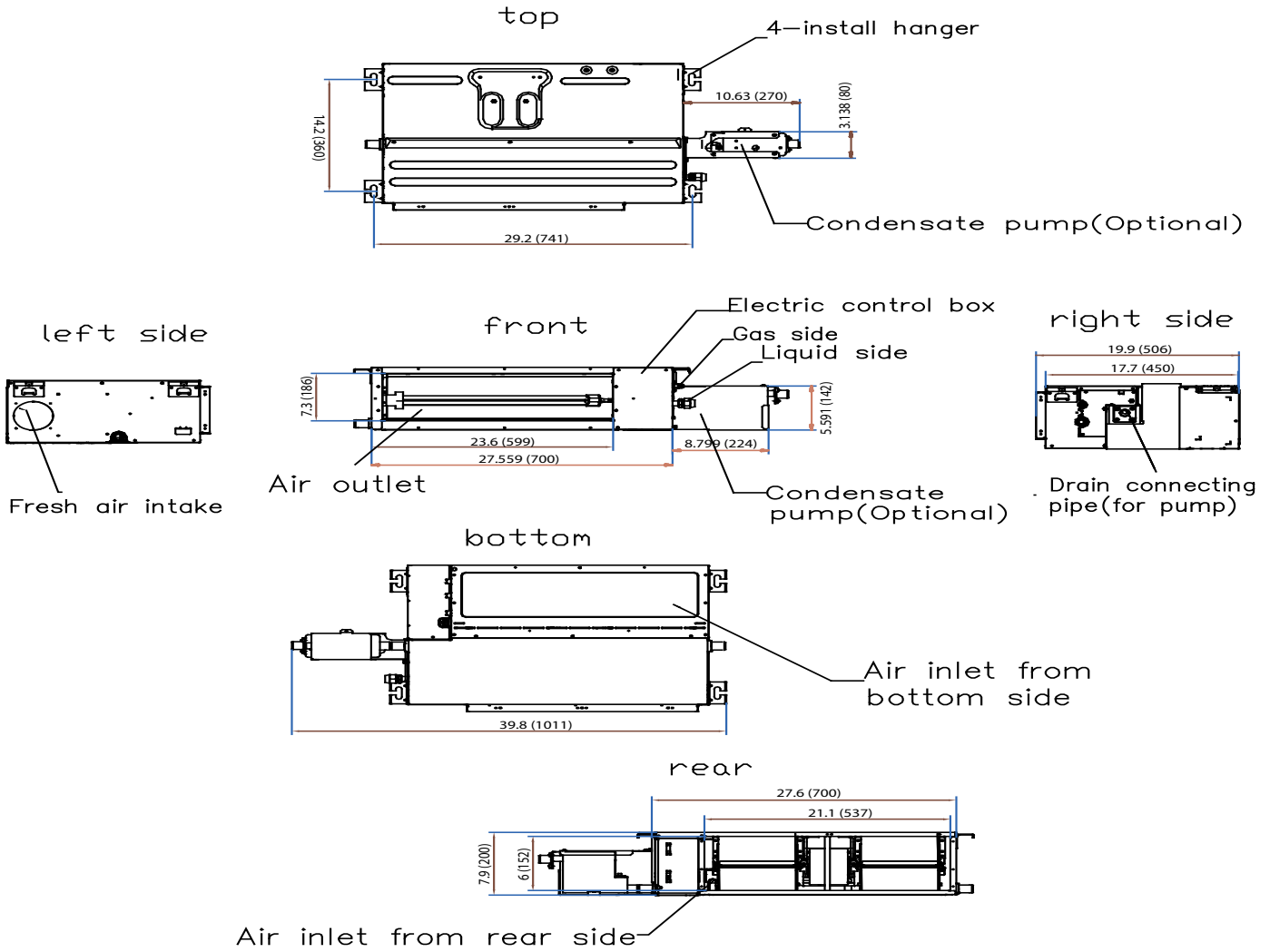

Fig. 6 – Size 06/09/12K with external condensate pump (optional) Low Static

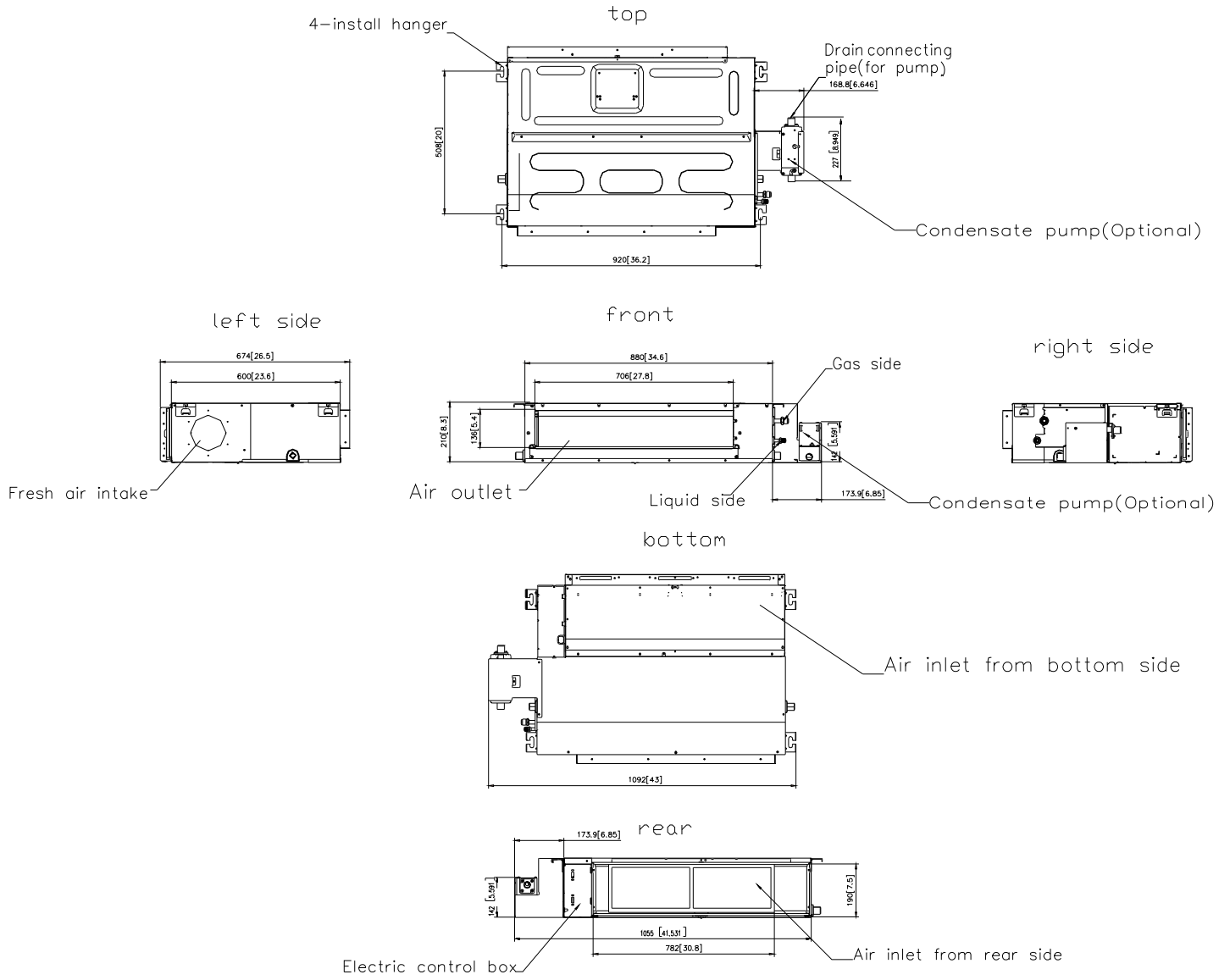

Fig. 7 – Size 18K with external condensate pump (optional) Low Static

High Static

Table 3 – Dimensions

MODEL	UNIT	OUTLINE DIMENSION				AIR OUTLET OPENING SIZE		AIR RETURN OPENING SIZE		SIZE OF MOUNTED LUG		FRESH AIR INTAKE OPENING SIZE	
		A	B	C	D	E	F	G	H	I	J	K	L
(KBtu/h)		A	B	C	D	E	F	G	H	I	J	K	L
06 09 12	mm	700	245	750	795	527	178	592	212	740	640	100	126
	inch	27.6	9.6	29.5	31.3	20.7	7.0	23.3	8.3	29.1	25.2	3.9	5.0
18	mm	1000	245	750	795	827	178	892	212	1040	640	100	126
24	inch	39.4	9.6	29.5	31.3	32.6	7.0	35.1	8.3	40.9	25.2	3.9	5.0
36 48	mm	1200	300	750	795	1027	233	1092	267	1240	640	125	160
	inch	47.2	11.8	29.5	31.3	40.4	9.2	43.0	10.5	48.8	25.2	4.9	6.3
58	mm	1400	380	800	845	1223	320	1272	330	1440	668	125	160
	inch	55.1	14.9	31.5	33.3	48.1	12.6	50.1	13.0	56.7	26.3	4.9	6.3

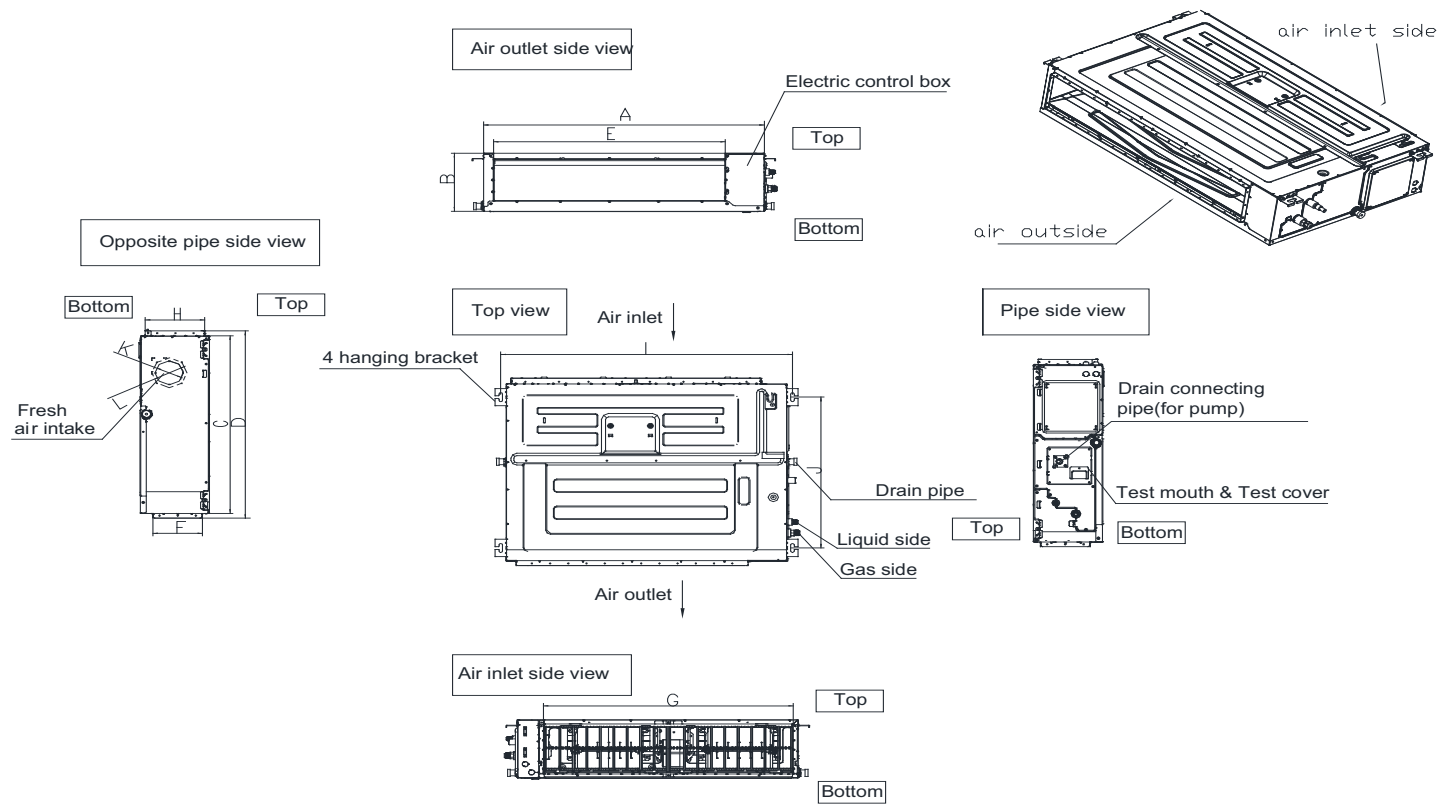

Fig. 8 – Sizes 9K/12K, 18K, 24K, 36K, 48K, 58K High Static

MAINTENANCE CLEARANCES

Maintenance clearances provide access for system inspections.

NOTE: Always follow local codes.

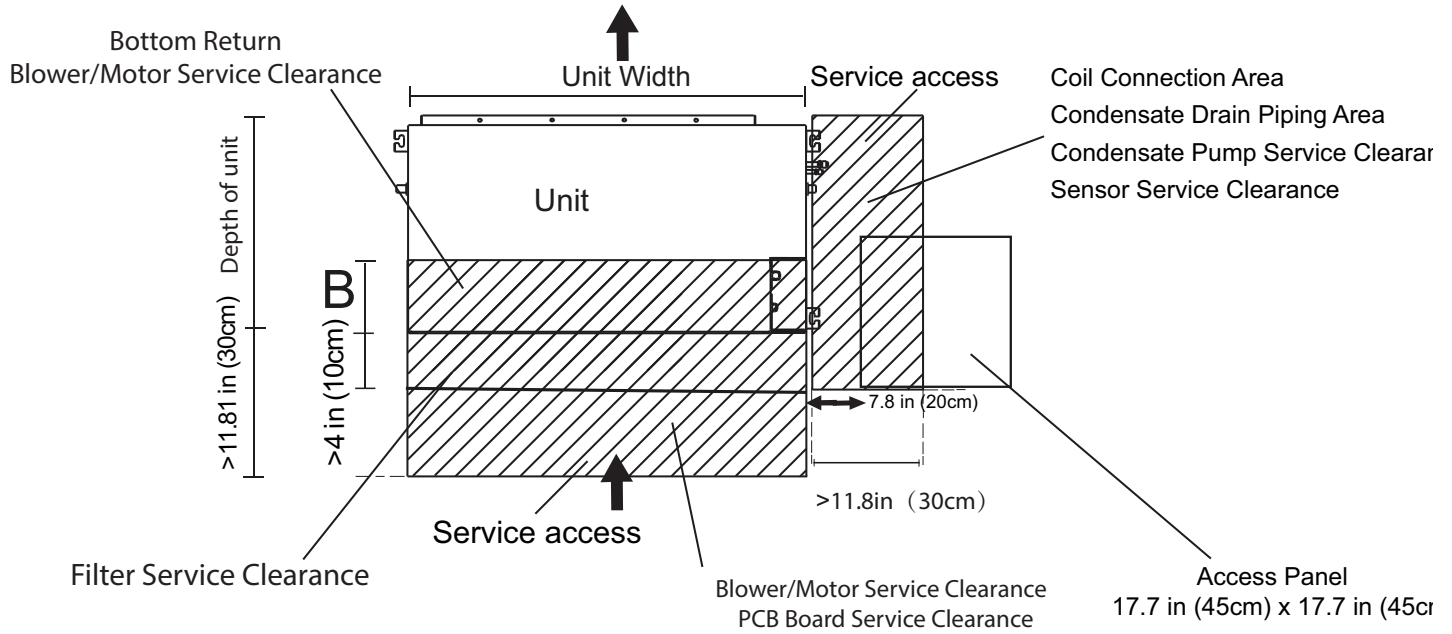

Fig. 9 – Maintenance Clearance

A220740

Capacity (Kbtu)	B
6K thru 36K	11.81in.(30cm)
48K, 58K	15.75in.(40cm)

NOTE: If installed above a fixed ceiling, utilize a ceiling access panel the length and width of the unit, otherwise the blower components and/or the entire unit cannot be removed.

If a single access panel is desired, the minimum dimensions should be:

- **Single Access Panel Width:** The width of the unit plus 2-inches on both sides
- **Single Access Panel Length:** The length of the unit plus 18-inches on the connection end and 2-inches on the opposite end.

SPECIFICATIONS (HIGH STATIC)

Table 4 – High Static Specifications

Size			9K/12K	18K	24K	36K	48K	58K
Indoor Model Number			45MBDAQ06XH3	45MBDAQ18XH3	45MBDAQ24XH3	45MBDAQ36XH3	45MBDAQ48XH3	45MBDAQ58XH3
Power supply		V;Ph;Hz	208/230V;1Ph;60HZ					
INDOOR FAN SPECIFICATIONS	Material		Galvanized sheet					
	Type		FLBJ-170*130*15-47	FLBJ-170*195*15-47	FLBJ-170*195*15-47	FLBJ-207*233*15-51	FLBJ-207*233*15-51	FLBJ-250*300*15-51
	Diameter	inch	6.7	6.7	6.7	8.1	8.1	9.8
		mm	170	170	170	207	207	250
	Height	inch	5.1	7.7	7.7	9.2	9.2	11.8
mm		130	195	195	233	233	300	
INDOOR MOTOR SPECIFICATIONS	Model		ZKFN-165-10-1L	ZKFN-165-10-1L	ZKFN-165-10-1L	ZKFN-400-8-1	ZKFN-560-8-4	ZKFN-560-8-4
	Type		DC	DC	DC	DC	DC	DC
	Input	W	185	185	185	302.8	515	515
	Max. input	W	263	263	263	427.3	665	665
	Output	W	165	165	165	400	560	560
	FLA	A	1.5	1.8	2.2	3.2	4	4
	Rated HP	HP	0.22	0.22	0.22	0.54	0.75	0.75
	Range of current	Amps	0.63 ±10%	0.63 ±10%	0.63 ±10%	2.45 ±10%	4 ±10%	4 ±10%
	Rated current	Amps	0.63	0.63	0.63	2.45	4	4
	Speed	rev/min	780 / 744 / 708	820 / 760 / 700	920 / 835 / 750	790 / 730 / 670	1000 / 950 / 880	853 / 778 / 702
	Rated RPM	rev/min	780	820	920	790	1000	853
	Insulation class		B					
	Safe class		IP20					
INDOOR REFRIGERANT COIL SPECIFICATIONS	Number of rows	Rows	3	3	3	4	4	4
	Tube outside dia.	inch	0.197	0.197	0.197	0.276	0.276	0.276
		mm	Φ5	Φ5	Φ5	Φ7	Φ7	Φ7
	Nominal Tube Wall	Inch (mm)	0.0079 (0.2)	0.0079 (0.2)	0.0079 (0.2)	0.0091 (0.23)	0.0091 (0.23)	0.0091 (0.23)
	Tube Enhancement	(Yes/No)	Yes	Yes	Yes	Yes	Yes	Yes
	Tube Material		Copper					
	Tube pitch(a)x row pitch(b)	inch	0.77 x 0.46	0.77 x 0.46	0.77 x 0.46	0.83 x 0.53	0.83 x 0.53	0.83 x 0.53
		mm	19.5 x 11.6	19.5 x 11.6	19.5 x 11.6	21 x 13.37	21 x 13.37	21 x 13.37
	Fin Spacing	FPI	22	22	22	19	19	20
		mm	1.2	1.2	1.2	1.4	1.4	1.3
	Fin type		Louvered					
	Fin Material		Gold hydrophilic aluminum					
	Coil length x height x width	inch	20.67 x 13.82 x 1.37	32.48 x 13.82 x 1.37	32.48 x 13.82 x 1.37	40.35 x 14.88 x 2.11	40.35 x 14.88 x 2.11	48.23 x 18.19 x 2.11
mm		525*351*34.8	825*351*34.8	825*351*34.8	1025*53.48*378	1025*53.48*378	1225*462*53.48	
Face area	ft2	1.98	3.12	3.12	4.17	4.17	6.09	
Number of circuits	#	6	9	9	9	9	11	

Manufacturer reserves the right to change, at any time, specifications and designs without notice and without obligations.

Table 4 – High Static Specifications (Continued)

Size			9K/12K	18K	24K	36K	48K	58K
SOUND DATA Indoor Sound Pressure Level dB(A)		Turbo	N/A	N/A	N/A	N/A	N/A	N/A
		Hi	32.5	36	40.0	45	51	52
		Med	30.5	34.0	37.0	40	46	48
		Lo	28.5	32.0	35	34	42	42
		Silent	26	28.0	29.5	31	40	41
CFM DATA Indoor air flow data		Turbo	419.08	706.32	853.47	1236.06	1648.08	2001.24
		Hi	350.22	618.03	706.32	1059.48	1471.50	1706.94
		Med	256.04	529.74	618.03	941.76	1294.92	1412.64
		Lo	216.02	441.45	500.31	765.18	1059.48	1118.34
		Silent	135.38	//	//	//	//	//
ENVIRONMENTAL SPECIFICATIONS	Cooling Operating Range Indoor Min - Max DB	°F	60~90	60~90	60~90	60~90	60~90	60~90
		(°C)	(16~32)	(16~32)	(16~32)	(16~32)	(16~32)	(16~32)
	Cooling Operating Range Indoor Min - Max WB	°F	59-84	59-84	59-84	59-84	59-84	59-84
		(°C)	(15-29)	(15-29)	(15-29)	(15-29)	(15-29)	(15-29)
	Heating Operating Range Indoor Min - Max DB	°F	32~86	32~86	32~86	32~86	32~86	32~86
		(°C)	(0~30)	(0~30)	(0~30)	(0~30)	(0~30)	(0~30)
	Non-operating environment Storage Temperature range (DB)	°F	-189	-189	-189	-189	-189	-189
		(°C)	(-45-60)	(-45-60)	(-45-60)	(-45-60)	(-45-60)	(-45-60)
	Operation Humidity	%	0-80	0-80	0-80	0-80	0-80	0-80
	Ambient Humidity	%	0-80	0-80	0-80	0-80	0-80	0-80

SPECIFICATIONS (LOW STATIC)

Table 5 – Low Static Specifications

SIZE			6K	09K/12K	18K	
INDOOR MODEL NUMBER			45MBDAQ06XA3	45MBDAQ12XA3	45MBDAQ18XA3	
POWER SUPPLY		V;Ph;Hz	208/230V;1Ph;60HZ	208/230V;1Ph;60HZ	208/230V;1Ph;60HZ	
INDOOR FAN SPECIFICATIONS	Material		PP+GF28	PP+GF28	ABS-GF10	
	Type		LX-143*107*15-41J	LX-143*107*15-41J	LX-154*158*15-41H	
	Diameter	inch	5.6	5.6	6.1	
		mm	143	143	154	
	Height	inch	4.2	4.2	6.2	
mm		107	107	158		
INDOOR MOTOR SPECIFICATIONS	Model		ZKFN-81-8-1	ZKFN-81-8-1	ZKFN-165-10-1L	
	Type		DC	DC	DC	
	Input	W	150	150	185	
	Max. input	W	171.5	171.5	263	
	Output	W	81	81	165	
	FLA	A	0.9	0.9	1.2	
	Rated HP	HP	0.11	0.11	0.22	
	Range of current	Amps	0.35 ±10%	0.35 ±10%	0.63 ±10%	
	Rated current	Amps	0.35	0.35	0.63	
	Speed	rev/min	1070 / 990 / 910	1070 / 990 / 910	1100 / 900 / 700	
	Rated RPM	rev/min	1070	1070	1100	
	Insulation class		B	B	B	
	Safe class		IP20	IP20	IP20	
INDOOR REFRIGERANT COIL SPECIFICATIONS	Number of rows	Rows	3	3	3	
	Tube outside dia.	inch	0.276	0.276	0.276	
		mm	Φ7	Φ7	Φ7	
	Nominal Tube Wall	Inch (mm)	0.00945 (0.24)	0.00945 (0.24)	0.00945 (0.24)	
	Tube Enhancement	(Yes/No)	Yes			
	Tube Material		Copper			
	Tube pitch (a) x row pitch (b)	inch	0.83 x 0.53	0.83 x 0.53	0.83 x 0.53	
		mm	21 x 13.37	21 x 13.37	21 x 13.37	
	Fin Spacing	FPI	18	18	18	
		mm	1.4	1.4	1.4	
	Fin type		Louvered	Louvered	Louvered	
	Fin Material		Gold hydrophilic aluminum			
	Coil length x height x width	inch	20.67 x 8.27 x 1.58	20.67 x 8.27 x 1.58	27.36 x 9.92 x 1.58	
mm		525 x 210 x 40.11	525 x 210 x 40.11	695 x 252 x 40.11		
Face area	ft ²	1.19	1.19	1.89		
Number of circuits	#	3	3	4		
ENVIRONMENTAL SPECIFICATIONS	Cooling Operating Range	Indoor Min - Max DB	°F	60~90	60~90	60~90
			(°C)	(16?32)	(16?32)	(16?32)
		Indoor Min - Max WB	°F	59-84	59-84	59-84
			(°C)	(15-29)	(15-29)	(15-29)
		Outdoor Min - Max DB	°F	-22~122	-22~122	-22~122
			(°C)	(-30~50)	(-30~50)	(-30~50)
	Heating Operating Range	Indoor Min - Max DB	°F	32~86	32~86	32~86
			(°C)	(0?30)	(0?30)	(0?30)
		Outdoor Min - Max DB	°F	-22~75	-22~75	-22~75
		(°C)	(-30~24)	(-30~24)	(-30~24)	
Non-operating environment Storage Temperature range (DB)		°F	-189	-189	-189	
	(°C)	(-45-60)	(-45-60)	(-45-60)		
Operation Humidity		%	0-80	0-80	0-80	
Ambient Humidity		%	0-80	0-80	0-80	

APPLICATION DATA

UNIT SELECTION

Select equipment to either match or handle slightly less than the anticipated peak load. This provides better humidity control, fewer unit cycles, and less part-load operation.

For units used in spaces with high sensible loads, base equipment selection on the unit sensible load, not on the total anticipated load. Adjust for anticipated room wet bulb temperature to avoid undersizing the equipment.

UNIT MOUNTING (INDOOR)

NOTE: Follow local codes.

Refer to unit Installation Instructions for further details.

Unit leveling - For reliable operation, units should be level in all planes.

Clearance - Provide adequate clearance for airflow (Fig. 9).

Unit location - Select a location which provides the best air circulation for the room.

These units should be positioned as accessible as possible above the ceiling. The unit return and discharge should not be obstructed by furniture, curtains, or anything which may cause unit short cycling or air recirculation.

Duct the unit in the middle of the selected wall (if possible). Duct towards an outside wall, if available, to make piping easier, and position the unit so it faces the normal location of room occupants.

UNIT MOUNTING (OUTDOOR)

Refer to the unit's Installation Instructions for further details.

DO NOT install the indoor or outdoor units in a location with special environmental conditions. For those applications, contact your ductless representative.

MOUNTING TEMPLATE

Refer to the unit's installation instructions for further details.

SUPPORT

Adequate support must be provided to support the weight of all fan coils. Refer to the base unit dimensional drawings which contain the location of the mounting brackets.

SYSTEM OPERATING CONDITIONS

OPERATING RANGE Min/Max °F (°C)		
	Cooling	Heating
Indoor DB	63 / 90 (17 / 32)	32 / 86 (0 / 30)
Indoor WB	59 / 84 (15 / 29)	-

NOTE: Reference the unit's installation instructions for more information.

DRAIN CONNECTIONS

Install drains to meet the local sanitation codes. The in-ceiling cassette is supplied with a condensate lift pump that is capable of lifting the water 29.5in (750mm) above the top of the unit. A downward sloped condensate drain pipe can be used to dispose of water.

WIRING

All wires must be sized per NEC (National Electrical Code) or CEC (Canadian Electrical Code) and local codes. Use the Electrical Data table MCA (minimum circuit amps) and MOCP (maximum over current protection) to correctly size the wires and the disconnect fuse or breakers respectively.

SIZES 06-24 RECOMMENDED CONNECTION METHOD FOR POWER AND COMMUNICATION WIRING

Power and Communication Wiring: The main power is supplied to the outdoor unit. The field supplied 14/3 power/ communication wiring, from the outdoor unit to the indoor unit, consists of four (4) wires and provides the power for the indoor unit. Two wires are high voltage AC power, one is communication wiring and the other is a ground wire.

To minimize communication interference: If installed in a high Electromagnetic field (EMF) area and communication issues arise, a 14/2 stranded shielded wire can be used to replace L2 and (S) between the outdoor and indoor units - landing the shield onto the ground in the outdoor unit only.

Wiring Sizes 06-24

Cable	Cable Size	Remarks
Connection Cable	14AWG	3 wire + Ground 1Φ 208/230 V (Stranded wire is recommended)

SIZES 36-58 RECOMMENDED CONNECTION METHOD FOR POWER AND COMMUNICATION WIRING

Power and Communication Wiring: The main power is supplied to the outdoor unit. The field supplied power wiring from the outdoor unit to the indoor unit consists of three (3) wires and provides the power for the indoor unit. Two wires are high voltage AC power and one is a ground wire. To minimize voltage drop, the factory recommended wire size is 14/2 stranded with a ground.

Communication Wiring: A separate shielded stranded copper conductor only, with a 600 volt rating and double insulated copper wire, must be used as the communication wire from the outdoor unit to the indoor unit.

Please use a separate shielded 16GA stranded control wire.

Wiring Sizes 36-58

Cable	Cable Size	Remarks
Connection Cable	14AWG	2 wire + Ground 1Φ 208/230V
Communication Cable	16AWG	2 wire stranded shielded control wire

CONNECTION LABELS - HIGH STATIC

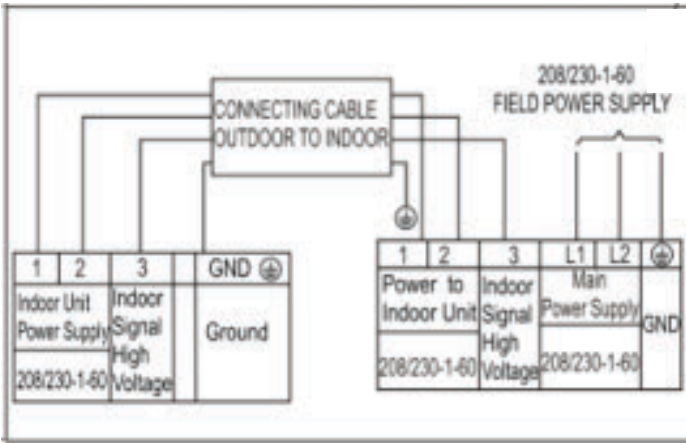

Fig. 10 – 9K/12K, 18K, 24K Connection Label

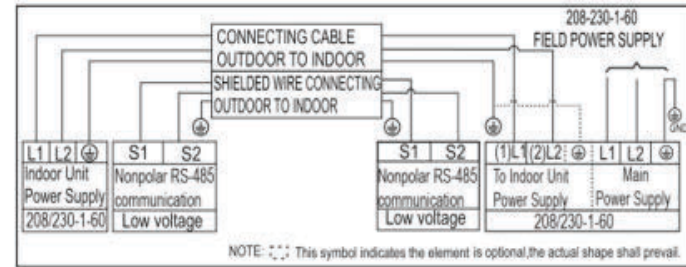

Fig. 11 – 36K Connection Label

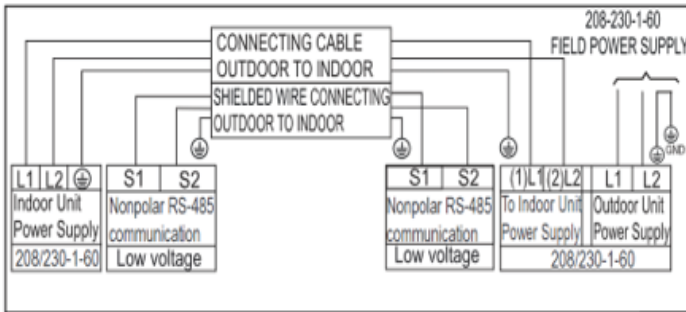

Fig. 12 – 48K, 60K Connection Label

CONNECTION LABELS - LOW STATIC

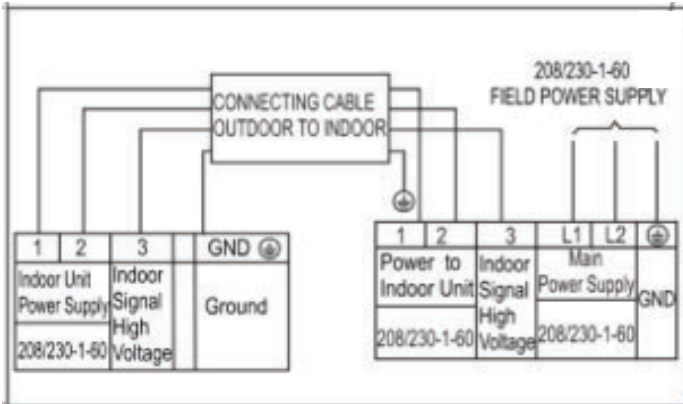

Fig. 13 – 6K, 9K/12K, 18K Connection Label

! CAUTION

EQUIPMENT DAMAGE HAZARD

Failure to follow this caution may result in equipment damage or improper operation.

Wires should be sized based on NEC and local codes.

! CAUTION

EQUIPMENT DAMAGE HAZARD

Failure to follow this caution may result in equipment damage or improper operation.

Be sure to comply with local codes while running wire from the indoor unit to the outdoor unit.

Every wire must be connected firmly. Loose wiring may cause the terminal to overheat or result in unit malfunction. A fire hazard may also exist. Ensure all wiring is tightly connected.

No wire should touch the refrigerant tubing, compressor or any moving parts.

Disconnecting means must be provided and shall be located within sight and readily accessible from the air conditioner.

Connecting cable with conduit shall be routed through the hole in the conduit panel.

WIRING CONNECTIONS

System Size	9K/12K	18K	24K	36K	48K	58K
V-Ph-Hz	208/230-1-60					
Power Supply	3Wires: includes ground wire (Outdoor); 208/230V-1Ph-60Hz					
Interconnection to Indoor Unit	Yes					
Shielded Wire (Yes/No)	Optional			Yes		

ELECTRICAL DATA

System Size		9K/12K	18K	24K	36K	48K	58K
Power Supply	V-Ph-Hz	208/230-1-60					
Minimum Circuit Ampacity (MCA)	A	3	3	3	3	3	3
Maximum Overcurrent Protection Ampacity (MOPA)	A	15	15	15	15	15	15

CONTROL SYSTEM

The indoor unit is equipped with a microprocessor control to perform two functions:

1. Provide safety for the system
2. Control the system and provide optimum levels of comfort and efficiency.

The main microprocessor is located on the control board of the fan coil unit (outdoor units have a microprocessor also) with thermistors located in the fan coil air inlet and on the indoor coil. Heat pump units have a thermistor on the outdoor coil. These thermistors monitor the system's operation to keep the unit within acceptable parameters and control the operating mode.

WIRELESS REMOTE CONTROLLER

1. A wireless remote control is supplied for system operation of all ducted units.
2. Each battery operated wireless (infrared) remote control may be used to control more than one unit.

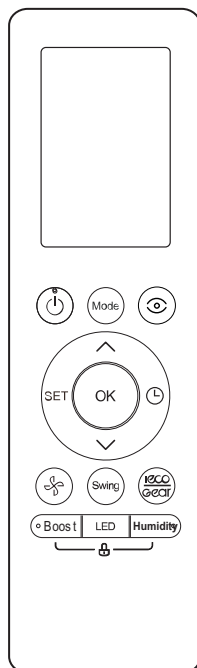

Fig. 14 – Wireless Remote Controller

WIRED REMOTE CONTROLLER

P/N KSACN1401AAA (included with the Unit)

1. Wired remote controller used for system operation of all ducted units.
2. Kit includes a wired remote controller but requires 16AWG or 18AWG stranded/shielded cable (field provided) for connecting the wired controller to this product. Refer to the KSACN1401AAA installation manual for complete instructions.
3. Connect the Ha/Hb wire terminals between the remote controller and the indoor unit.
4. Display in °F or °C and increments every 1°F or every 1°C.



Fig. 15 – KSACN1401AAA

24V INTERFACE (OPTIONAL)

Allows the ductless system to be controlled using a third-party thermostat:

- KSAIC0501230 (GEN 3)
- KSAIC0601230 (MINI)

SMART PHONE CONTROL (OPTIONAL)

A Wi-Fi® Kit used for system operation of all ducted units through a smart phone is available.

AIR FLOW DATA

Refer to “SPECIFICATIONS (HIGH STATIC)” on page 12 or

“SPECIFICATIONS (low Static)” on page 14.

SOUND PRESSURE

Refer to “SPECIFICATIONS (HIGH STATIC)” on page 12 or “SPECIFICATIONS (low Static)” on page 14.

FAN AND MOTOR SPECIFICATIONS

Refer to “SPECIFICATIONS (HIGH STATIC)” on page 12 or “SPECIFICATIONS (low Static)” on page 14.

SOUND PRESSURE TESTING METHOD

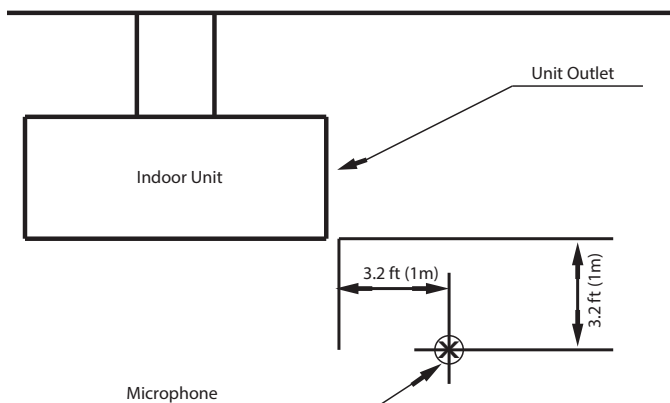

Fig. 16 – Sound Pressure Testing Method

USING THE KSACN1401AAA WIRED CONTROLLER

To Set Static Pressure Air Flow

The factory default setting is SP1, The external static pressure can be

FAN PERFORMANCES AT VARYING STATIC PRESSURES

The factory default setting is SP1. Airflows and fan curves applicable starting on production of Week 28 Year 2020 (Serial Number 2820V10001). For previous serial numbers refer to previous revision of this document.

Low Static

Table 6 – 06K/09K

		CFM (In.wc)	0	0.04	0.08	0.1	0.12	0.16	0.2	0.24	0.28	0.3	0.32	0.36	0.4	
		06K/09K	SP4	Turbo										446	421	370
H												404	373	313	260	
M													358	324	265	214
L													315	278	208	141
SP3	Turbo									445	404	361	335			
	H									381	339	293	270			
	M									333	285	242	218			
	L									271	220	170	148			
SP2	Turbo					430	412	374	340							
	H					374	353	311	271							
	M					318	297	258	213							
	L					267	242	204	153							
SP1	Turbo		402	365	326	307										
	H		365	326	282	262										
	M		330	286	241	214										
	L		286	238	185	161										

manually changed to the fan curves 1,2,3,4,5,6,7,8.

- Press and hold **Copy** for approximately 3 seconds. The lower right corner displays **P:00**, Press **OK**.
- Press “**^**” to scroll through the menu. The lower right corner shows **SP**, Press **OK**.
- Press “**^**” or “**v**” to scroll through the menu and select 1-8, Press **OK**.
- Press “**Back**” to exit the test mode.

To Set Real-Time Constant Air Flow

Use the Automatic Airflow “AF” Adjustment function to realize Real-time constant airflows.

- Press and hold **Copy** for approximately 3 seconds. The lower right corner shows **P:00**, Press “**OK**”.
- Press “**^**” to scroll through the menu. The lower right corner shows **AF**. Press “**OK**”.
- Press “**Back**” to exit the test mode.

NOTE: T1, T2, T2b, T3, T4 are sub-menus for thermistors. DO NOT select to set the external static pressure.

NOTE: Before commissioning, check the power connection of the machine, turn on the power, and keep the machine not working.

NOTE: If there is no change after airflow adjustment, perform the setting again.

NOTE: Setting Static Pressure or Automatic Airflow need to use the Wired Remote Controller.

NOTE: Low static pressure series 06K, 09K, 12K, 18K models, SP options can only be “1~4”.

Table 7 – 12K

12K		CFM (In.wc)	0	0.04	0.08	0.1	0.12	0.16	0.2	0.24	0.28	0.3	0.32	0.36	0.4	
		SP4	Turbo											521	489	437
	H											466	434	376	318	
	M											418	378	312	261	
	L											373	325	249	183	
	SP3	Turbo								544	489	431	397			
	H								489	431	371	336				
	M								450	388	314	268				
	L								398	331	245	190				
	SP2	Turbo				527	497	447	393							
	H				460	433	380	330								
	M				412	378	324	271								
	L				358	330	262	181								
	SP1	Turbo	490	461	428	408										
	H	426	384	343	318											
	M	374	327	285	260											
L	320	260	202	173												

Table 8 – 18K

18K		CFM (In.wc)	0	0.04	0.08	0.1	0.12	0.16	0.2	0.24	0.28	0.3	0.32	0.36	0.4	
		SP4	Turbo											686	669	638
	H											636	618	586	555	
	M											580	565	532	498	
	L											520	496	462	421	
	SP3	Turbo								678	650	620	612			
	H								627	591	563	553				
	M								571	537	509	500				
	L								513	480	450	438				
	SP2	Turbo				724	690	642	603							
	H				662	631	584	556								
	M				611	581	536	504								
	L				554	525	484	452								
	SP1	Turbo	692	647	603	582										
	H	613	566	523	494											
	M	550	514	465	443											
L	496	459	418	397												

<300 CFM >450 CFM - Airflow below 300 CFM or above 450 cfm/ton

High Static

Table 9 – 09K

		CFM (In.wc)	0	0.04	0.08	0.1	0.12	0.16	0.2	0.24	0.28	0.3	0.32	0.36	0.4	0.44	0.48	0.5	0.52	0.56	0.6	0.64	0.68	0.7	0.72	0.76	0.8			
09K	SP8	Turbo																							434	403	368	348		
		H																								384	360	331	316	
		M																									334	305	274	254
		L																									270	225	178	147
	SP7	Turbo																				460	415	370	346					
		H																				389	354	322	295					
		M																				325	298	271	244					
		L																				277	237	196	149					
	SP6	Turbo																	450	427	391	356								
		H																	398	377	343	305								
		M																	326	303	262	234								
		L																	283	254	202	153								
	SP5	Turbo														483	437	391	368											
		H														391	357	324	306											
		M														337	288	242	214											
		L														283	237	190	160											
	SP4	Turbo											478	454	405	361														
		H											406	385	348	303														
		M											361	342	305	256														
		L											300	278	237	174														
	SP3	Turbo							472	418	361	338																		
		H							404	354	308	287																		
		M							362	316	273	247																		
		L							300	266	220	172																		
	SP2	Turbo				468	448	409	354																					
		H				400	381	343	305																					
		M				348	330	297	260																					
		L				292	271	234	200																					
SP1	Turbo	441	406	370	353																									
	H	403	366	327	306																									
	M	377	330	283	265																									
	L	338	290	234	206																									

High Static (CONT)

Table 10 – 12K

		CFM (In.wc)	0	0.04	0.08	0.1	0.12	0.16	0.2	0.24	0.28	0.3	0.32	0.36	0.4	0.44	0.48	0.5	0.52	0.56	0.6	0.64	0.68	0.7	0.72	0.76	0.8			
12K	SP8	Turbo																							500	477	445	414		
		H																								459	432	401	374	
		M																								407	380	353	334	
		L																								353	334	290	242	
	SP7	Turbo																				624	541	461	426					
		H																				560	490	418	370					
		M																				500	436	366	317					
		L																				421	356	285	243					
	SP6	Turbo																	607	574	501	447								
		H																	484	465	427	383								
		M																	401	380	350	327								
		L																	332	307	271	242								
	SP5	Turbo														603	543	483	456											
		H														549	485	431	394											
		M														484	420	356	322											
		L														407	347	284	248											
	SP4	Turbo										615	584	516	456															
		H										556	521	456	387															
		M										507	472	393	321															
		L										454	418	337	278															
	SP3	Turbo								647	562	474	427																	
		H								559	483	415	380																	
		M								504	426	347	303																	
		L								438	376	297	247																	
	SP2	Turbo				566	541	489	426																					
		H				531	509	441	371																					
		M				490	464	396	307																					
		L				438	407	339	250																					
SP1	Turbo	489	457	428	411																									
	H	441	402	360	338																									
	M	408	356	307	284																									
	L	372	312	248	230																									

High Static (CONT)

Table 11 – 18K

		CFM (In.wc)	0	0.04	0.08	0.1	0.12	0.16	0.2	0.24	0.28	0.3	0.32	0.36	0.4	0.44	0.48	0.5	0.52	0.56	0.6	0.64	0.68	0.7	0.72	0.76	0.8			
18K	SP8	Turbo																							910	863	782	700		
		H																								849	808	722	636	
		M																								763	723	614	486	
		L																								707	657	543	425	
	SP7	Turbo																				918	828	725	677					
		H																				823	739	653	610					
		M																				769	684	590	536					
		L																				669	609	531	463					
	SP6	Turbo																	918	881	782	683								
		H																	825	793	707	609								
		M																	733	700	621	543								
		L																	646	614	545	445								
	SP5	Turbo														918	831	735	692											
		H														876	768	655	606											
		M														813	707	602	534											
		L														726	634	546	465											
SP4	Turbo											926	892	810	735															
	H											877	829	723	619															
	M											795	744	637	519															
	L											696	644	538	424															
SP3	Turbo								890	842	776	742																		
	H								838	758	677	639																		
	M								776	680	586	535																		
	L								672	578	491	438																		
SP2	Turbo				856	830	783	718																						
	H				805	778	725	641																						
	M				738	703	625	534																						
	L				434	414	368	315																						
SP1	Turbo	820	776	737	707																									
	H	711	676	616	577																									
	M	645	600	537	488																									
	L	574	524	465	426																									

High Static (CONT)

Table 12 – 24K

		CFM (In.wc)	0	0.04	0.08	0.1	0.12	0.16	0.2	0.24	0.28	0.3	0.32	0.36	0.4	0.44	0.48	0.5	0.52	0.56	0.6	0.64	0.68	0.7	0.72	0.76	0.8				
		24K		SP8	Turbo																						1008	975	904	855	
H																											866	831	780	716	
M																												773	735	673	606
L																												680	639	549	486
SP7	Turbo																						1024	968	902	877					
	H																						889	836	786	759					
	M																						786	731	678	647					
	L																						657	609	531	463					
SP6	Turbo																			1008	972	908	845								
	H																			890	858	790	735								
	M																			780	743	686	622								
	L																			682	661	569	510								
SP5	Turbo															1022	952	882	855												
	H															935	861	784	729												
	M															840	758	678	634												
	L															749	650	556	519												
SP4	Turbo													1008	965	904	839														
	H													916	886	829	753														
	M													846	808	724	624														
	L													766	720	637	522														
SP3	Turbo								1001	909	846	810																			
	H								898	832	757	731																			
	M								843	773	691	652																			
	L								719	660	589	527																			
SP2	Turbo				996	951	883	832																							
	H				893	863	801	746																							
	M				801	776	713	644																							
	L				697	672	593	496																							
SP1	Turbo	998	929	863	827																										
	H	891	811	742	715																										
	M	762	692	614	588																										
	L	633	572	497	461																										

High Static (CONT)

Table 13 – 36K

36K	CFM (In.wc)	0	0.06	0.12	0.148	0.16	0.2	0.22	0.24	0.28	0.3	0.32	0.36	0.4	0.44	0.48	0.5	0.52	0.56	0.6	0.64	0.68	0.7	0.72	0.76	0.8	
		SP8	Turbo																							1699	1621
H																								1595	1501	1374	1254
M																								1477	1383	1257	1137
L																								1342	1248	1121	1004
SP7	Turbo																				1642	1524	1410	1333			
H																					1503	1380	1248	1195			
M																					1354	1225	1112	1030			
L																					1237	1092	926	794			
SP6	Turbo																1570	1506	1418	1343							
H																	1442	1388	1298	1226							
M																	1295	1236	1151	1074							
L																	1107	1031	936	854							
SP5	Turbo													1629	1514	1387	1327										
H														1502	1398	1271	1189										
M														1413	1283	1160	1071										
L														1277	1165	1018	921										
SP4	Turbo										1548	1480	1392	1301													
H											1413	1366	1268	1185													
M											1260	1201	1112	1031													
L											1092	1030	924	856													
SP3	Turbo						1600		1501	1377	1311																
H						1453		1363	1228	1151																	
M						1295		1183	1059	992																	
L						1183		1071	942	873																	
SP2	Turbo			1552		1424	1308	1239																			
H				1436		1305	1161	1061																			
M				1330		1177	999	889																			
L				1189		1009	809	680																			
SP1	Turbo	1567	1464	1349	1268																						
H		1304	1192	1046	970																						
M		1062	930	798	732																						
L		898	727	584	515																						

High Static (CONT)

Table 14 – 48K

		CFM (In.wc)	0	0.06	0.12	0.18	0.2	0.24	0.28	0.3	0.32	0.36	0.4	0.44	0.48	0.5	0.52	0.56	0.6	0.64	0.68	0.7	0.72	0.76	0.8			
48K	SP8	Turbo																					2279	2161	1972	1779		
		H																						2020	1948	1793	1629	
		M																							1866	1751	1595	1423
		L																							1624	1569	1401	1184
	SP7	Turbo																		2226	2102	1913	1722					
		H																		2020	1901	1746	1547					
		M																		1836	1716	1566	1397					
		L																		1583	1474	1248	1057					
	SP6	Turbo															2126	2061	1919	1745								
		H															1932	1866	1746	1590								
		M															1713	1669	1566	1423								
		L															1507	1474	1366	1230								
	SP5	Turbo											2067	1978	1825	1710												
		H											1891	1807	1669	1567												
		M											1705	1651	1536	1423												
		L											1507	1457	1336	1230												
	SP4	Turbo									2032	1978	1856	1728														
		H									1861	1807	1699	1557														
		M									1705	1651	1554	1401														
		L									1507	1439	1324	1195														
	SP3	Turbo					3332	3120	2934	2828																		
		H					3050	2820	2652	2521																		
		M					2700	2462	2300	2170																		
		L					2416	2202	2040	1951																		
	SP2	Turbo	3410	3275	3110	2925	2862																					
		H	3120	2985	2840	2645	2547																					
		M	2776	2675	2510	2350	2278																					
		L	2482	2355	2185	2020	1960																					
SP1	Turbo	1960	1881	1783	1675	1637																						
	H	2820	2685	2520	2335	2272																						
	M	2562	2425	2260	2075	2010																						
	L	2272	2135	1970	1780	1720																						

High Static (CONT)

Table 15 – 58K

	CFM (In.wc)	0	0.04	0.08	0.12	0.16	0.2	0.24	0.28	0.3	0.32	0.36	0.4	0.44	0.48	0.5	0.52	0.56	0.6	0.64	0.68	0.7	0.72	0.76	0.8	
58K SP8	Turbo																						2484	2372	2107	1777
	H																						2203	2101	1848	1580
	M																						1985	1868	1609	1331
	L																						1784	1682	1420	1134
SP7	Turbo																		2472	2295	2107	1998				
	H																		2203	2026	1832	1699				
	M																		2038	1850	1567	1325				
	L																		1848	1599	1264	1024				
SP6	Turbo															2472	2390	2239	2069							
	H															2203	2134	1995	1858							
	M															2008	1953	1775	1519							
	L															1848	1710	1447	1279							
SP5	Turbo												2464	2331	2205	2129										
	H												2284	2154	2035	1958										
	M												2069	1952	1835	1739										
	L												1894	1743	1546	1325										
SP4	Turbo									2451	2390	2295	2182													
	H									2244	2191	2060	1897													
	M									2037	1947	1790	1650													
	L									1735	1655	1471	1203													
SP3	Turbo					2353	2267	2144	2067																	
	H					2149	2042	1907	1809																	
	M					1945	1798	1660	1573																	
	L					1696	1543	1360	1188																	
SP2	Turbo	2536	2447	2329	2225	2129	2012																			
	H	2370	2260	2147	2036	1926	1802																			
	M	2171	2060	1942	1825	1686	1533																			
	L	2014	1891	1773	1630	1480	1324																			
SP1	Turbo	2473	2367	2277	2178	2070	1961																			
	H	2167	2058	1949	1822	1709	1530																			
	M	2035	1912	1793	1677	1516	1366																			
	L	1899	1772	1648	1507	1338	1138																			

<300 CFM >450 CFM - Airflow below 300 CFM or above 450 cfm/ton

FAN PERFORMANCES AT VARYING STATIC PRESSURES — LOW STATIC

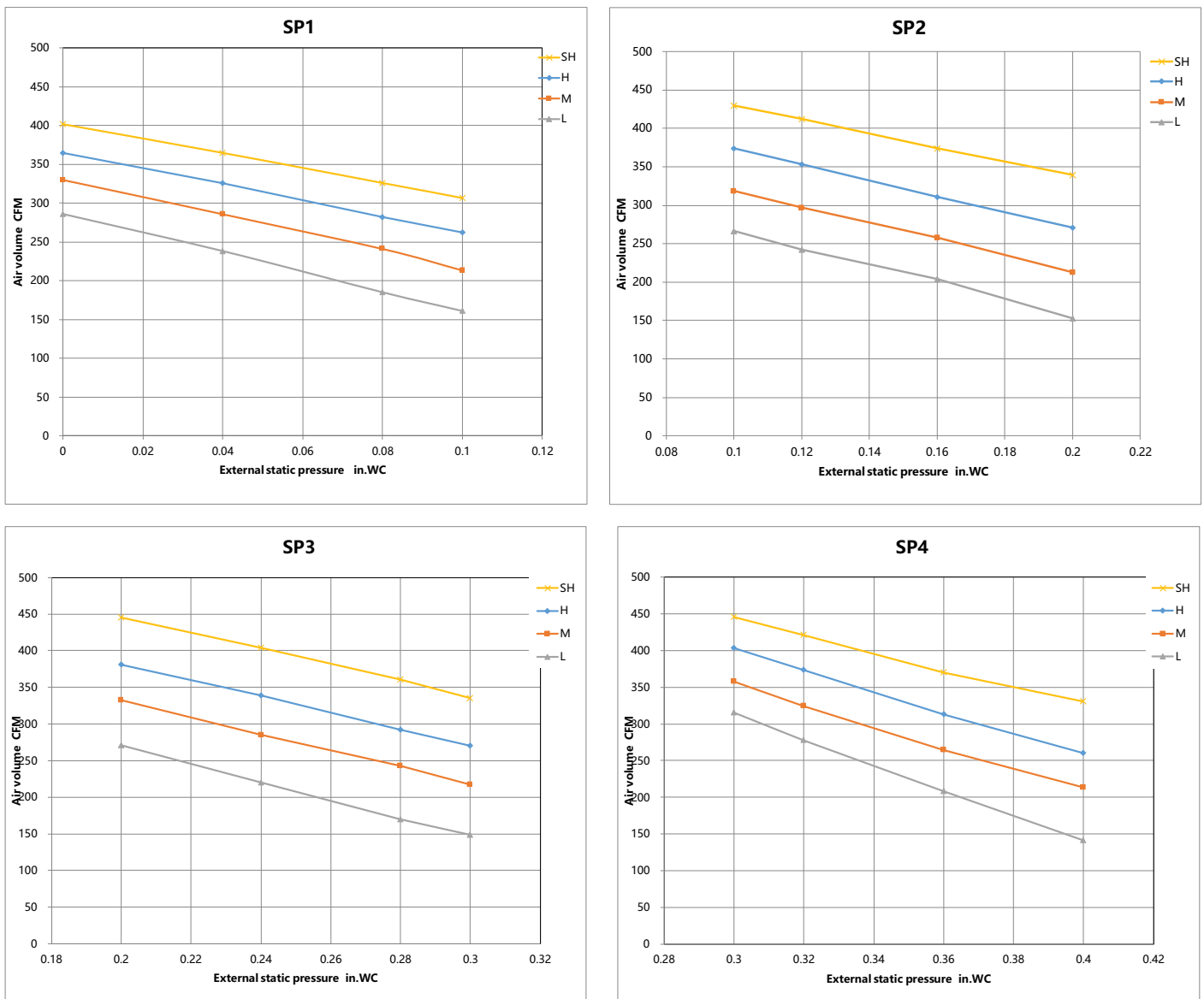

Fig. 17 – Low Static Pressure Curves – 6/9k

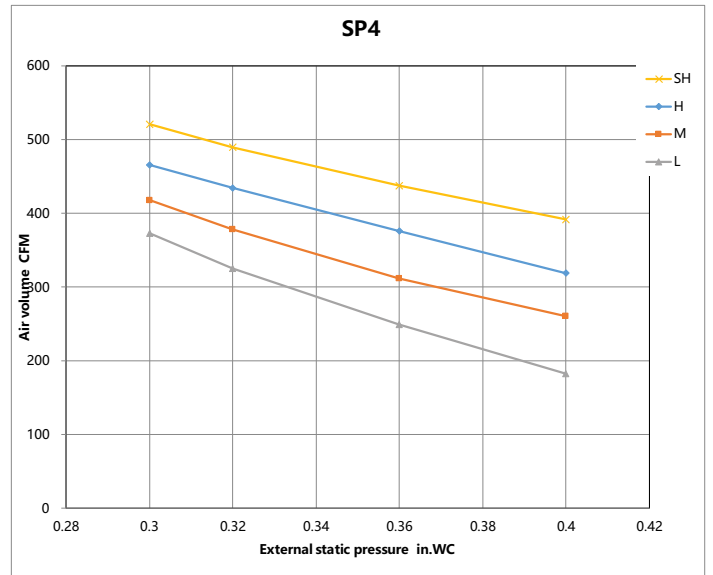
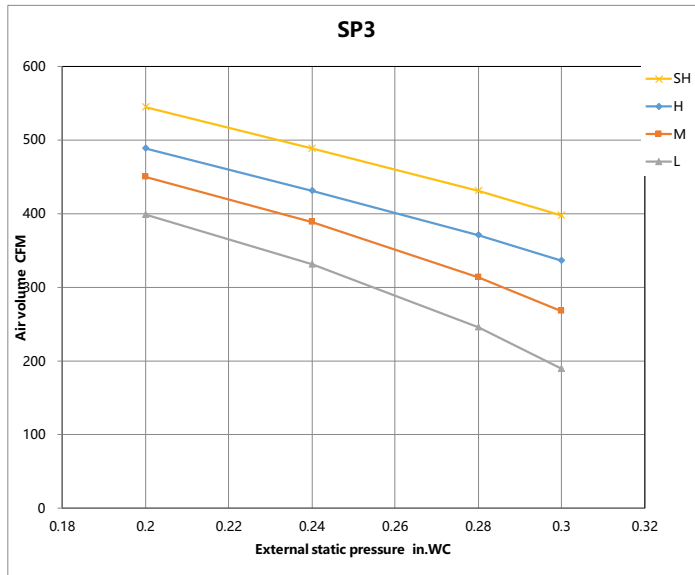
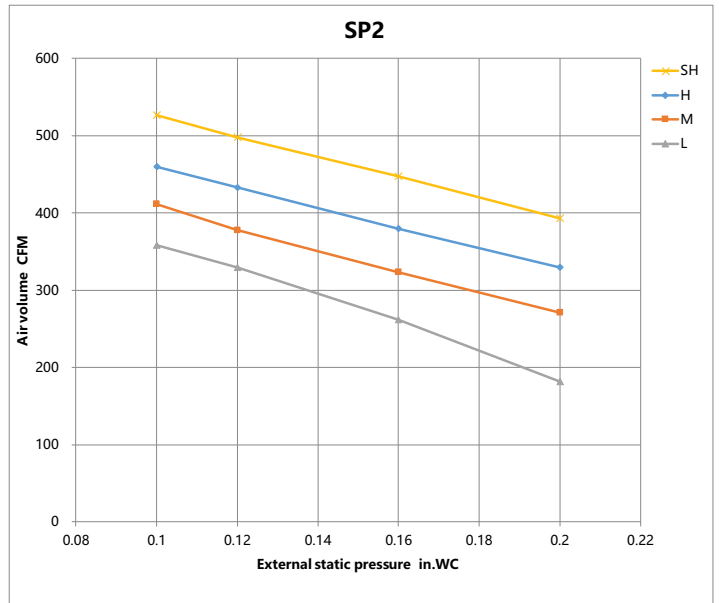
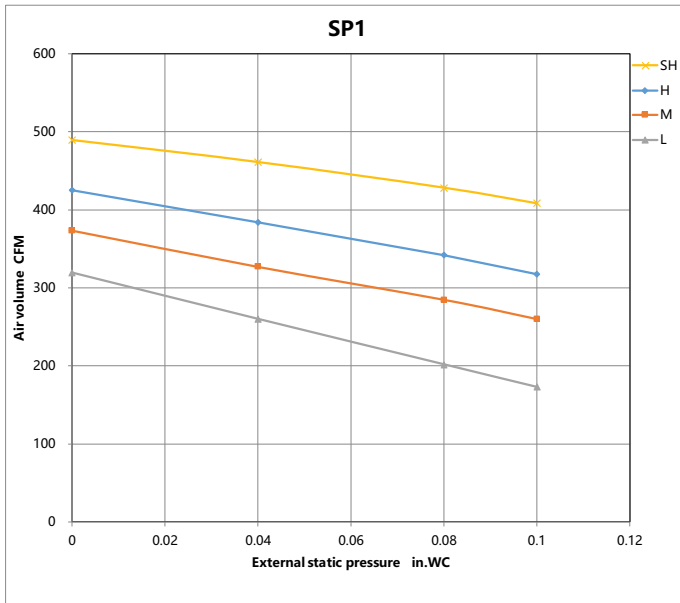

Fig. 18 – Low Static Pressure Curves – 12k

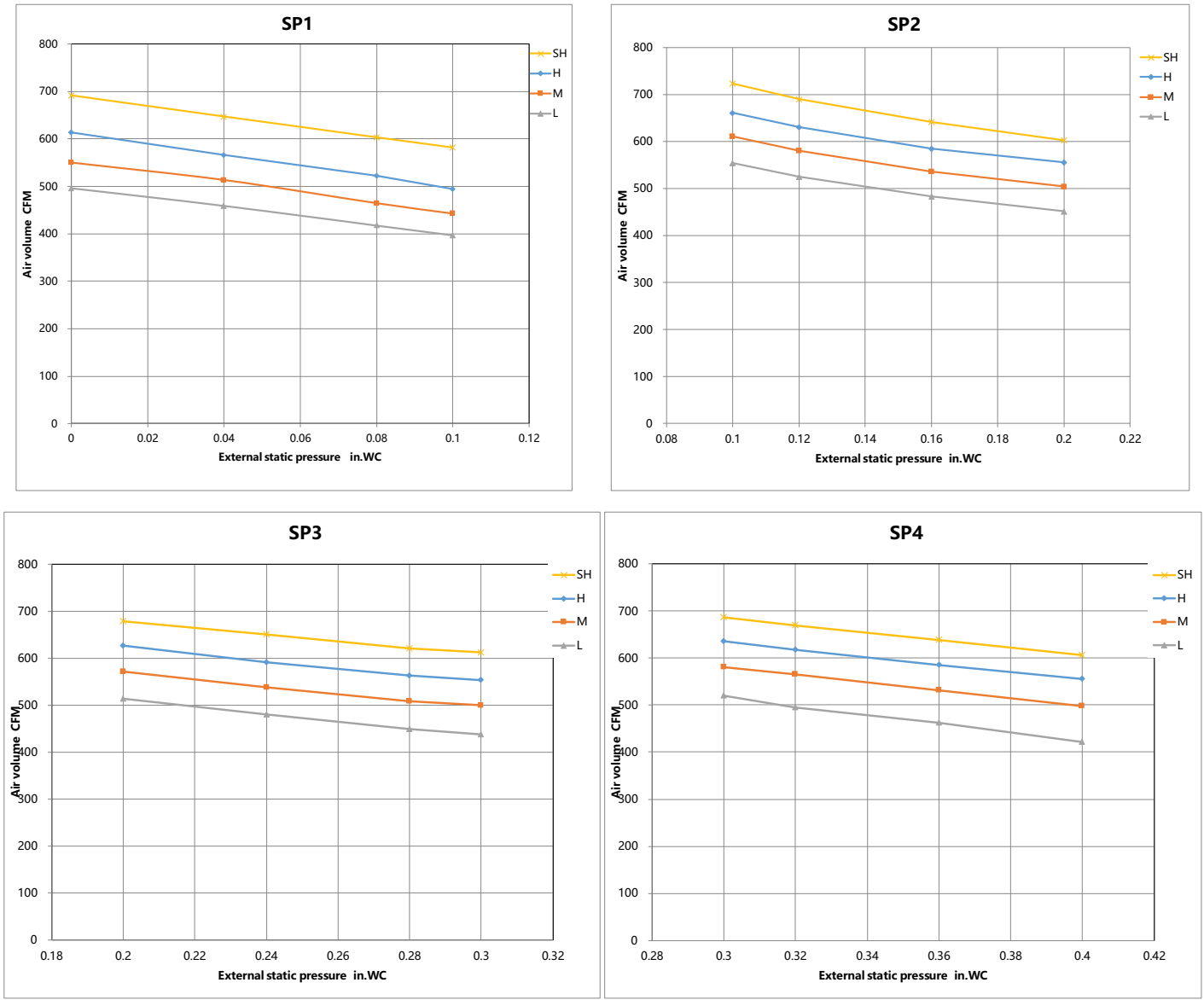
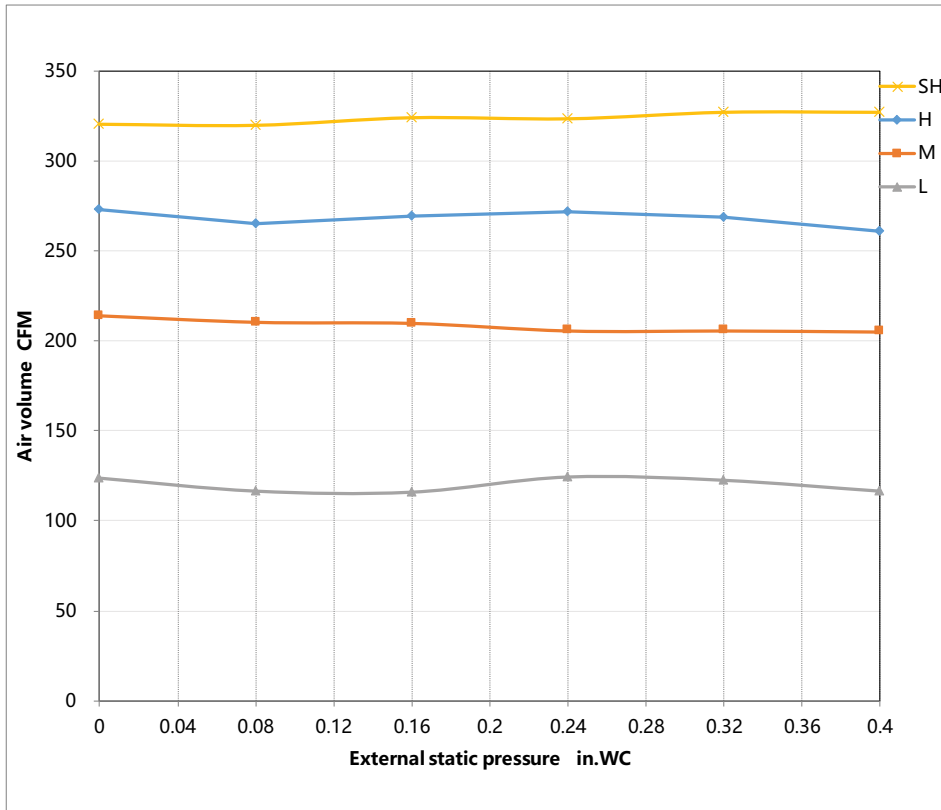

Fig. 19 – Low Static Pressure Curves – 18k

6k/9k



12k

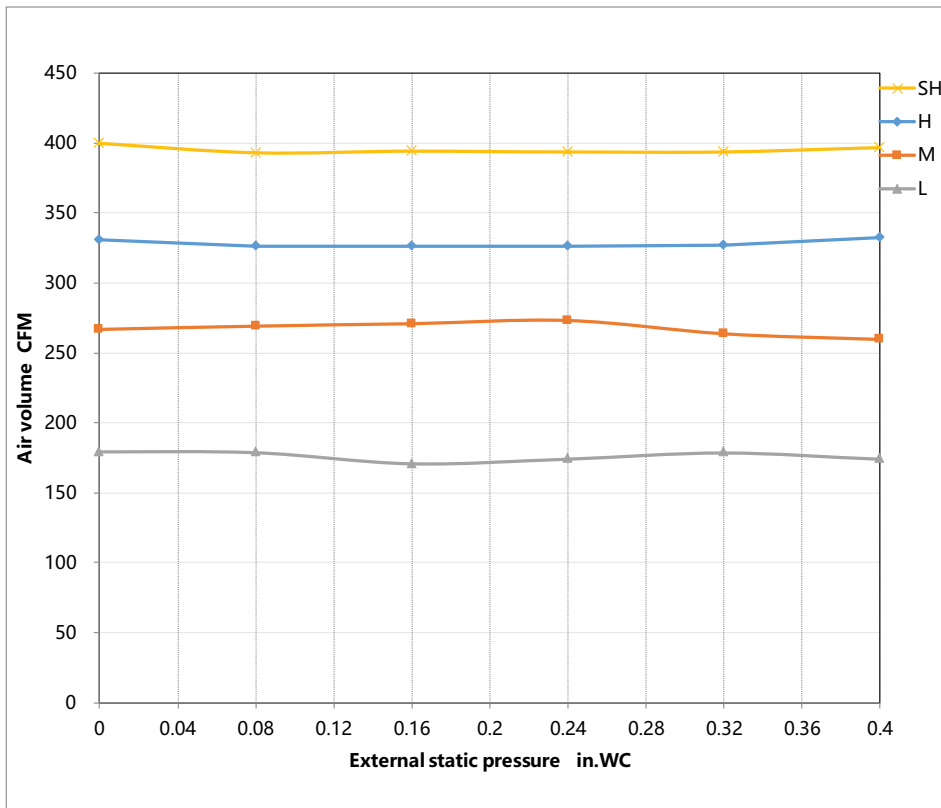

Fig. 20 – Low Static Pressure Curves – Constant Air Volume

18k

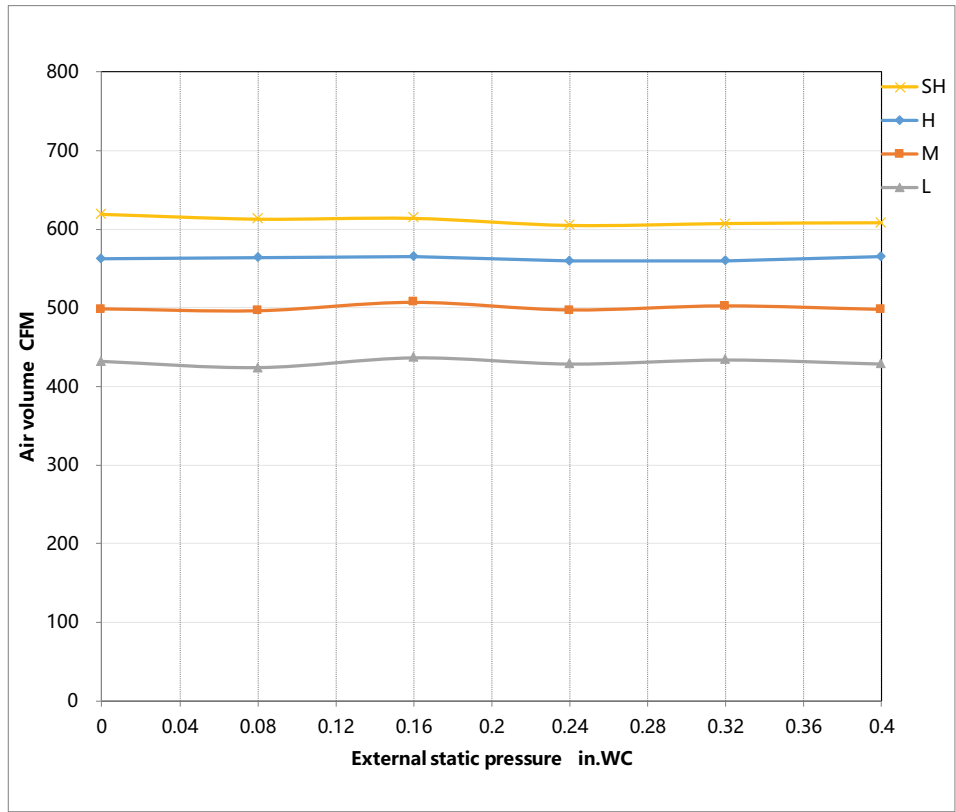

Fig. 21 – Low Static Pressure Curves – Constant Air Volume

FAN PERFORMANCES AT VARYING STATIC PRESSURES — HIGH STATIC

9k

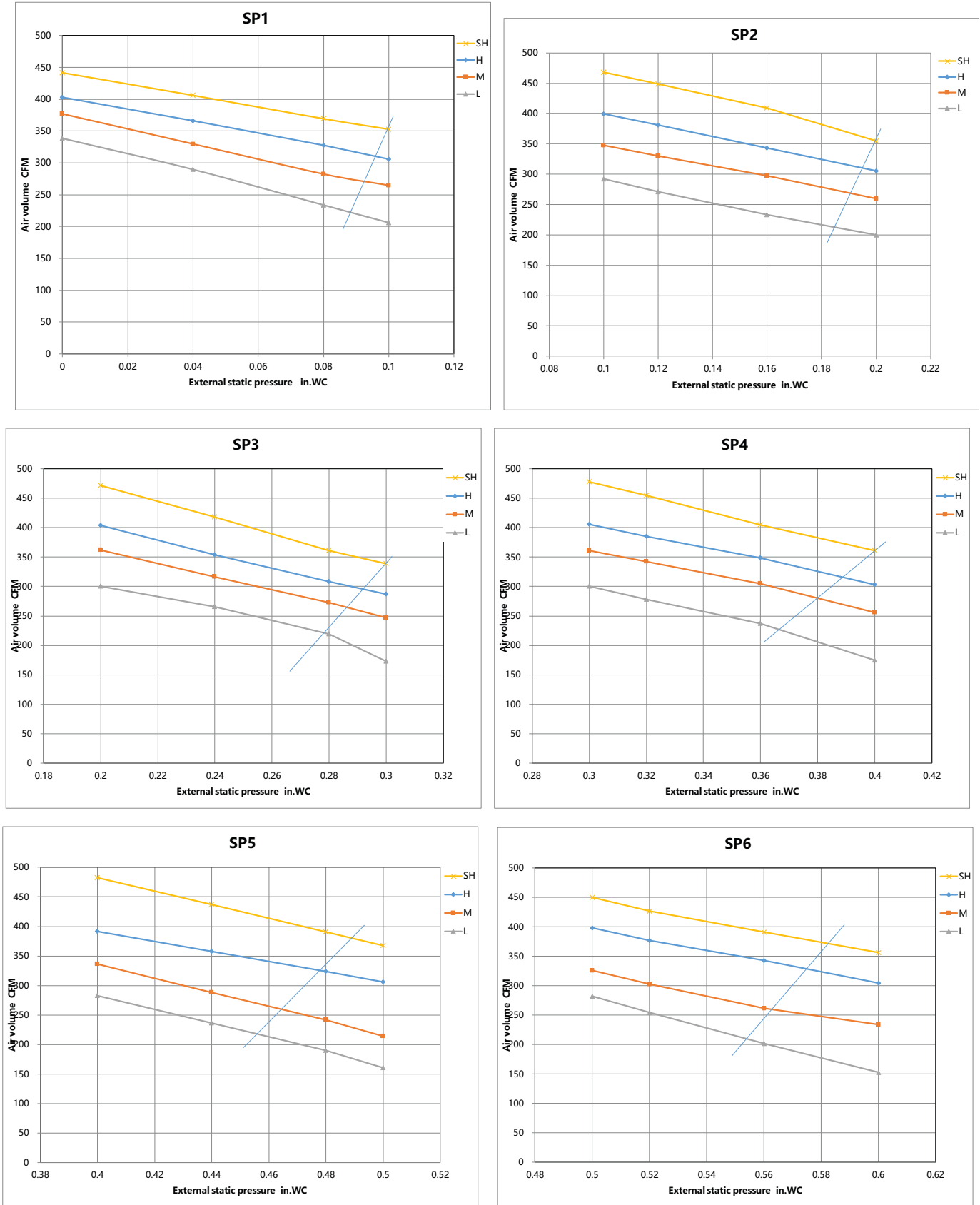
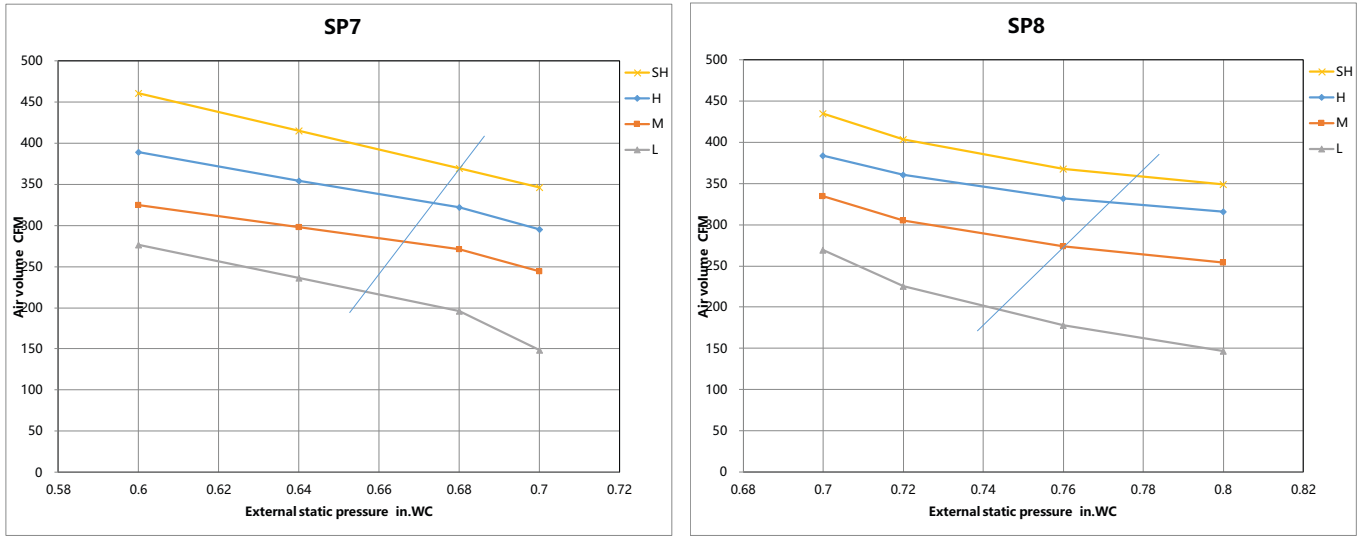

Fig. 22 – High Static Pressure Curves - 9k



Constant air volume

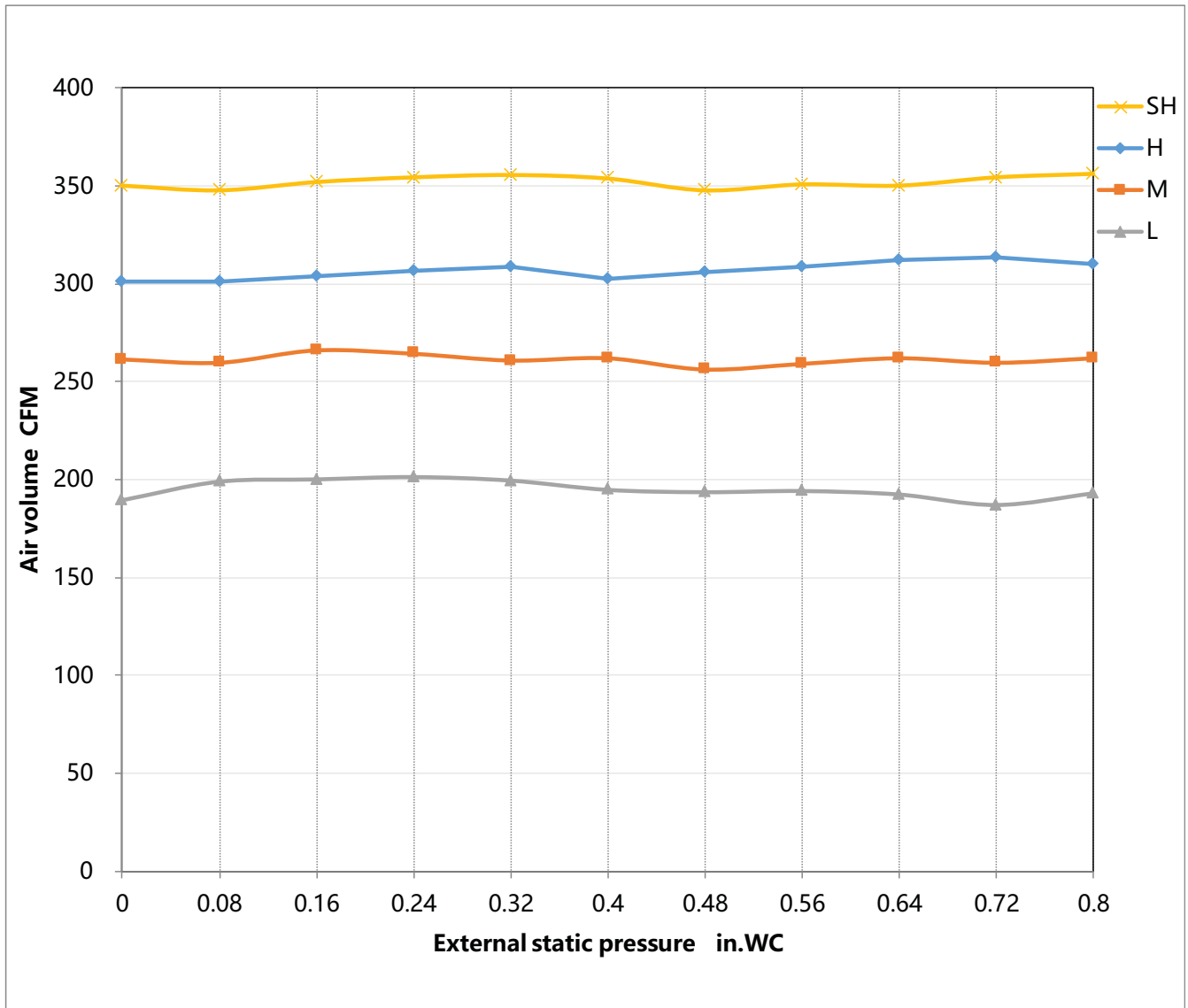

Fig. 23 – High Static Pressure Curves - 9k, Constant Air Volume

12k

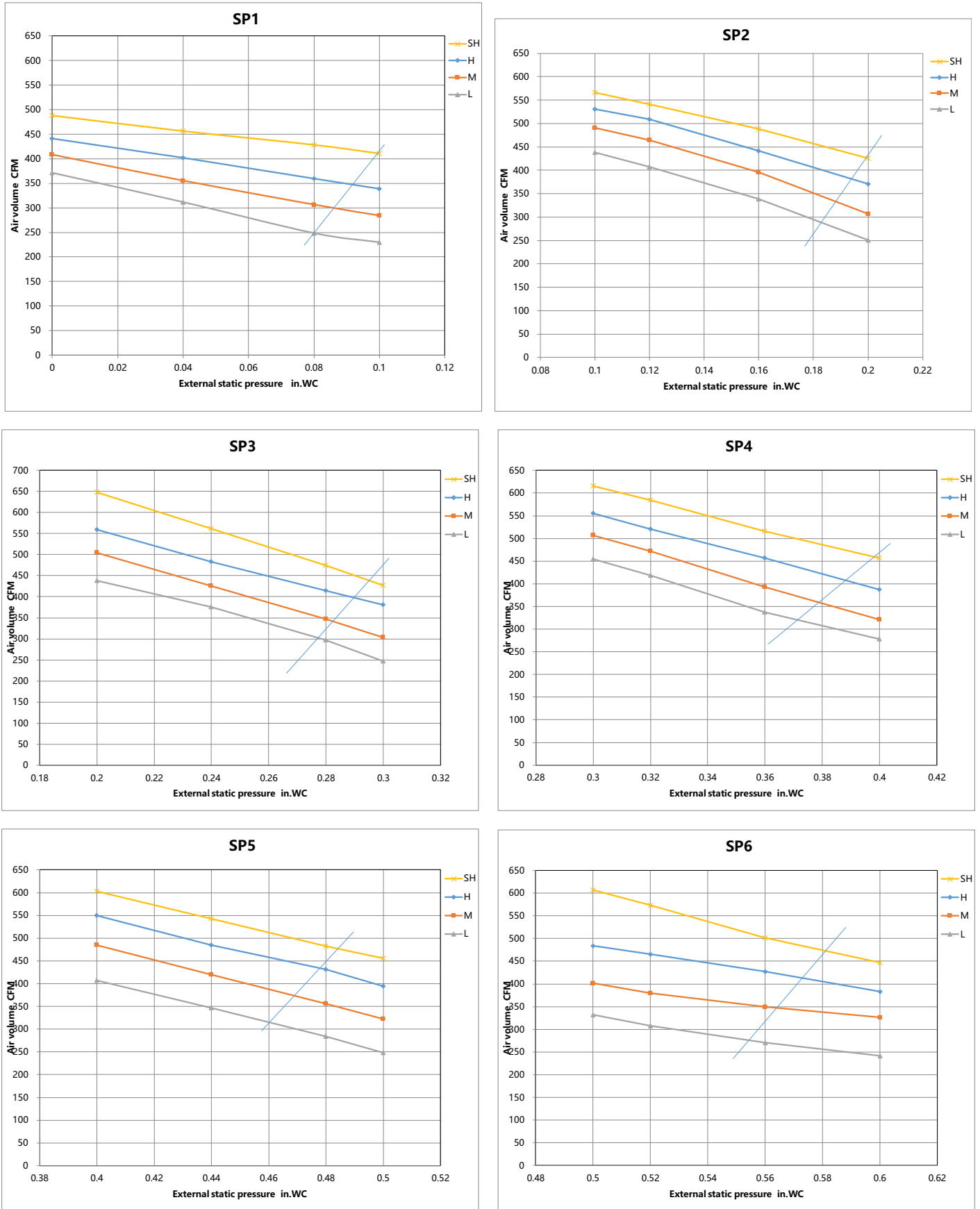
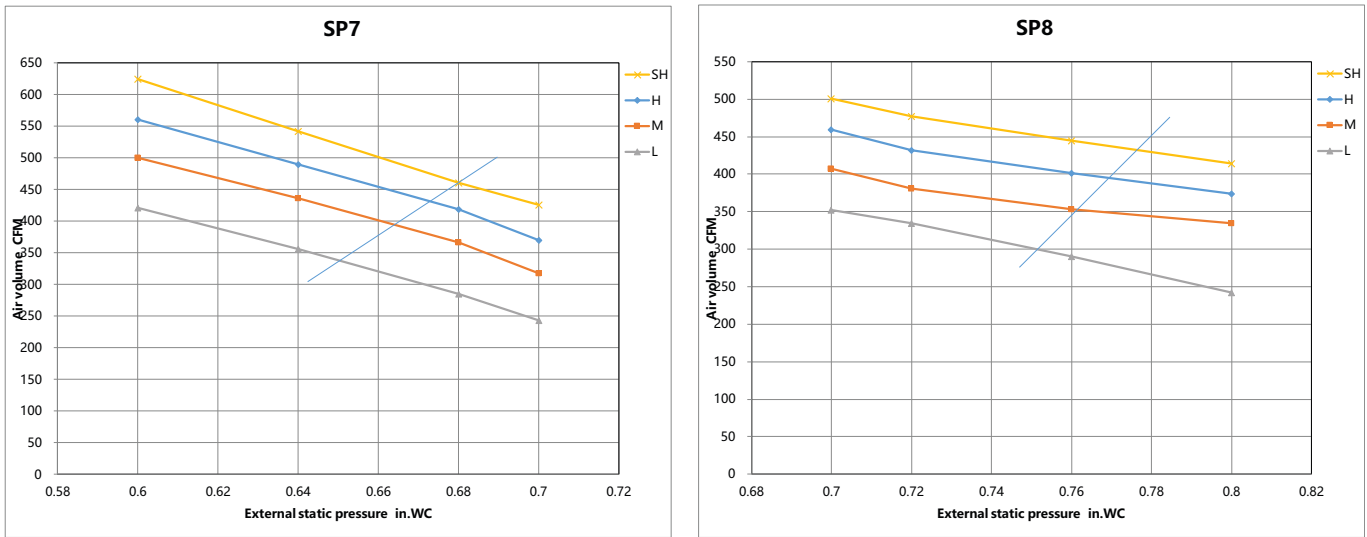

Fig. 24 – High Static Pressure Curves - 12k



Constant air volume

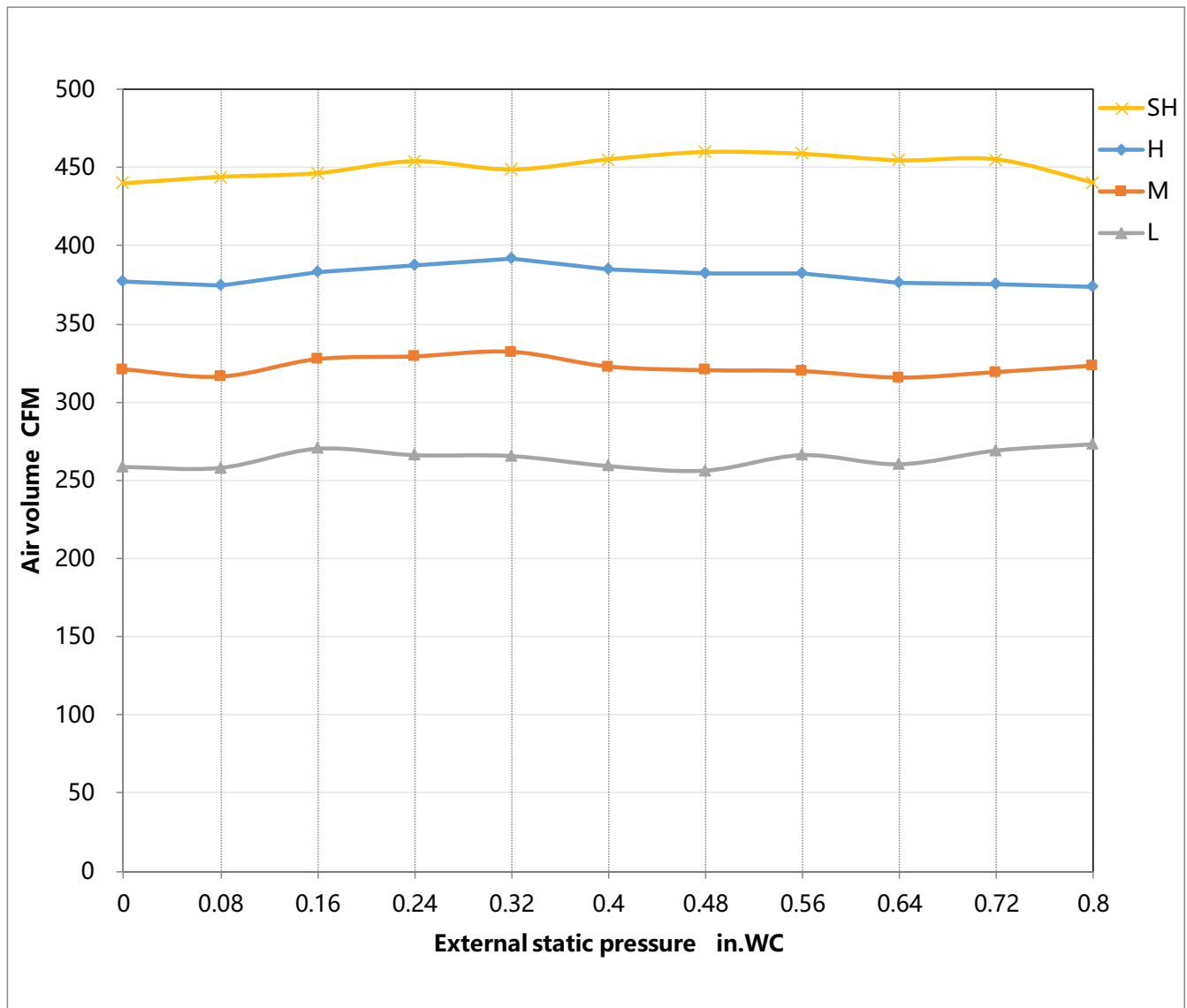

Fig. 25 – High Static Pressure Curves - 12k, Constant Air Volume

18k

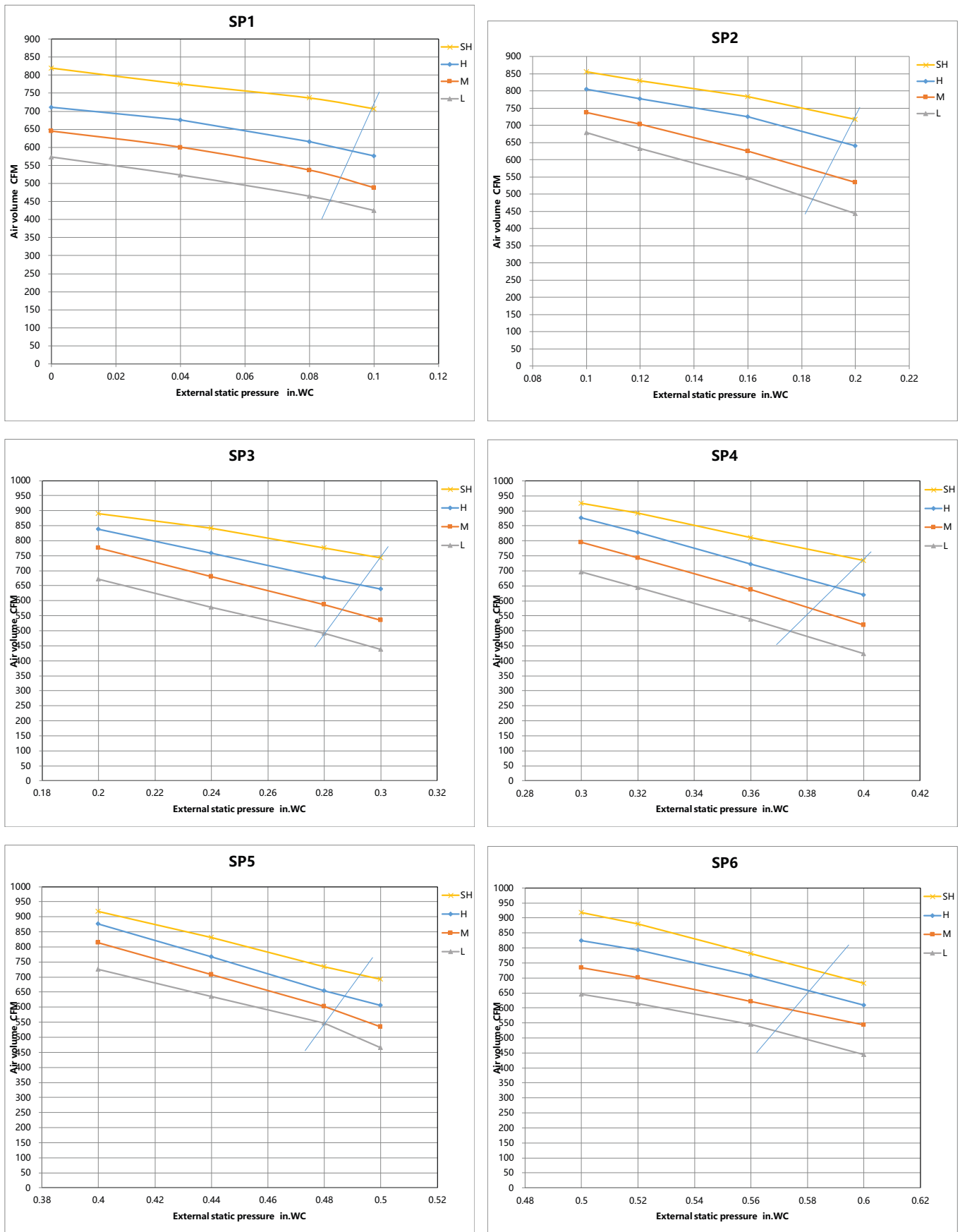
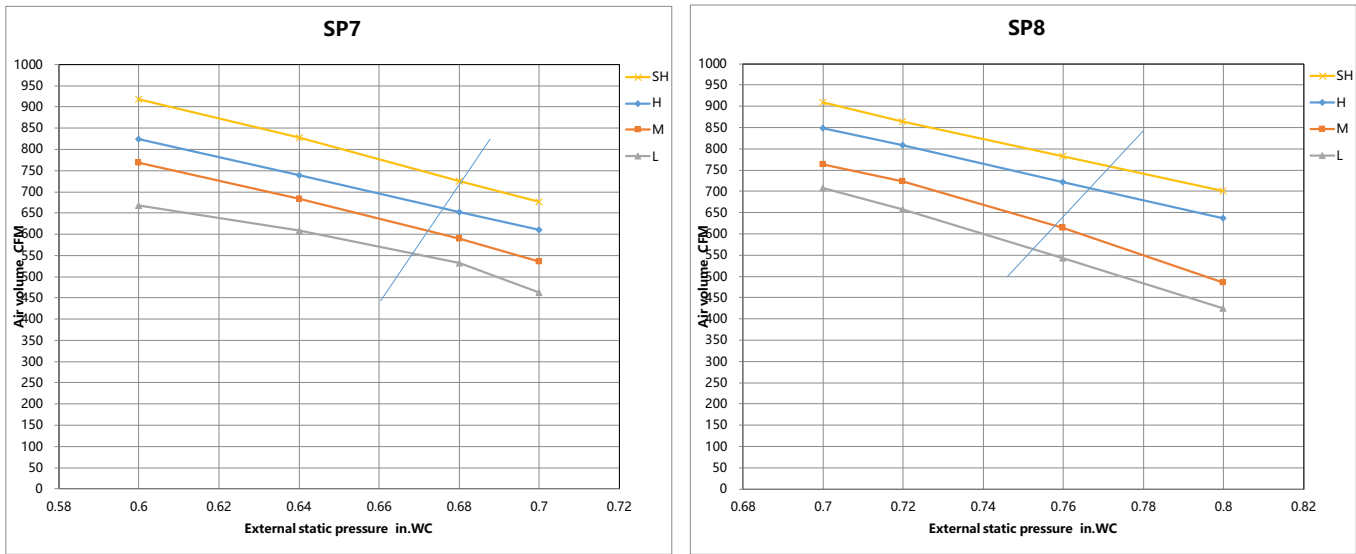

Fig. 26 – High Static Pressure Curves - 18k



Constant air volume

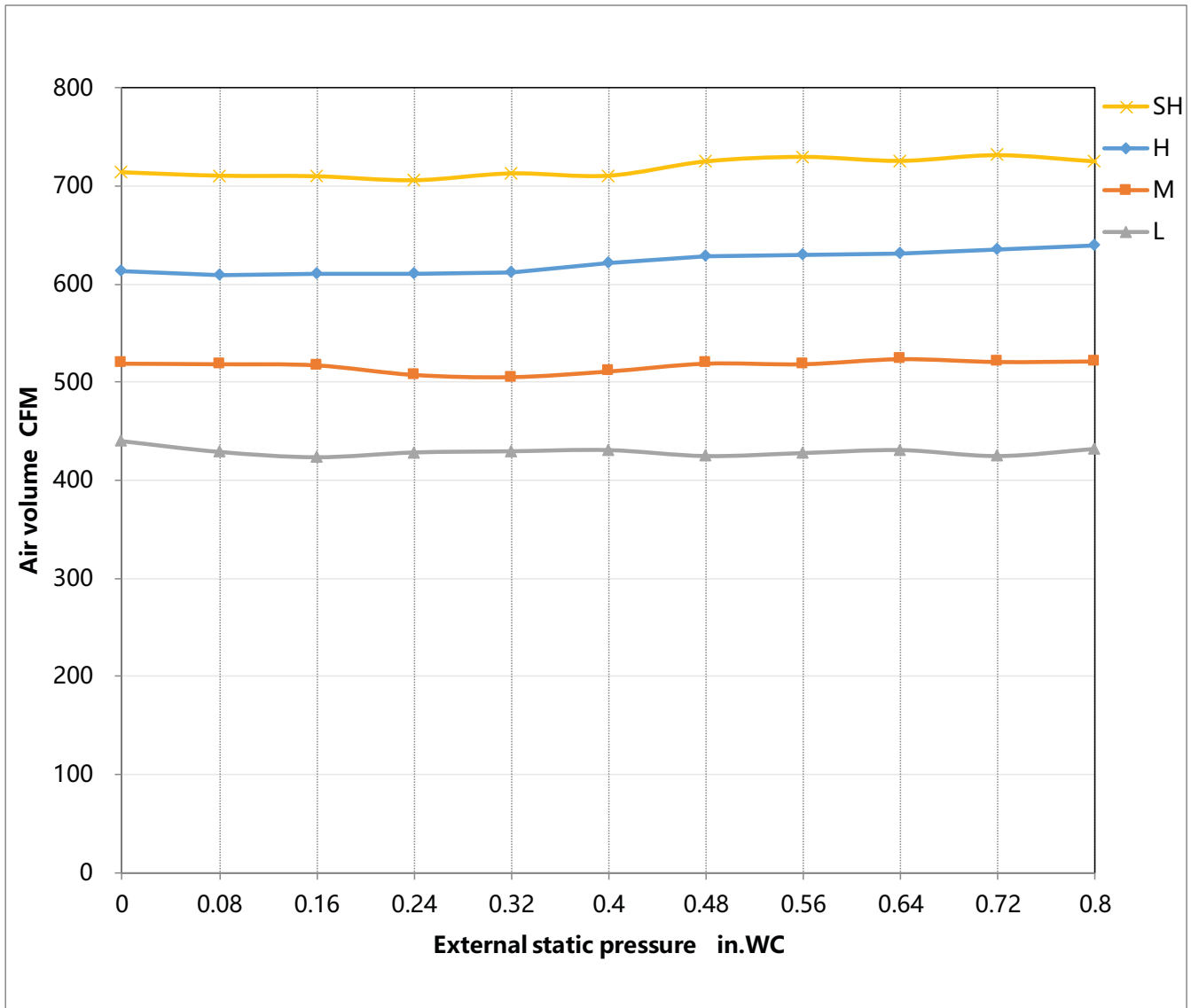

Fig. 27 – High Static Pressure Curves - 18k, Constant Air Volume

24k

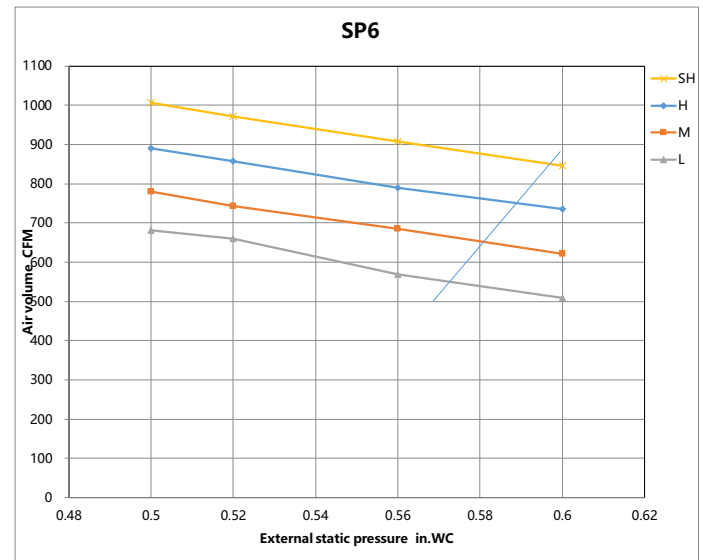
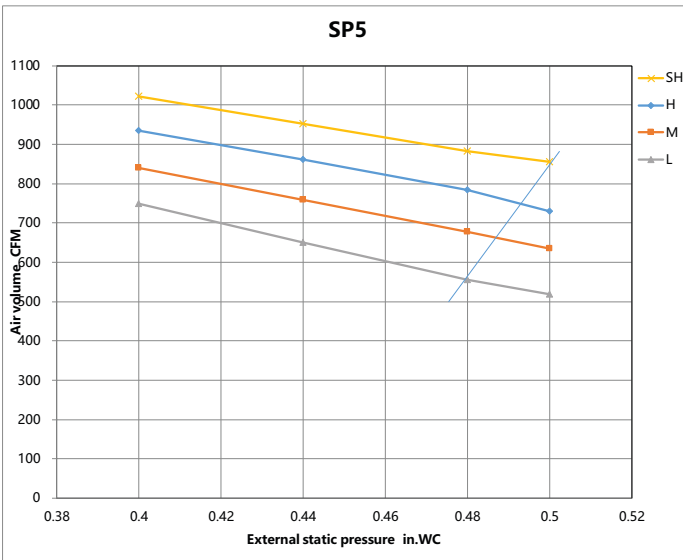
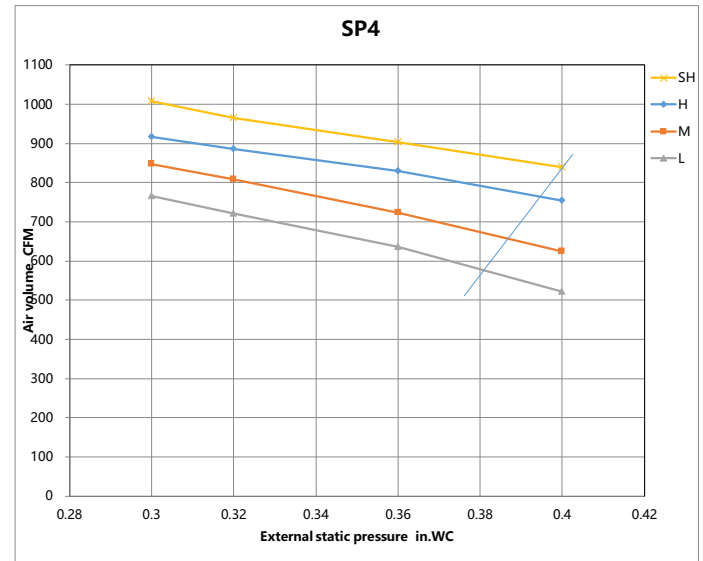
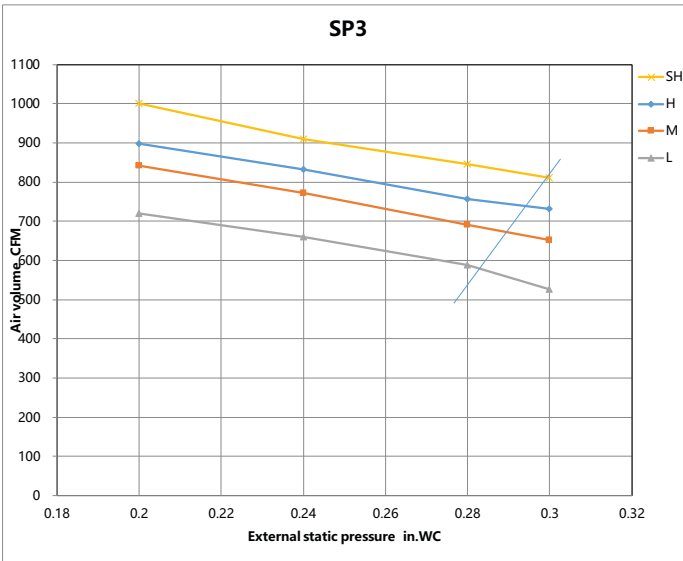
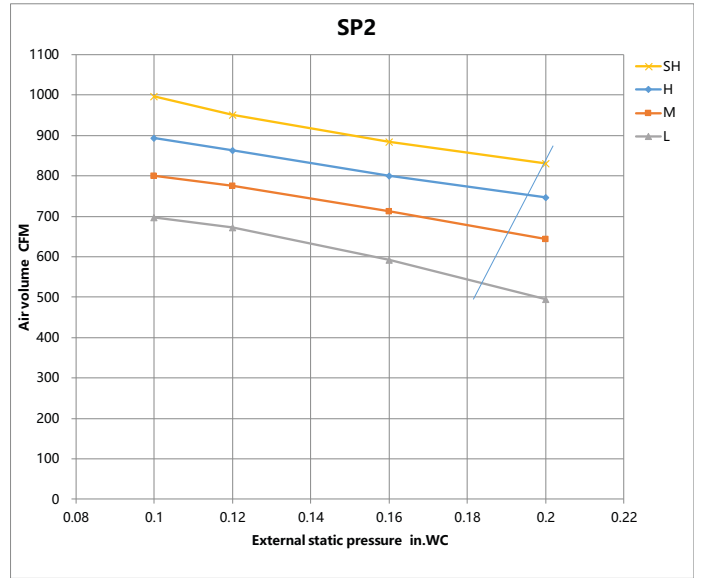
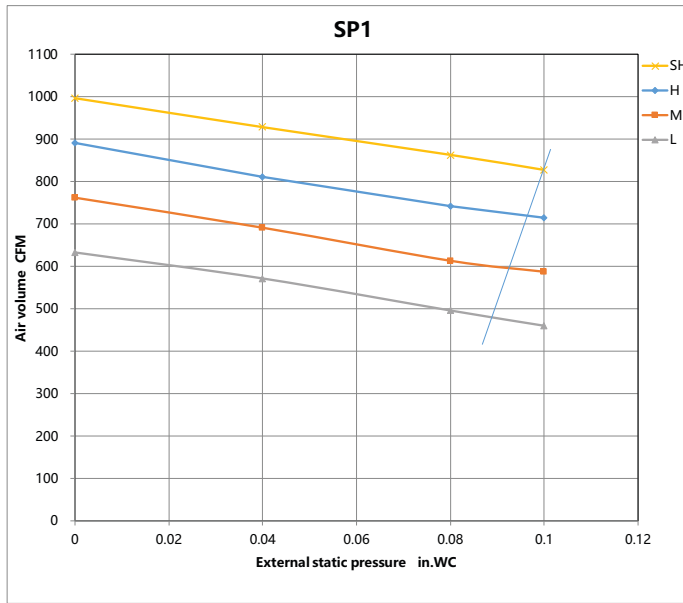
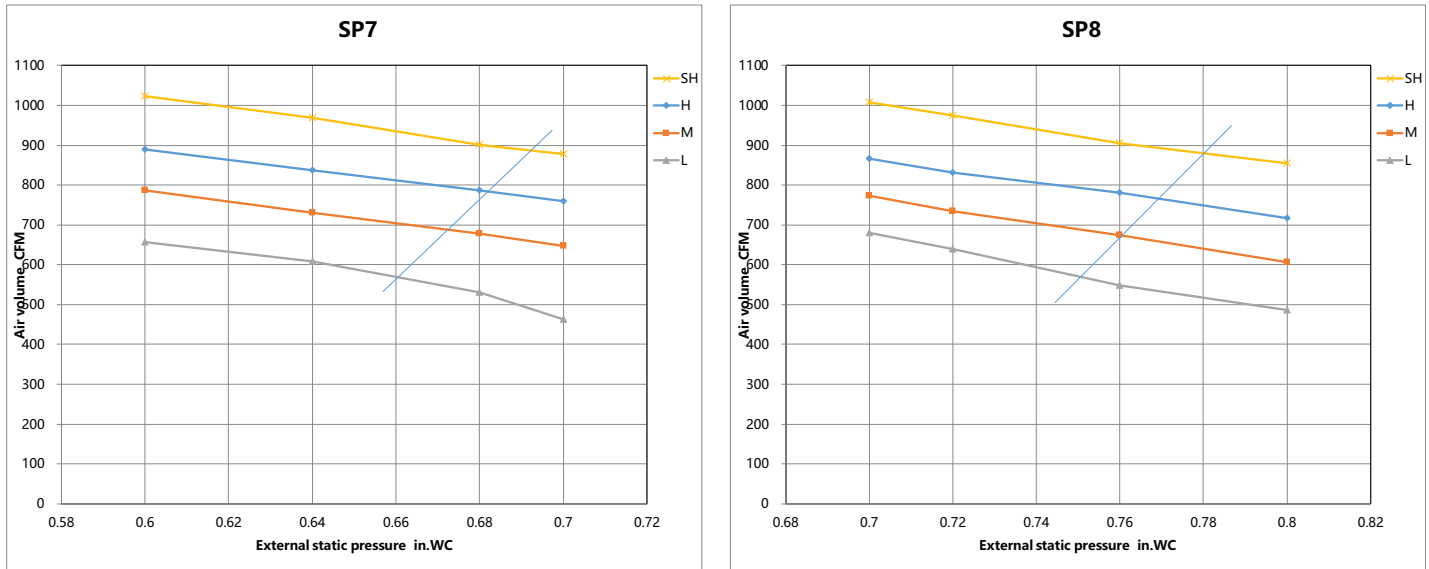

Fig. 28 – High Static Pressure Curves - 24k



Constant air volume

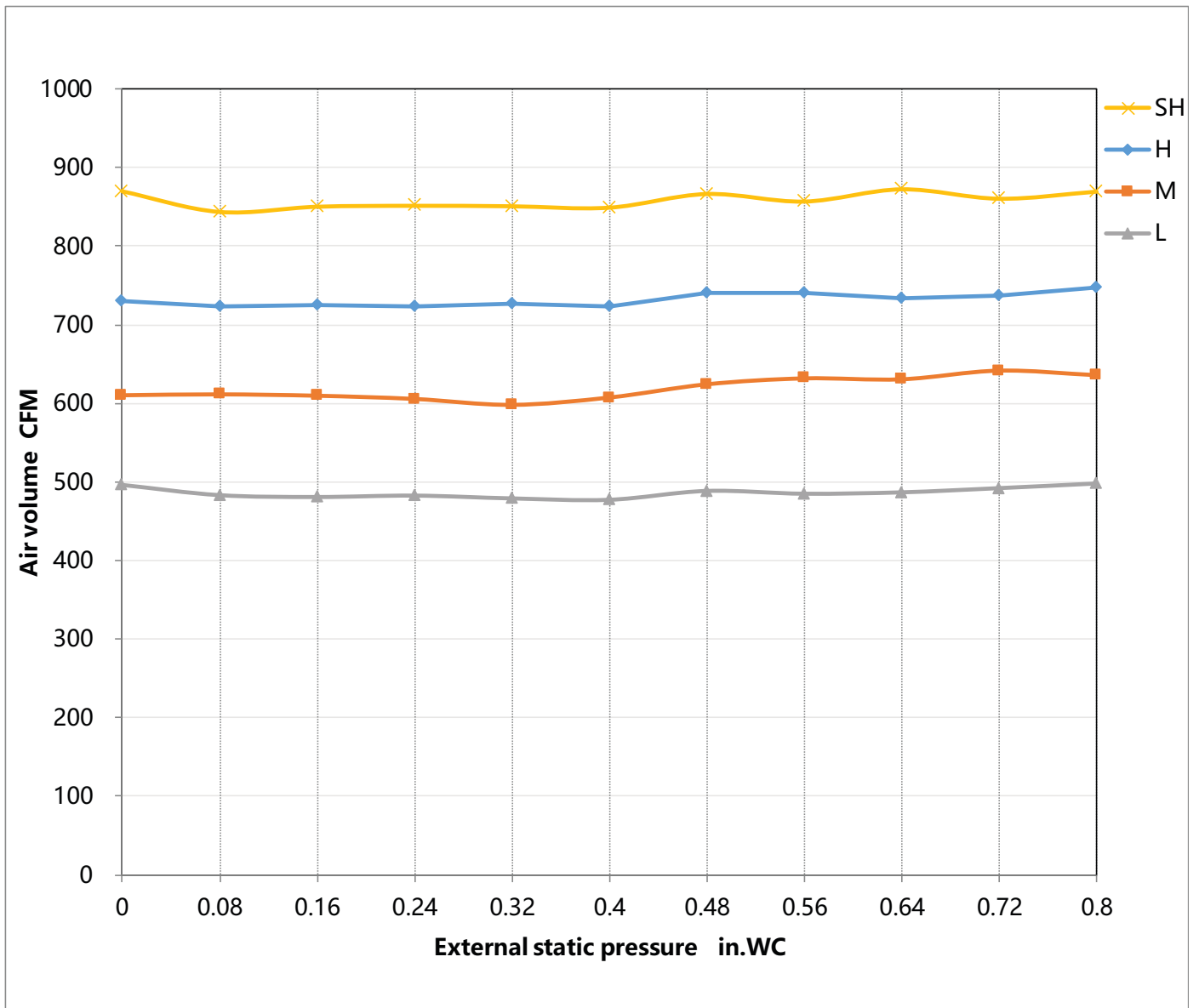

Fig. 29 – High Static Pressure Curves - 24k, Constant Air Volume

36k

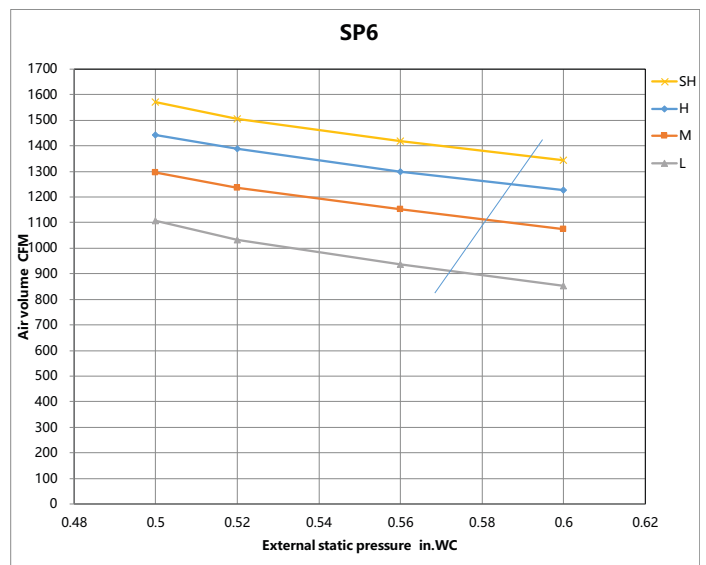
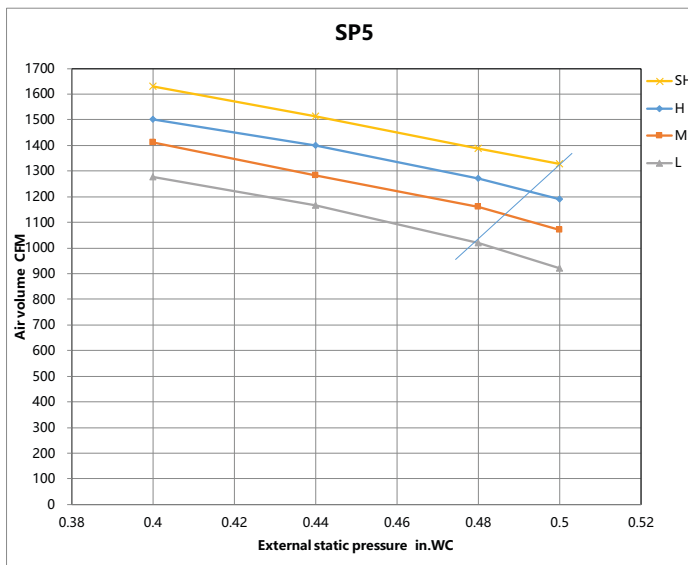
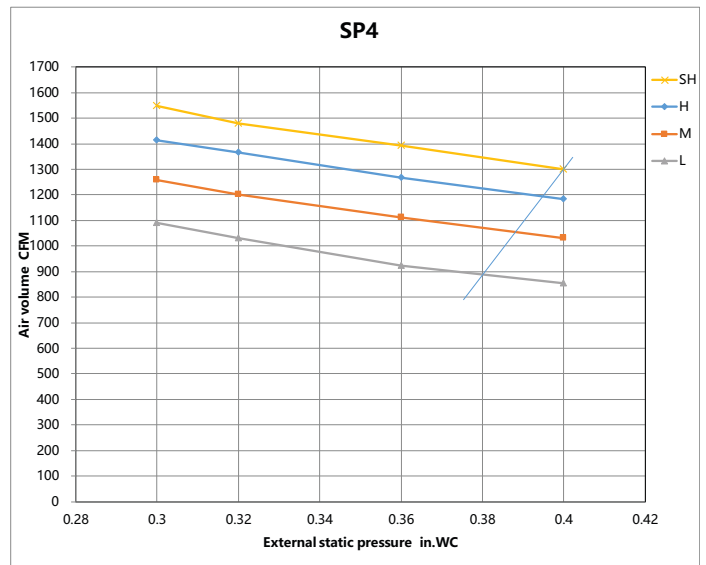
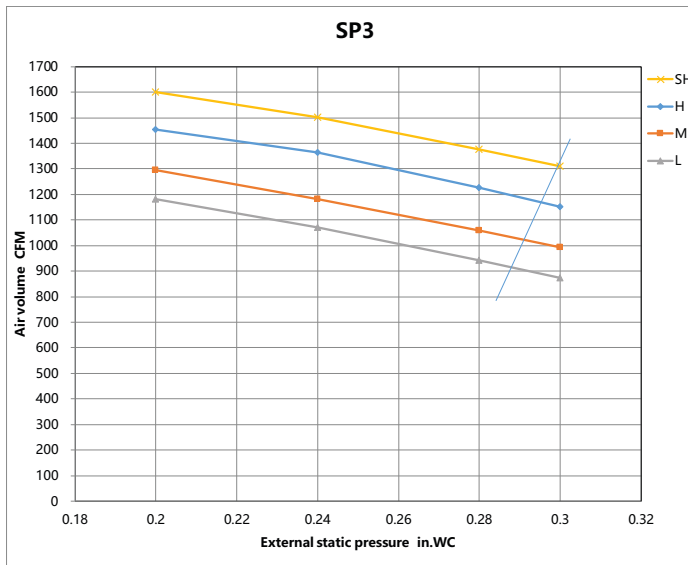
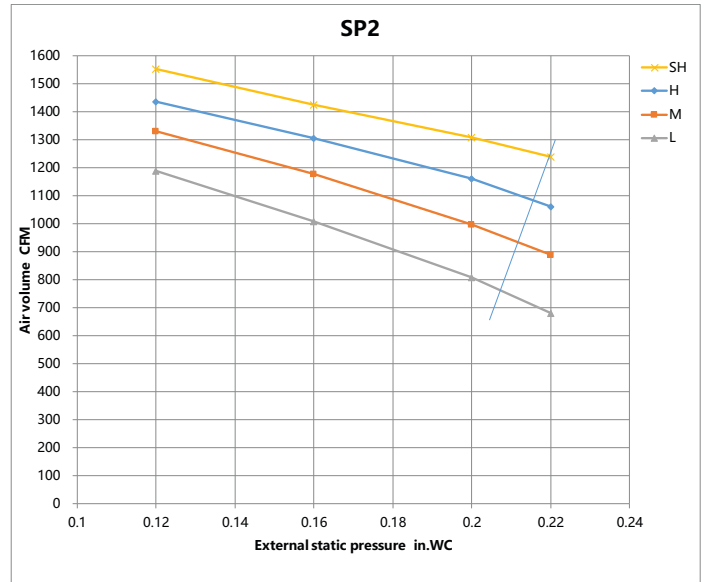
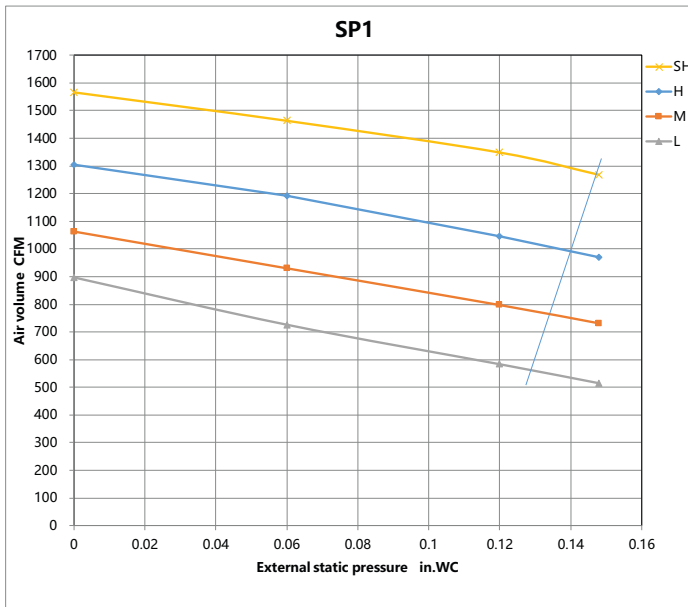
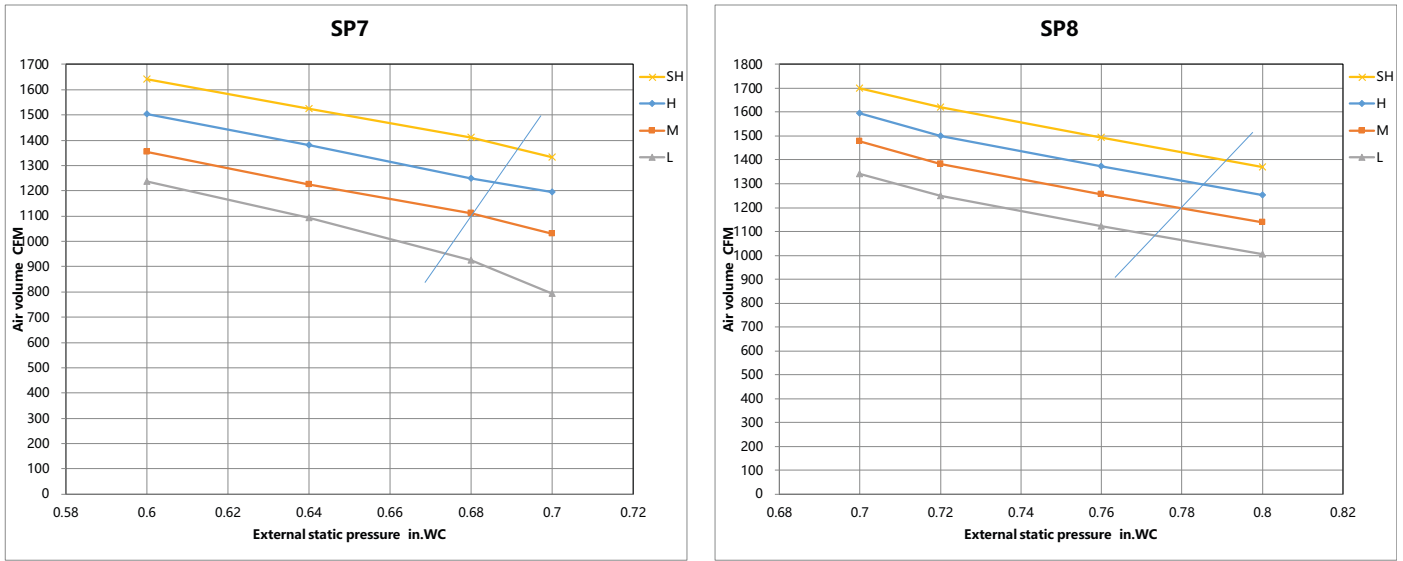

Fig. 30 – High Static Pressure Curves - 36k



Constant air volume

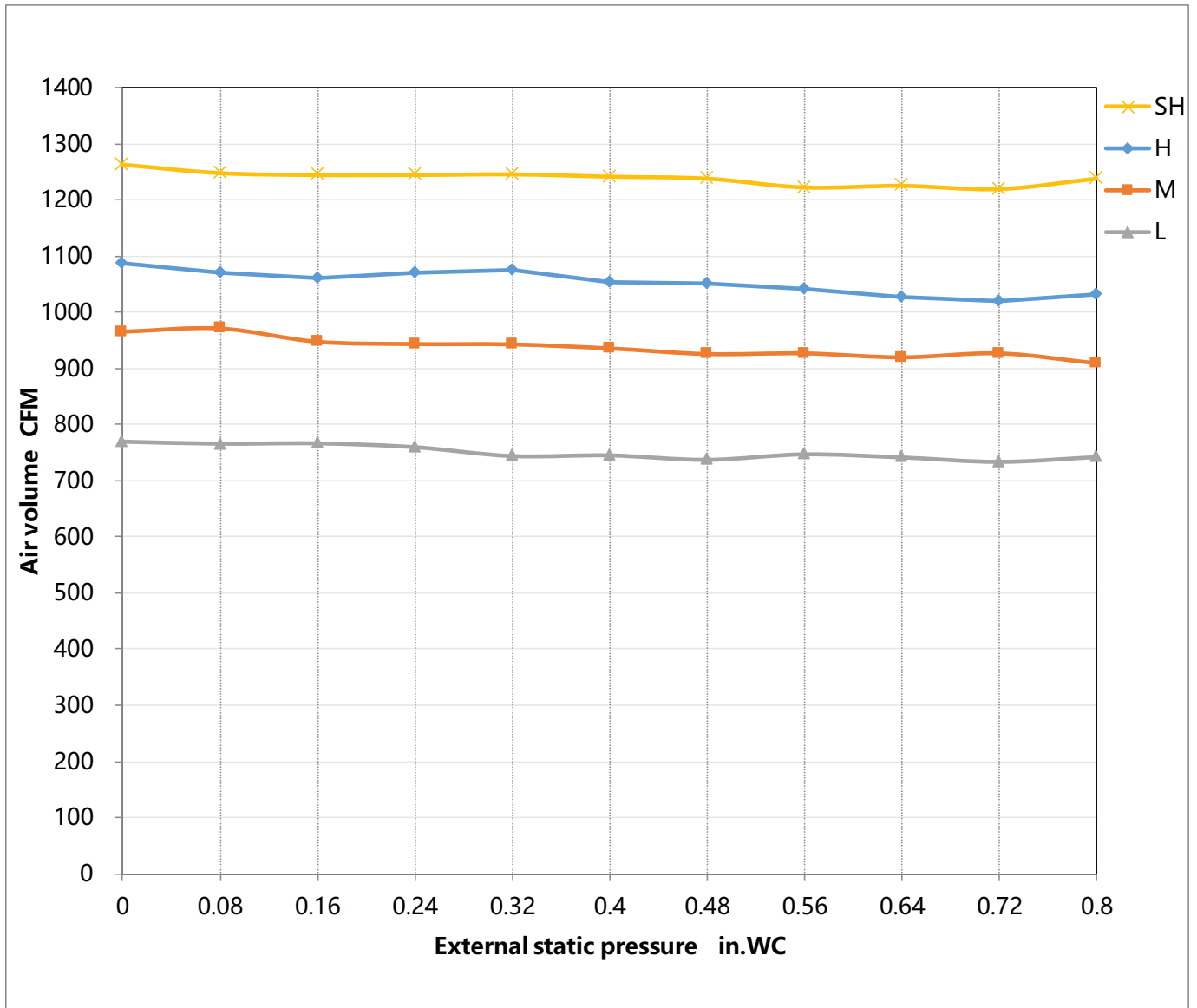

Fig. 31 – High Static Pressure Curves - 36k, Constant Air Volume

48k

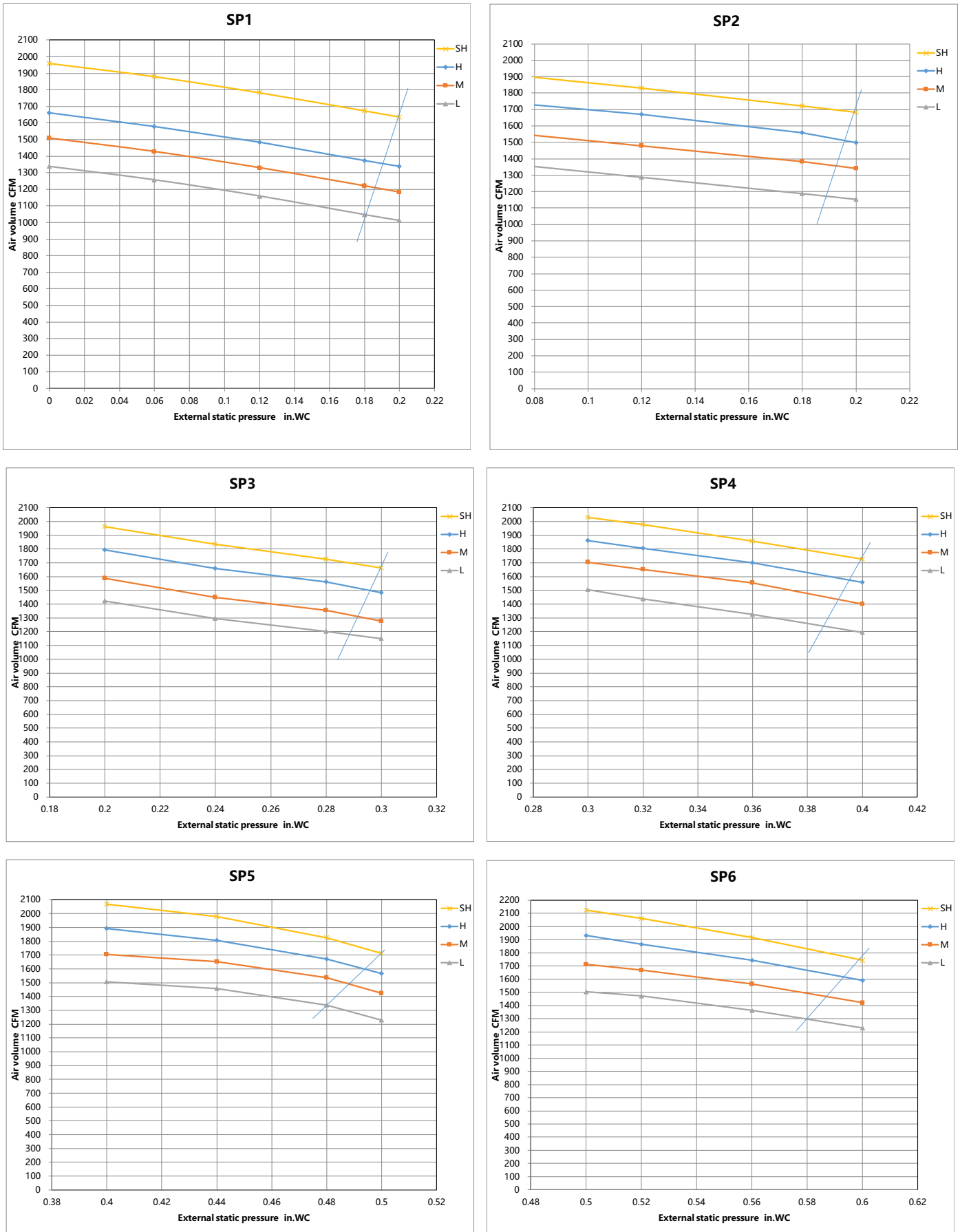
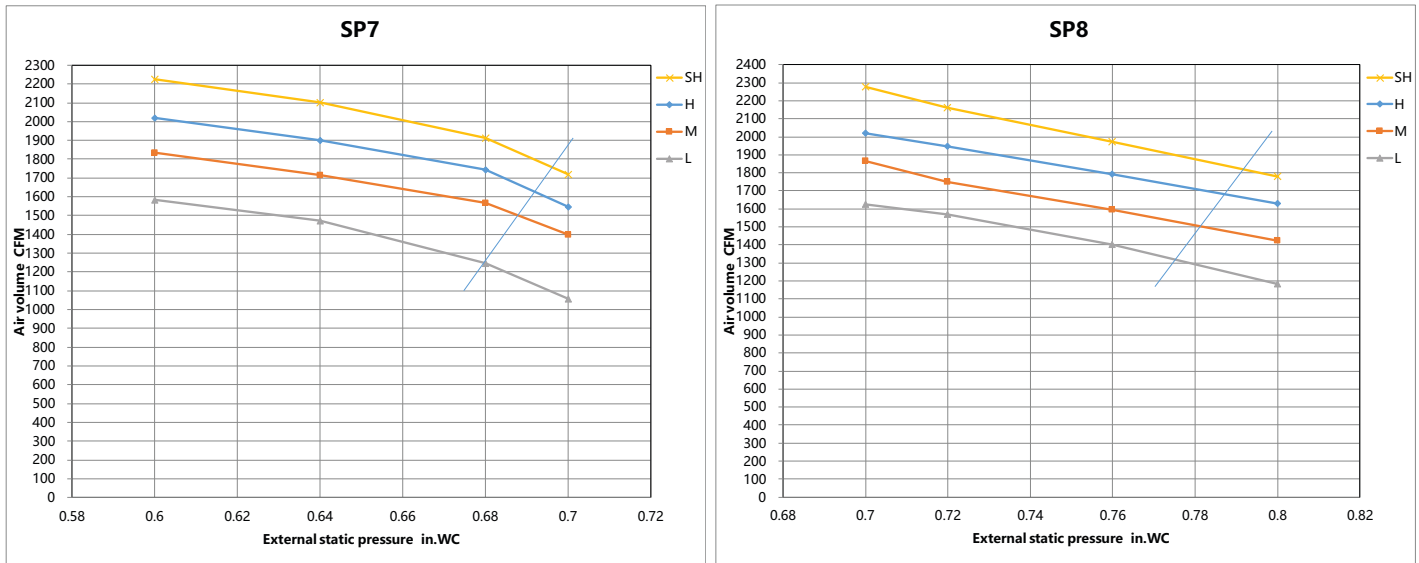

Fig. 32 – High Static Pressure Curves - 48K



Constant air volume

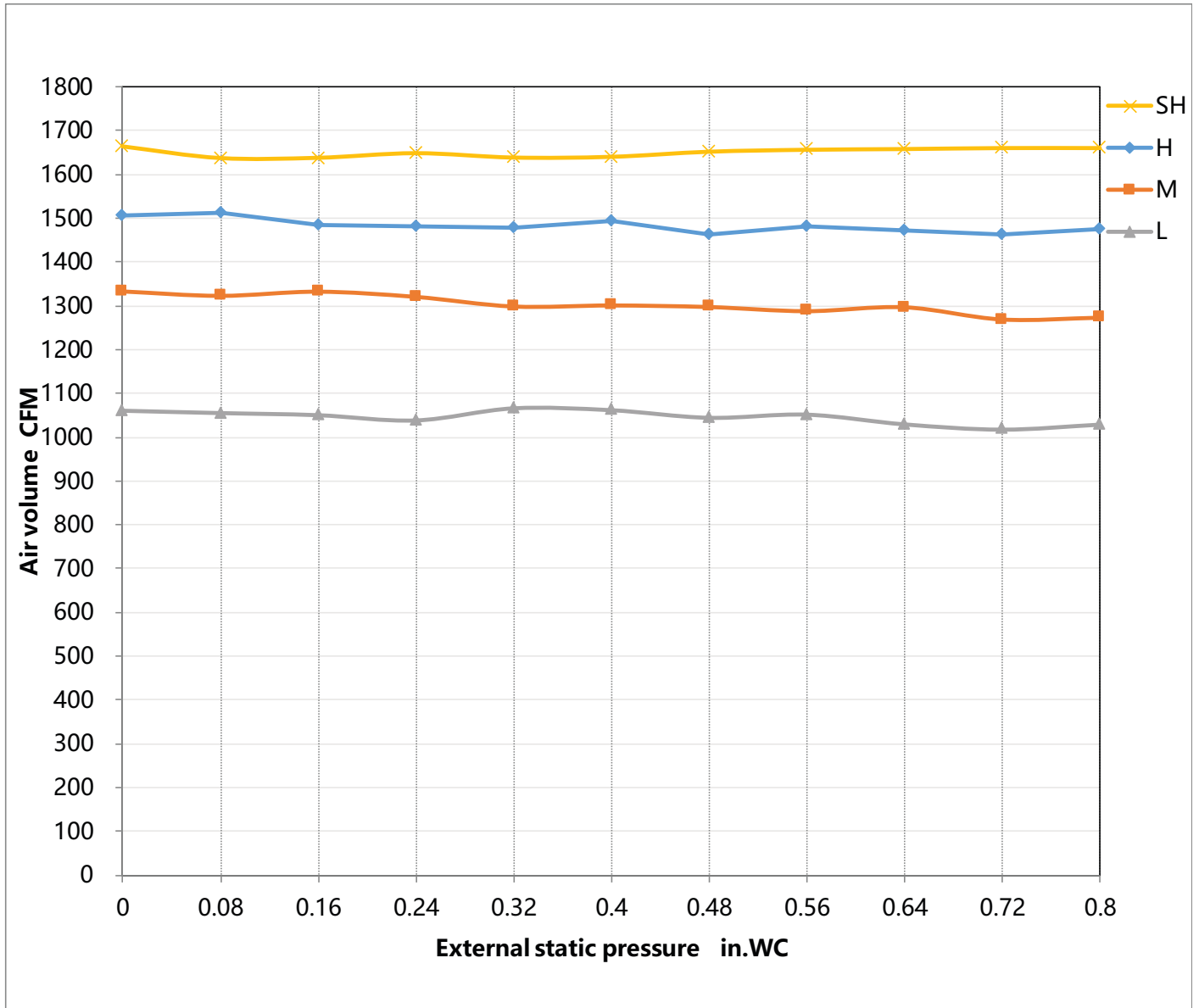

Fig. 33 – High Static Pressure Curves - 48k, Constant Air Volume

58k

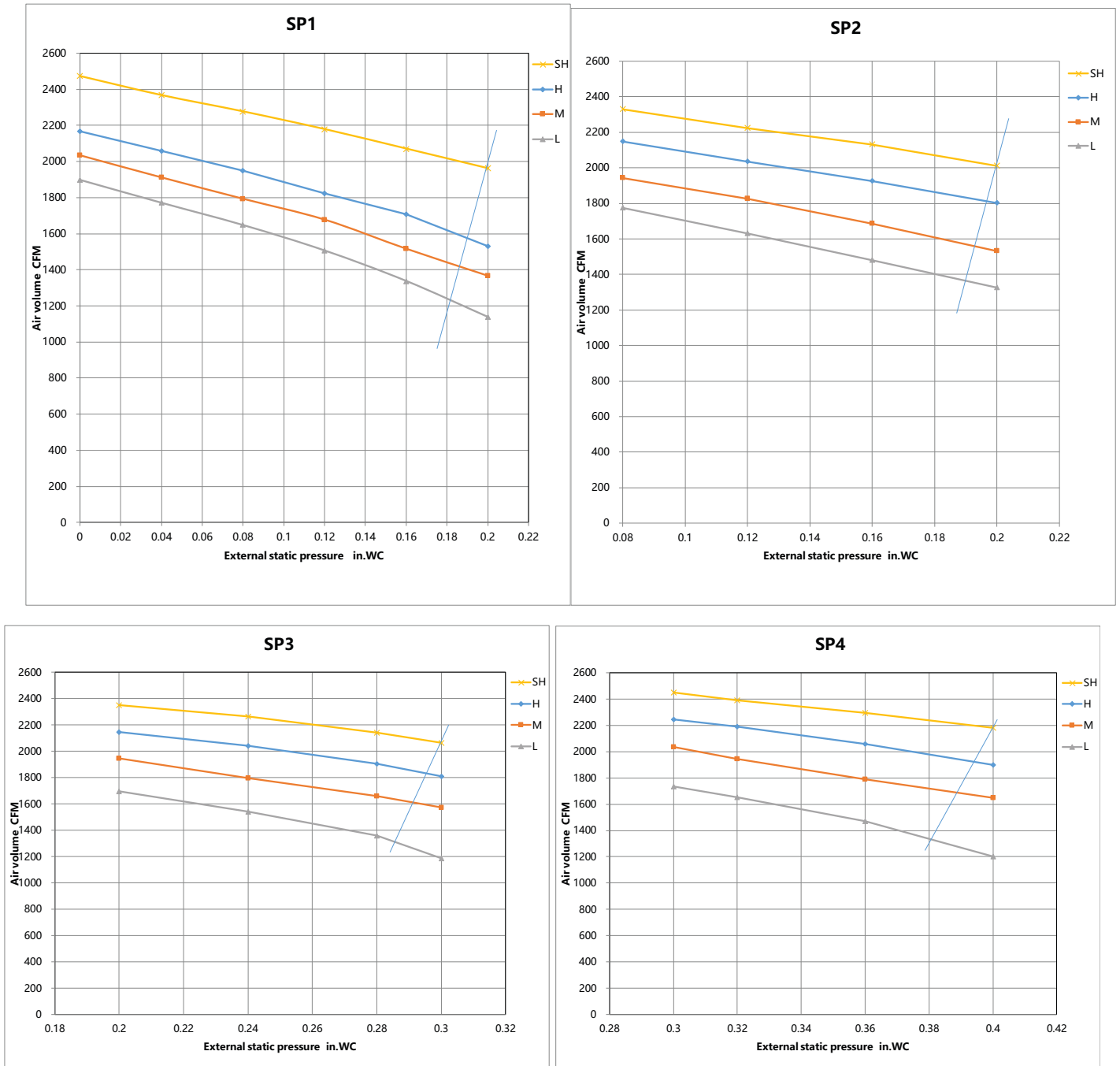

Fig. 34 – High Static Pressure Curves - 58k

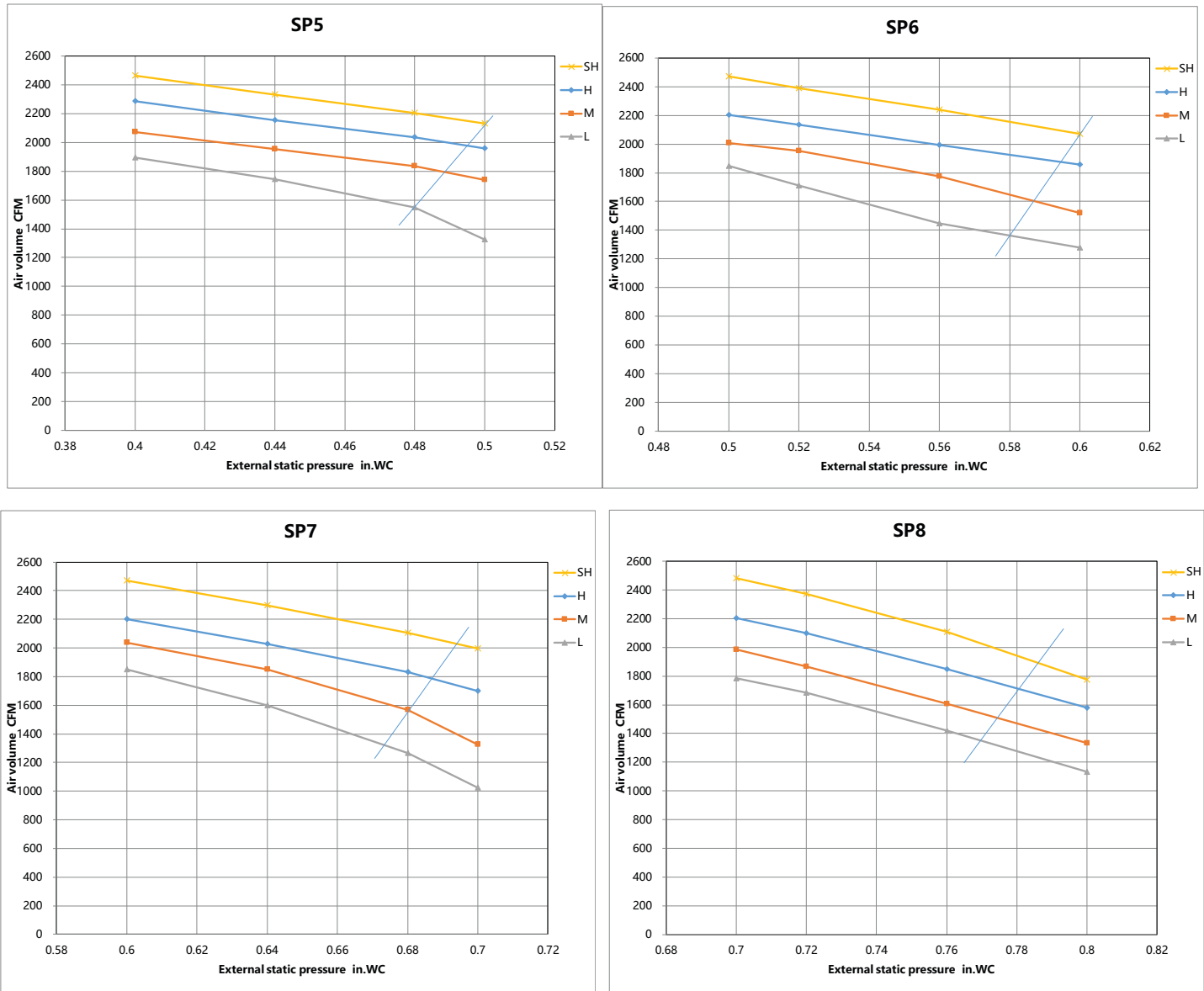

Fig. 35 – High Static Pressure Curves - 58k

Constant air volume

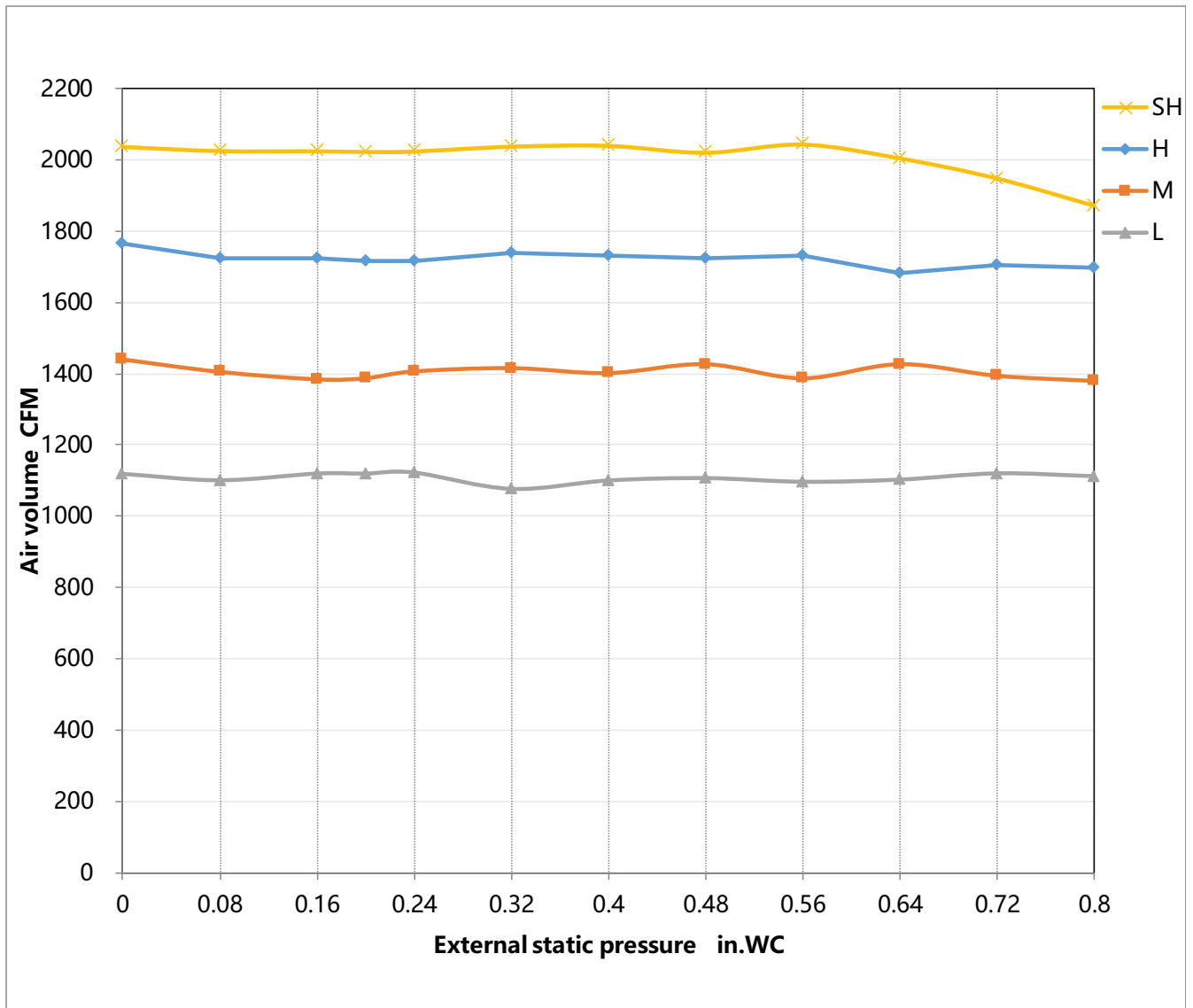

Fig. 36 – High Static Pressure Curves - 58k, Constant Air Volume

MOISTURE REMOVAL

Moisture Removal	Liter/Hour	1.45	2	2.36	4.3	6.13
	Gal/Day	9.2	12.7	15	27.3	38.9

PIPING SPECIFICATIONS

NAME	MODEL	LIQUID SIDE	GAS SIDE	REMARKS
Connecting Pipe Assembly	6K, 9K, 12K	Ø1/4in (Ø6.35mm)	Ø3/8in (Ø9.52mm)	Pipes are not included in the accessories so you will need to purchase them from the local dealer.
	18K	Ø1/4in (Ø6.35mm)	Ø1/2in (Ø12.7mm)	
	24K	Ø3/8in (Ø9.52mm)	Ø5/8in (Ø16mm)	
	36K, 48K, 58K	Ø3/8in (Ø9.52mm)	Ø3/4in (Ø19mm)	

REFRIGERANT SYSTEM DIAGRAM

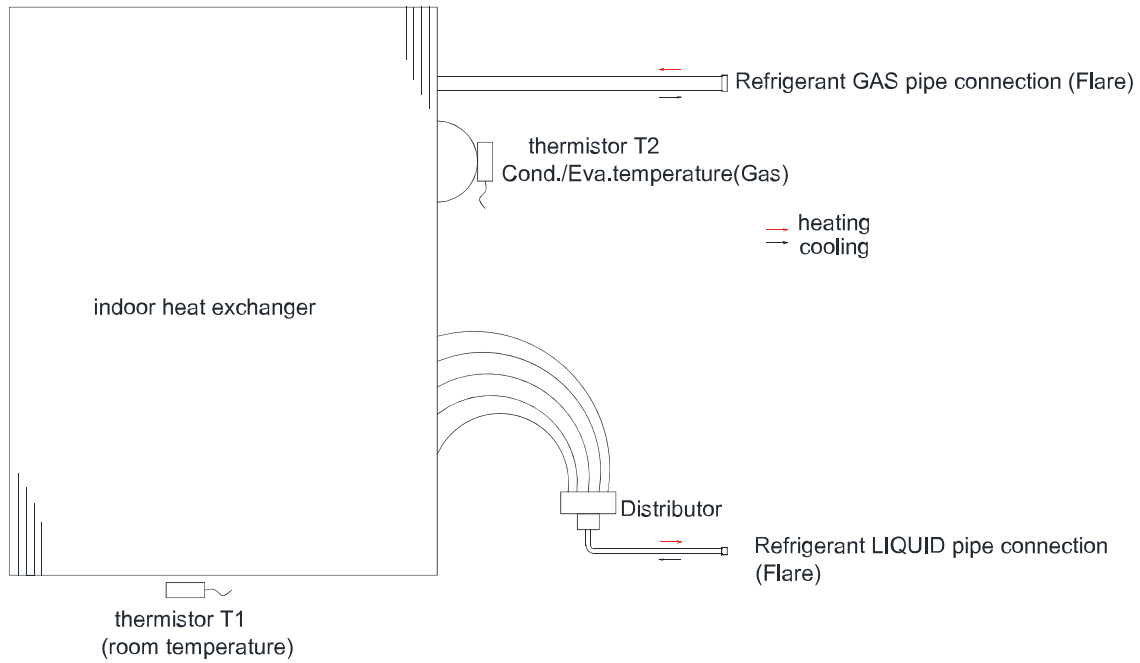

Fig. 37 – Refrigerant System Diagram

WIRING DIAGRAMS

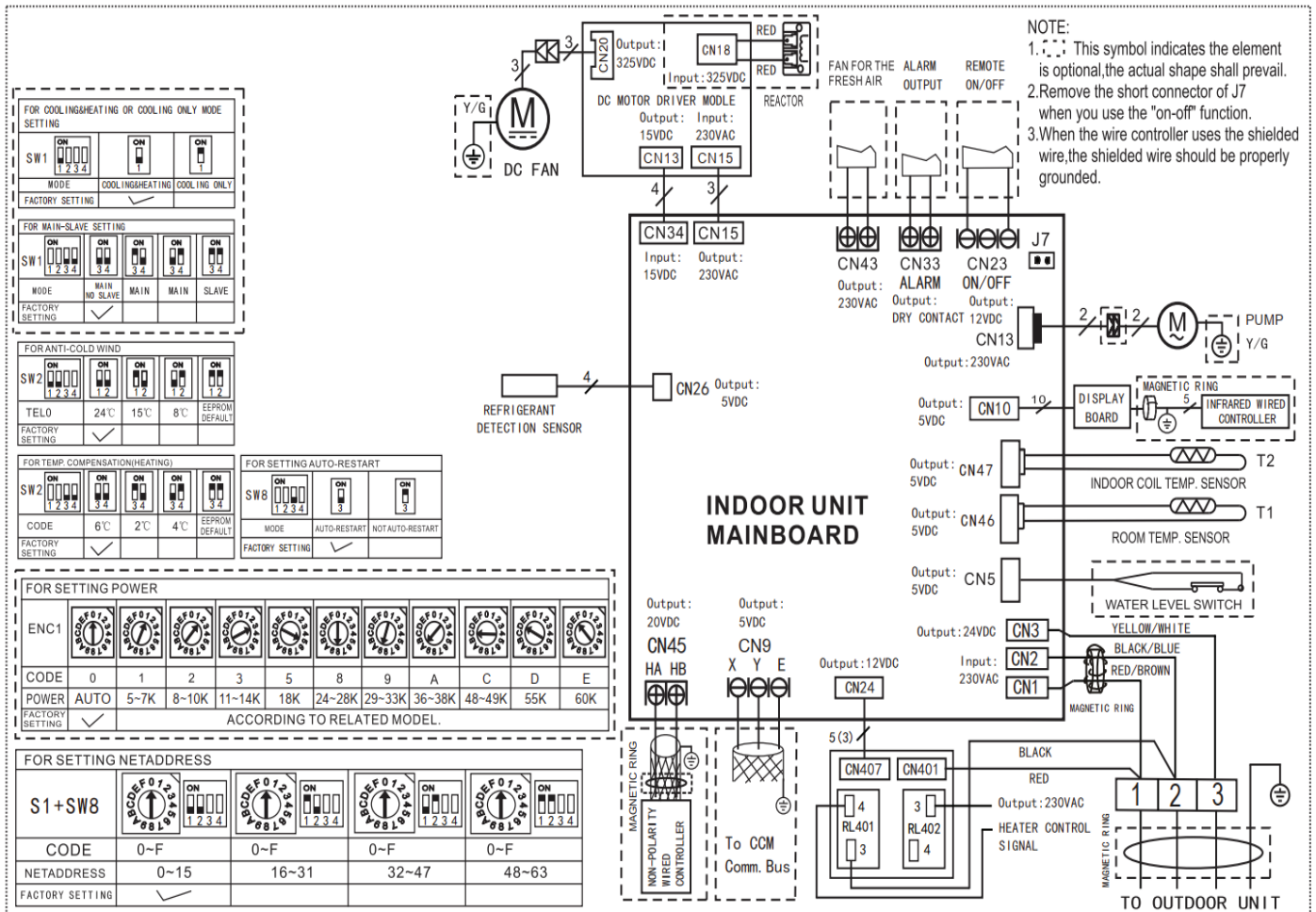

Fig. 38 – Size 06K

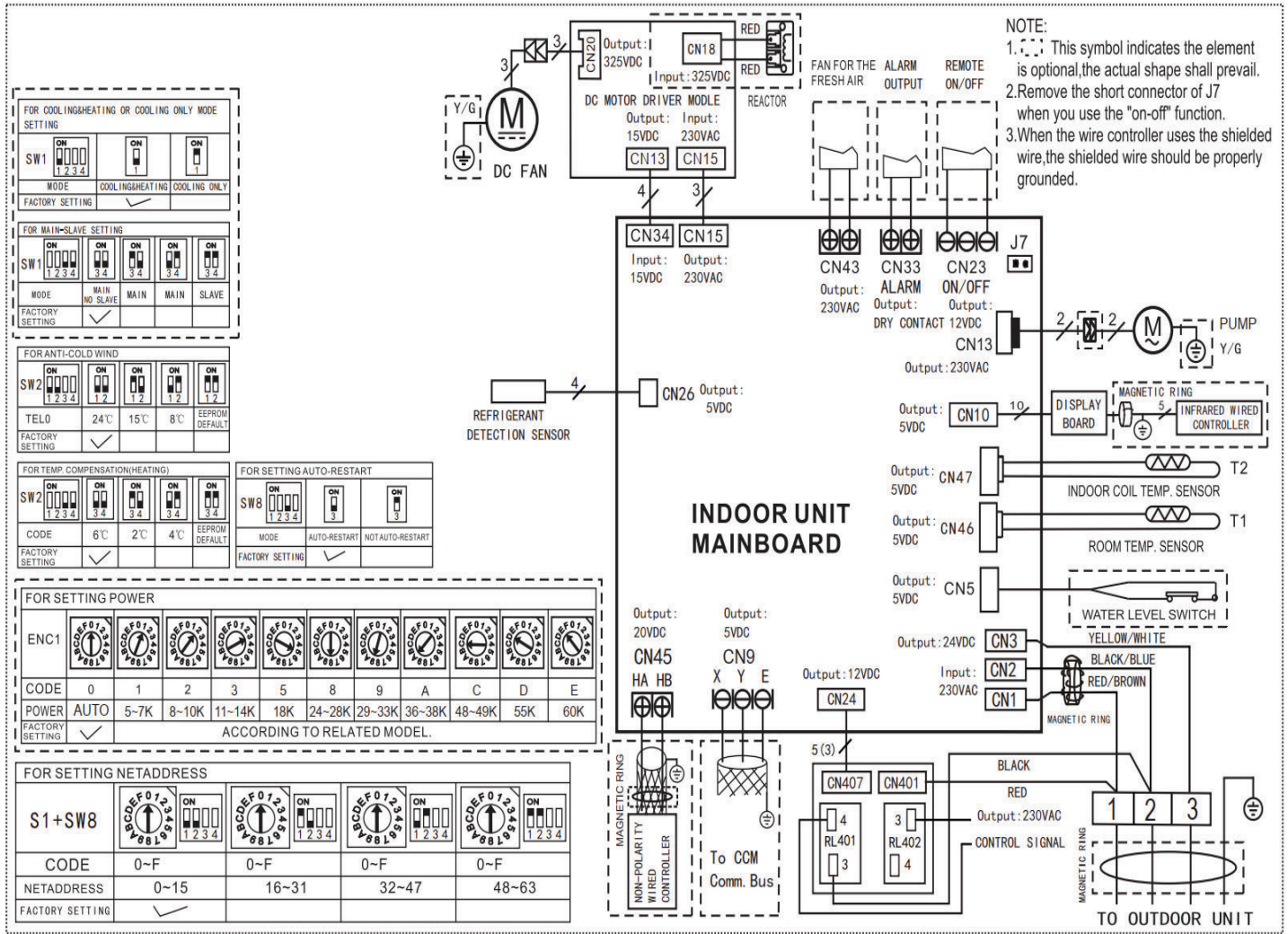

Fig. 39 – Size 09/12/18/24K

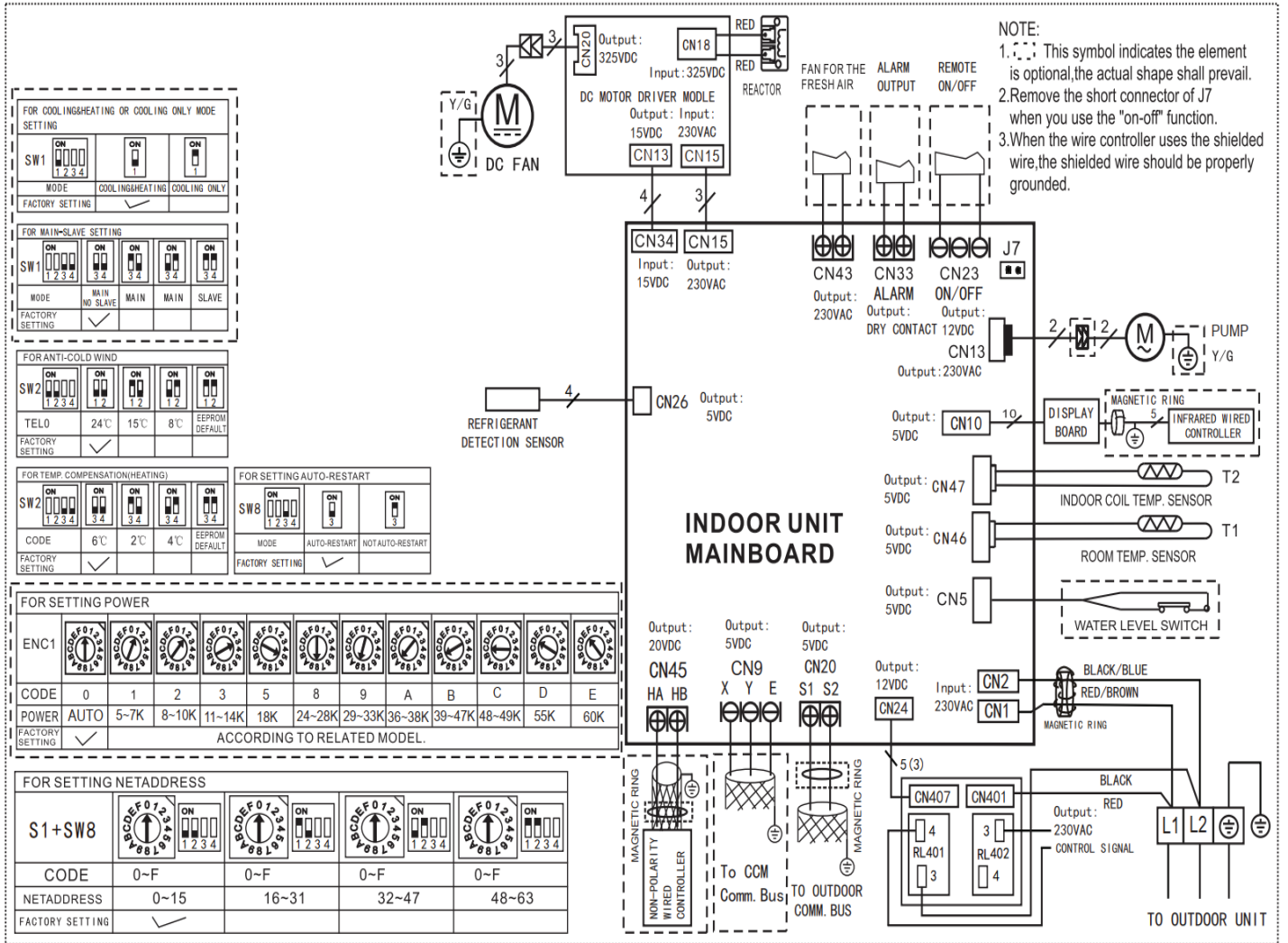

Fig. 40 – Sizes 36/48/58K

GUIDE SPECIFICATIONS

SLIM DUCTLESS SYSTEM

Size Range: 1/2 to 5 Ton Nominal Cooling and Heating Capacity
Model Number: **45MBDA**

Part 1 - GENERAL

1.01 System Description

Indoor, in-ceiling cassette, direct-expansion fan coils are matched with a heat pump outdoor unit.

1.02 Agency Listings

Unit are rated per AHRI Standards 210/240 and listed in the AHRI directory as a matched system.

1.03 Delivery, Storage, And Handling

Units are stored and handled per manufacturer's recommendations.

1.04 Warranty (For Inclusion By Specifying Engineer)

Part 2 - PRODUCTS

2.01 Equipment

A. General:

Indoor, direct-expansion fan coil. Unit is complete with a cooling/heating coil, fan, fan motor, piping connectors, electrical controls, microprocessor control system, and an integral temperature sensing.

B. Unit Cabinet:

Unit cabinet is constructed of galvanized steel. The cabinet is fully insulated for improved thermal and acoustic performance.

C. Fans:

The fan is the tangential direct-drive blower type with air intake at the rear or bottom of the unit and discharge at the front.

D. Coil:

The coil is a copper tube with aluminum fins and galvanized steel tube sheets. Fins are bonded to the tubes by mechanical expansion and specially golden hydrophilic pre-coated for enhanced wet-ability. A drip pan under the coil has a factory installed condensate lift pump and a drain connection for a hose attachment to remove condensate.

E. Motors:

Motors are open drip-proof, permanently lubricated ball bearing with inherent overload protection. Fan motors are 3-speed.

F. Controls:

Controls consist of a microprocessor-based control system which controls the space temperature, determines the optimum fan speed, and runs self diagnostics. The temperature control range is 62°F to 86°F (17°C to 30°C) in increments of 1°F or 1°C, and has a 46°F Heating Mode (Heating Setback). The wireless remote controller, has the ability to act as the temperature sensing location for room comfort.

The unit has the following functions (at a minimum):

1. An automatic restart after a power failure at the same operating conditions as at failure.
2. A timer function to provide a minimum 24-hour timer cycle for the system's Auto Start/Stop.
3. Temperature-sensing controls sense the return air temperature.
4. Indoor coil freeze protection.
5. Wireless infrared remote control to enter set points and operating conditions.
6. Dehumidification mode which provides increased latent removal capability by modulating system operation and set point temperature.
7. A fan-only operation to provide room air circulation when no cooling is required.
8. Diagnostics to provide continuous checks of the unit operation and warn of possible malfunctions. Any error messages are displayed at the unit.
9. The fan speed control is user-selectable: high, medium, low, or microprocessor controlled automatic operation during all operating modes.
10. Automatic heating-to-cooling changeover in the heat pump mode. Control includes deadband to prevent rapid mode cycling between heating and cooling.
11. Indoor coil high temperature protection is provided to detect excessive indoor discharge temperature when unit is in the heat pump mode.

G. Filters:

The unit has a filter track with factory-supplied cleanable filters.

H. Electrical Requirements:

The indoor fan motor operates on 208-230V. Power is supplied from the outdoor unit.

I. Operating Characteristics:

The **45MBDA** system has a minimum SEER2 (Seasonal Energy Efficiency Ratio) and HSPF at AHRI conditions, as listed on the specifications table.

J. Refrigerant Lines:

All units should have refrigerant lines that can be oriented to connect from the left, right or back of unit. Both refrigerant lines must be insulated.

K. Refrigerant Leak Detection and Mitigation

System comes with a refrigerant leak sensor and mitigation system.