

45MBDAQ
 Ducted Ductless System
 Sizes 06K-60K

Installation Instructions

TABLE OF CONTENTS



Fig. 1 —Sizes 06K-18K (Low Static)

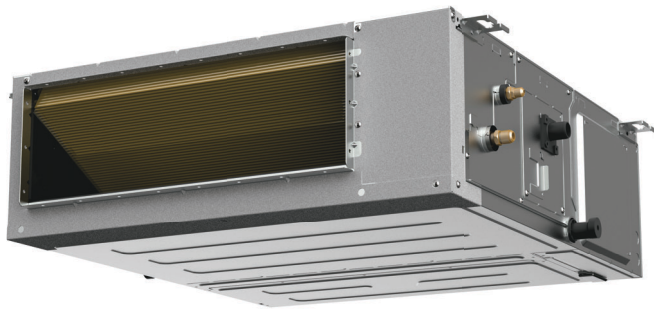

Fig. 2 —Sizes 12K-58K (High Static)

SAFETY CONSIDERATIONS	2
ACCESSORIES	8
DIMENSIONS AND WEIGHTS.....	10
PRODUCT OVERVIEW	11
INSTALLATION SUMMARY	12
A. INSTALL THE INDOOR UNIT	13
DIMENSIONS	14
B. DRAIN CONNECT.....	22
C. CONDENSATE DRAIN INSTALLATION.....	25
D. CONNECT THE REFRIGERANT PIPES	29
WIRELESS REMOTE CONTROLLER INSTALLATION	31
WIRED REMOTE CONTROLLER INSTALLATION.....	32
OPTIONAL WIRED WALL-MOUNTED REMOTE CONTROL IN- STALLATION	32
FAN PERFORMANCES AT VARYING STATIC PRESSURES	34
E. WIRE CONNECTIONS	43
CONNECTION DIAGRAMS.....	44
WIRING DIAGRAMS.....	46
CAPACITY SETTING	49
DIP SWITCH SETTINGS	50
INDOOR UNIT WIRING.....	52
TEST RUN	53
TROUBLESHOOTING	54
DUCTLESS START - UP CHECKLIST - Single Zone.....	55

NOTES: Read the entire instruction manual before starting the installation. Images are for illustration purposes only. Actual models may differ slightly.

SAFETY CONSIDERATIONS

Installing, starting up, and servicing air-conditioning equipment can be hazardous due to system pressures, electrical components, and equipment location (roofs, elevated structures, etc.).

Only trained, qualified installers and service mechanics should install, start-up, and service this equipment.

Untrained personnel can perform basic maintenance functions such as coil cleaning. All other operations should be performed by trained service personnel only.

When working on the equipment, observe the precautions in the literature and on tags, stickers, and labels attached to the equipment.

Follow all safety codes. Wear safety glasses and work gloves. Keep a quenching cloth and a fire extinguisher nearby when brazing. Use care in handling, rigging, and setting bulky equipment.

Read these instructions thoroughly and follow all warnings or cautions included in the literature and attached to the unit. Consult local building codes and National Electrical Code (NEC) for special requirements. Recognize safety information.

This is the safety - alert symbol .

When you see this symbol on the unit and in instructions or manuals, be alert to the potential for personal injury. Understand these signal words: **DANGER**, **WARNING**, and **CAUTION**. These words are used with the safety- alert symbol.



DANGER identifies the most serious hazards which will result in severe personal injury or death.

WARNING signifies hazards which could result in personal injury or death.

CAUTION is used to identify unsafe practices which may result in minor personal injury or product and property damage.

NOTE is used to highlight suggestions which will result in enhanced installation, reliability, or operation.

 WARNING	
ELECTRICAL SHOCK HAZARD	
Failure to follow this warning could result in personal injury or death.	
Before installing, modifying, or servicing system, the main electrical disconnect switch must be in the OFF position. There may be more than 1 disconnect switch. Lock out and tag switch with a suitable warning label.	

 WARNING	
	EXPLOSION HAZARD
	Failure to follow this warning could result in death, serious personal injury, and/or property damage.
	Never use air or gases containing oxygen for leak testing or operating refrigerant compressors. Pressurized mixtures of air or gases containing oxygen can lead to an explosion.

 CAUTION	
EQUIPMENT DAMAGE HAZARD	
Failure to follow this caution may result in equipment damage or improper operation.	
Do not bury more than 36 in. (914 mm) of refrigerant pipe in the ground. If any section of pipe is buried, there must be a 6 in. (152 mm) vertical rise to the valve connections on the outdoor units. If more than the recommended length is buried, refrigerant may migrate to the cooler buried section during extended periods of system shutdown. This causes refrigerant slugging and could possibly damage the compressor at start-up.	

 WARNING	
This appliance is not intended for use by persons (including children) with reduced physical, sensory or mental capabilities, or lack of experience and knowledge, unless they have been given supervision or instruction concerning use of the appliance by a person responsible for their safety. Children should be supervised to ensure that they do not play with the appliance.	

 WARNING	
Only use the specified wire. If the wire is damaged, it must be replaced by the manufacturer, its service agent or similarly qualified persons in order to avoid a hazard. The product must be properly grounded at the time of installation, or electric shock may occur.	
For all electrical work, follow all local and national wiring standards, regulations, and the Installation Manual. Connect the cables tightly, and clamp them securely to prevent external forces from damaging the terminal. Improper electrical connections can overheat and cause fire, and may also cause shock. All electrical connections must be made according to the Electrical Connection Diagram located on the panels of the indoor and outdoor units.	
All wiring must be properly arranged to ensure that the control board cover can close properly. If the control board cover is not closed properly, it can lead to corrosion and cause the connection points on the terminal to heat up, catch fire, or cause electrical shock.	
Disconnection must be incorporated in the fixed wiring in accordance with NEC, CSA and Local Codes. Do not share the electrical outlet with other appliances. Improper or insufficient power supply can cause fire or electric shock.	
If connecting power to fixed wiring, an all-pole disconnection device which has at least 3mm clearances in all poles, and have a leakage current that may exceed 10mA, the residual current device (RCD) having a rated residual operating current not exceeding 30mA, and disconnection must be incorporated in the fixed wiring in accordance with NEC, CSA and Local Codes.	

⚠ WARNING

Turn off the air conditioner and disconnect the power before performing any installation or repairing. Failure to do so can cause electric shock.

Installation must be performed by an authorized dealer or specialist. Defective installation can cause water leakage, electrical shock, or fire. Installation must be performed according to the installation instructions.

Improper installation can cause water leakage, electrical shock, or fire. Contact an authorized service technician for repair or maintenance of this unit. This appliance shall be installed in accordance with national wiring regulations.

Only use the included accessories, parts, and specified parts for installation. Using non-standard parts can cause water leakage, electrical shock, fire, and can cause the unit to fail.

Install the unit in a firm location that can support the unit's weight. If the chosen location cannot support the unit's weight, or the installation is not done properly, the unit may drop and cause serious injury and damage. Install drainage piping according to the instructions in this manual. Improper drainage may cause water damage to your home and property. For units that have an auxiliary electric heater, do not install the unit within 3 feet (1 meter) of any combustible materials.

If combustible gas accumulates around the unit, it may cause fire. Do not turn on the power until all work has been completed.

When moving or relocating the air conditioner, consult experienced service technicians for disconnection and re-installation of the unit.

Read the information for details in "indoor unit installation" and "outdoor unit installation" sections.

NOTE: The air conditioner's circuit board (PCB) is designed with a fuse to provide overcurrent protection. The specifications of the fuse are printed on the circuit board, for example: T3.15AL/250VAC, T5AL/250VAC, T3.15A/250VAC, T5A/250VAC, T20A/250VAC, T30A/250VAC, etc.

NOTE: Only a blast-proof ceramic fuse can be used.





⚠ WARNING

PERSONAL INJURY AND PROPERTY DAMAGE HAZARD

For continued performance, reliability, and safety, the only approved accessories and replacement parts are those specified by the equipment manufacturer. The use of non-manufacturer approved parts and accessories could invalidate the equipment limited warranty and result in a fire risk, equipment malfunction, and failure.

Please review the manufacturer's instructions and replacement parts catalogs available from your equipment supplier.

Table 1 — Symbols displayed on the indoor unit or outdoor unit

	WARNING	This symbol shows that this appliance used a flammable refrigerant. If the refrigerant is leaked and exposed to an external ignition source, there is a risk of fire.
	CAUTION	This symbol shows that the operation manual should be read carefully.
	CAUTION	This symbol shows that a service personnel should be handling this equipment with reference to the installation manual.
	CAUTION	
	CAUTION	This symbol shows that information is available such as the operating manual or installation manual.

⚠ WARNING

FOR FLAMMABLE REFRIGERANTS

Do not use means to accelerate the defrosting process or to clean, other than those recommended by the manufacturer.

The appliance shall be stored in a room without continuously operating ignition sources (for example: open flames, an operating gas appliance or an operating electric heater).

Do not pierce or burn. Be aware that refrigerants may not contain an odor.

R-454B  Refrigerant Safety Group **A2L** R-454B

WARNING - Risk of Fire due to Flammable Refrigerant Used. Follow Handling Instructions Carefully in Compliance with National Regulations

NOTE: Risk of Fire. Flammable refrigerant used. To be repaired only by trained service personnel. Do not puncture refrigerant tubing.

Table 2 — A (min)

	Mc or Mrel (lbs(kgs))	Ho, release height ft (m)					
		≤ 7.2 (2.2)	7.5 (2.3)	7.9 (2.4)	8.5 (2.6)	9.2 (2.8)	9.8 (3.0)
MC or Mrel Refrigerant Charge Amount pounds (kilograms)	≤ 3.91 (1.776)	12 (1.10)					
	4.0 (1.8)	60 (5.53)	57 (5.29)	55 (5.07)	50 (4.68)	47 (4.34)	44 (4.05)
	4.4 (2.0)	66 (6.14)	63 (5.88)	61 (5.63)	56 (5.2)	52 (4.83)	48 (4.5)
	4.9 (2.2)	73 (6.76)	70 (6.46)	67 (6.19)	62 (5.72)	57 (5.31)	53 (4.95)
	5.3 (2.4)	79 (7.37)	76 (7.05)	73 (6.76)	67 (6.24)	62 (5.79)	58 (5.41)
	5.7 (2.6)	86 (7.99)	82 (7.64)	79 (7.32)	73 (6.76)	68 (6.27)	63 (5.86)
	6.2 (2.8)	93 (8.6)	89 (8.23)	85 (7.88)	78 (7.28)	73 (6.76)	68 (6.31)
	6.6 (3.0)	99 (9.21)	95 (8.81)	91 (8.45)	84 (7.8)	78 (7.24)	73 (6.76)
	7.1 (3.2)	106 (9.83)	101 (9.4)	97 (9.01)	90 (8.32)	83 (7.72)	78 (7.21)
	7.5 (3.4)	112 (10.44)	108 (9.99)	103 (9.57)	95 (8.84)	88 (8.2)	82 (7.66)
	7.9 (3.6)	119 (11.06)	114 (10.58)	109 (10.14)	101 (9.36)	94 (8.69)	87 (8.11)
	8.4 (3.8)	126 (11.67)	120 (11.16)	115 (10.7)	106 (9.88)	99 (9.17)	92 (8.56)
	8.8 (4.0)	132 (12.29)	126 (11.75)	121 (11.26)	112 (10.4)	104 (9.65)	97 (9.01)
	9.3 (4.2)	139 (12.9)	133 (12.34)	127 (11.82)	117 (10.91)	109 (10.14)	102 (9.46)
	9.7 (4.4)	145 (13.51)	139 (12.93)	133 (12.39)	123 (11.43)	114 (10.62)	107 (9.91)
	10.1 (4.6)	152 (14.13)	145 (13.51)	139 (12.95)	129 (11.95)	119 (11.1)	112 (10.36)
	10.6 (4.8)	159 (14.74)	152 (14.1)	145 (13.51)	134 (12.47)	125 (11.58)	116 (10.81)
	11 (5.0)	165 (15.36)	158 (14.69)	152 (14.08)	140 (12.99)	130 (12.07)	121 (11.26)
	11.5 (5.2)	172 (15.97)	164 (15.28)	158 (14.64)	145 (13.51)	135 (12.55)	126 (11.71)
	11.9 (5.4)	179 (16.58)	171 (15.86)	164 (15.2)	151 (14.03)	140 (13.03)	131 (12.16)
12.3 (5.6)	185 (17.2)	177 (16.45)	170 (15.77)	157 (14.55)	145 (13.51)	136 (12.61)	
12.8 (5.8)	192 (17.81)	183 (17.04)	176 (16.33)	162 (15.07)	151 (14)	141 (13.06)	
13.2 (6.0)	198 (18.43)	190 (17.63)	182 (16.89)	168 (15.59)	156 (14.48)	145 (13.51)	
13.7 (6.2)	205 (19.04)	196 (18.21)	188 (17.45)	173 (16.11)	161 (14.96)	150 (13.96)	
14.1 (6.4)	212 (19.66)	202 (18.8)	194 (18.02)	179 (16.63)	166 (15.44)	155 (14.41)	
14.6 (6.6)	218 (20.27)	209 (19.39)	200 (18.58)	185 (17.15)	171 (15.93)	160 (14.86)	
15 (6.8)	225 (20.88)	215 (19.98)	206 (19.14)	190 (17.67)	177 (16.41)	165 (15.32)	
15.4 (7.0)	231 (21.5)	221 (20.56)	212 (19.71)	196 (18.19)	182 (16.89)	170 (15.77)	
15.9 (7.2)	238 (22.11)	228 (21.15)	218 (20.27)	201 (18.71)	187 (17.37)	175 (16.22)	
Amin (ft2 (m2)) Mc - Actual refrigerant charge in the system lbs (Kg) Mrel - Refrigerant releasable charge lbs (kg) Ho - Release height, measured from duct opening, in ft (m) Hinst - Height of install, from the bottom of the indoor appliance, measured in ft (m) Ho ≈ Hinst Warning: Minimum room area of conditioned space is based on releasable charge or total system refrigerant charge.							

For R454B refrigerant charge amount and minimum room area:

The indoor unit should be installed at least 5.9ft/1.8m above the floor, and the minimum room area for operation or storage should be as specified in Table 2.

NOTE: For units installed in the conditioned space, users may need to adjust temperatures compensations for sensed space temperature.
Configuration found in IR remote manual for parameter setting.

Room Size Restriction

The appliances are connected via an air duct system to one or more rooms. The bottom of the air inlet of the air duct should be at a height > 7.3ft/2.2m from the floor. In UL/CSA 60335-2-40 the refrigerant belongs to mildly flammable refrigerants which will limit the room area of the system service. Similarly, the total amount of refrigerant in the system should be less than or equal to the maximum allowable refrigerant charge, which depends on the room area services by the system.

Table 3 — Airflow Information

MODEL	09K	12K	18K	24K	36K	48K	60K
NOMINAL AIR VOLUME CFM (M ³ /H)	324 (550)	382 (650)	647 (1100)	824 (1400)	1176 (2000)	1588 (2700)	2000 (3400)

Table 4 — Compatible Models

CAPACITY	INDOOR	OUTDOOR
06K	45MBDAQ06XA3	37MAHAQ06AA3
09K/12K	45MBDAQ12XA3 45MBDAQ12XH3	37MAHAQ09AA3
		37MAHAQ12AA3
		37MARAQ09AA3
		37MARAQ12AA3
18K	45MBDAQ18XA3 45MBDAQ18XH3	37MAHAQ18AA3
		37MARAQ18AA3
24K	45MBDAQ24XH3	37MAHAQ24AA3
		37MARAQ24AA3
36K	45MBDAQ36XH3	37MBHAQ36AA3
		37MBRAQ36AA3
48K	45MBDAQ48XH3	37MBHAQ48AA3
		37MBRAQ48AA3
58K	45MBDAQ58XH3	37MBHAQ58AA3
		37MBRAQ58AA3

1. Installation (where refrigerant pipes are allowed)

Any person who is involved with working on or breaking into a refrigerant circuit should hold a current valid certificate from an industry-accredited assessment authority, which authorizes their competence to handle refrigerants safely in accordance with an industry recognized assessment specification.

Maintenance and repair requiring the assistance of other skilled personnel shall be carried out under the supervision of the person competent in the use of flammable refrigerants.

The installation of pipe-work shall be kept to a minimum.

Pipe-work shall be protected from physical damage. Where refrigerant pipes shall be compliance with national gas regulations. That mechanical connections shall be accessible for maintenance purposes.

Be more careful that foreign matter (oil, water, etc.) does not enter the piping. When storing the piping, securely seal the opening by pinching, taping, etc. All working procedure that affects safety means shall only be carried by competent persons.

Appliance shall be stored in a well ventilated area where the room size corresponds to the room area as specific for operation.

Joints shall be tested with detection equipment with a capability of 1/8 oz (5g)/year of refrigerant or better, with the equipment in standstill and under operation or under a pressure of at least these standstill or operation conditions after installation. In cases that require mechanical ventilation, ventilation openings shall be kept clear of obstruction.

LEAK DETECTION SYSTEM installed. Unit must be powered except for service. For the unit with refrigerant sensor, when the refrigerant sensor detects refrigerant leakage, the indoor unit displays a error code and emit a buzzing sound, the compressor of outdoor unit immediately stops, and the indoor fan starts running. The service life of the refrigerant sensor is 15 years. When the refrigerant sensor malfunctions, the indoor unit displays the error code **FHCC**. Refer to the error code table in the unit's service manual for details. The refrigerant sensor can not be repaired and can only be replaced by the manufacture. It shall only be replaced with the sensor specified by the manufacture.

2. Because a **FLAMMABLE REFRIGERANT** is used, the requirements for installation space of appliance and/or ventilation requirements are determined according to:
 - the refrigerant charge used in the appliance,
 - the installation location,
 - the type of ventilation of the location or of the appliance.
 - piping material, pipe routing, and installation shall include protection from physical damage in operation and service, and be in compliance with national and local codes and standards, such as ASHRAE 15, IAPMO Uniform Mechanical Code, ICC International Mechanical Code, or CSA B52. All field joints shall be accessible for inspection prior to being covered or enclosed.
 - that protection devices, piping, and fittings shall be protected as far as possible against adverse environmental effects, for example, the danger of water collecting and freezing in relief pipes or the accumulation of dirt and debris;
 - that piping in refrigeration systems is designed and installed to minimize the likelihood of hydraulic shock damaging the system;
 - that steel pipes and components shall be protected against corrosion with a rustproof coating before applying any insulation;
 - that precautions shall be taken to avoid excessive vibration or pulsation;
 - the minimum floor area of the room shall be mentioned in the form of a table or a single figure without reference to a formula;
 - after completion of field piping for split systems, the field pipework shall be pressure tested with an inert gas and then vacuum tested prior to refrigerant charging, according to the following requirements:

- a. The required nitrogen test pressure is 500 PSI.
- b. The test pressure after removal of pressure source shall be maintained for at least 1 hour with no decrease of pressure indicated by the test gauge, with test gauge resolution not exceeding 5% of the test pressure.
- c. During the evacuation test, after achieving a vacuum level specified in the manual or less, the refrigeration system shall be isolated from the vacuum pump and the pressure shall not rise above 1500 microns within 10 min. The vacuum pressure level shall be specified in the manual, and shall be the lessor of 500 microns or the value required for compliance with national and local codes and standards, which may vary between residential, commercial, and industrial buildings.
 - Field-made refrigerant joints indoors shall be tightness tested according to the following requirements: The test method shall have a sensitivity of 1/8 oz (5 g) per year of refrigerant or better under a pressure of at least 125% of the maximum allowable pressure. No leak shall be detected.

3. Qualification of Workers

Any maintenance, service and repair operations must be performed by skilled and authorized personnel. Every working procedure that affects safety means shall only be carried out by competent persons that joined the training and achieved competence should be documented by a certificate. The training of these procedures is carried out by national training organizations or manufacturers that are accredited to teach the relevant national competency standards that may be set in legislation. Examples for such working procedures are:

- breaking into the refrigerating circuit;
- opening of sealed components;
- opening of ventilated enclosures.

4. Ventilated Area

Ensure that the area is in the open or that it is adequately ventilated before breaking into the system or conducting any hot work. A degree of ventilation shall continue during the period that the work is carried out. The ventilation should safely disperse any released refrigerant and preferably expel it externally into the atmosphere.

5. Cabling

Check that cabling is not subjected to wear, corrosion, excessive pressure, vibration, sharp edges or any other adverse environmental effects. The check shall also take into account the effects of aging or continual vibration from sources such as compressors or fans.

6. Detection of Flammable Refrigerants

Under no circumstances shall potential sources of ignition be used in the searching for or detection of refrigerant leaks. A halide torch (or any other detector using a naked flame) shall not be used. The following leak detection methods are deemed acceptable for refrigerant systems. Electronic leak detectors that have a sensitivity of 1/8 Oz (5g)/year may be used to detect leaks of flammable refrigerants. (Detection equipment shall be calibrated in a refrigerant free area.) Ensure that the detector is not a potential source of ignition and is suitable for the refrigerant used. Leak detection equipment shall be set at a percentage of the LFL of the refrigerant and shall be calibrated to the refrigerant employed, and the appropriate percentage of gas (25% maximum) is confirmed. Leak detection fluids are also suitable for use in external leak detection.

NOTE: Examples of leak detection fluids are

- bubble method,
- fluorescent method agents.

If a leak is suspected, all open flames shall be removed/extinguished. If a leakage of refrigerant is found which requires brazing, all of the refrigerant shall be recovered from the system, or isolated (by means of shut off valves) in a part of the system remote from the leak. See the following instructions of removal of refrigerant.

7. Evacuation

When breaking into the refrigerant circuit to make repairs - or for any other purpose conventional procedures shall be used. However, for flammable refrigerants it is important that best practice be followed, since flammability is a consideration. The following procedure shall be adhered to:

- safely recover refrigerant following local and national regulations; evacuate;
- purge the circuit with NITROGEN;
- evacuate (requirement);
- continuously flush or purge with NITROGEN when using flame to open circuit; and
- open the circuit

The refrigerant charge shall be recovered into the correct recovery cylinders. Charging must be performed by the liquid charging method. For appliances containing flammable refrigerants, the system shall be purged with oxygen-free nitrogen to render the appliance safe for flammable refrigerants. This process might need to be repeated several times. Compressed air or oxygen shall not be used for purging refrigerant systems.

For appliances containing flammable refrigerants, refrigerants purging shall be achieved by breaking the vacuum in the system with oxygen-free nitrogen and continuing to fill until the working

pressure is achieved, then venting to atmosphere, and finally pulling down to a vacuum (requirement). This process shall be repeated until no refrigerant is within the system (requirement). When the final oxygen-free nitrogen charge is used, the system shall be vented down to atmospheric pressure to enable work to take place. The outlet for the vacuum pump shall not be close to any potential ignition sources, and ventilation shall be available.

Recovery: When removing refrigerant from a system, either for servicing or decommissioning, it is recommended good practice that all refrigerants are removed safely.

When transferring refrigerant into cylinders, ensure that only appropriate refrigerant recovery cylinders are employed. Ensure that the correct number of cylinders for holding the total system charge is available. All cylinders to be used are designated.

8. Charging Procedures

In addition to conventional charging procedures, the following requirements shall be followed:

Works shall be undertaken with appropriate tools only (in case of uncertainty, consult the manufacturer of the tools for use with flammable refrigerants)

Ensure that contamination of different refrigerants does not occur when using charging equipment. Hoses or lines shall be as short as possible to minimize the amount of refrigerant contained in them. Charging must be performed by the liquid charging method.

Ensure that the refrigeration system is grounded prior to charging the system with refrigerant.









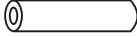

Label the system when charging is complete (if not already).

Extreme care shall be taken not to overfill the refrigeration system. Prior to recharging the system it shall be pressure tested with oxygen free nitrogen (OFN). The system shall be leak tested on completion of charging but prior to commissioning. A follow up leak test shall be carried out prior to leaving the site.

ACCESSORIES

The system is shipped with the following accessories. Use all of the installation parts and accessories to install the system. Improper installation may result in water leakage, electrical shock and fire, or cause the equipment to fail. Keep the installation manual in a safe place and do not discard any other accessories until the installation has been completed.

Table 5 — Accessories

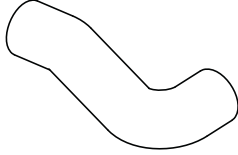
NAME	SHAPE	QTY
Manual		2-4
Refrigerant In/Out Pipe Protection Cover		2
Copper Nut		2
Wired Remote Controller (with packing)		1
Outlet Pipe Sheath		1
Outlet Pipe Clasp		2
Magnetic Ring (for wired controller connector)		1
Magnetic Ring (Hitch it on the connective cable between the indoor unit and outdoor unit after installation.)		1
Display Panel		1
Remote Controller and Battery		1
		2
Remote Controller Holder		1
Drain Hose*		1

NOTE: Drain Hose is for 06K, 09K, 12K, 18K low static duct ONLY.*

Optional Accessories

- The 1201 Wired Controller for basic timer only operation
- The 24 volt interface for third party thermostat operation

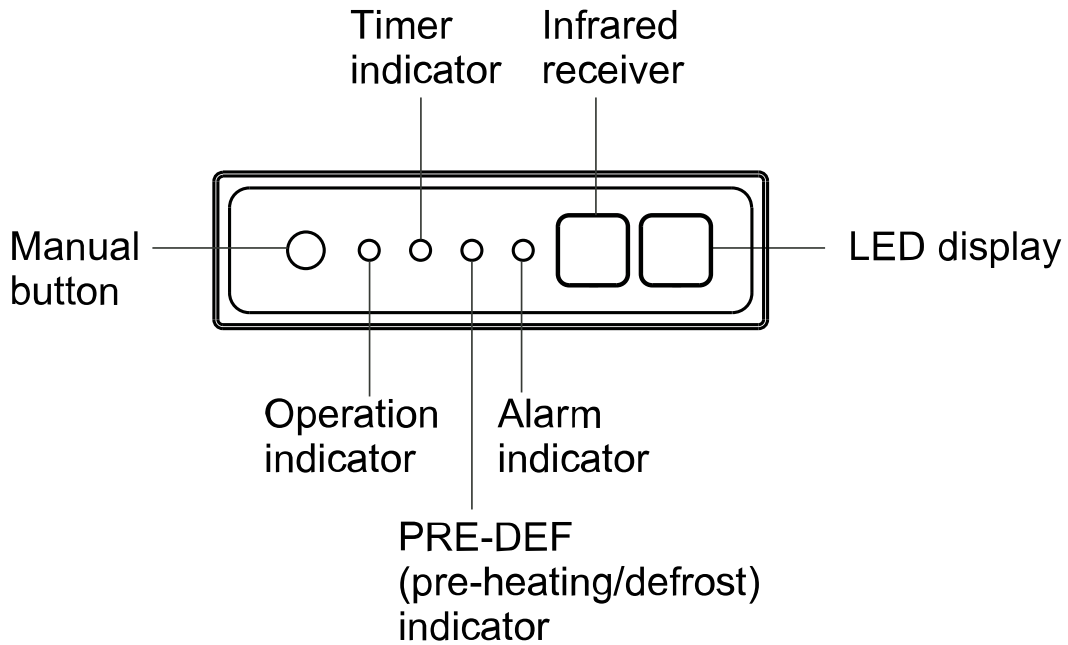

Fig. 3 — Display Panel

MANUAL button: This button selects the mode in the following order: **AUTO**, **FORCED COOL**, **OFF**.

FORCED COOL mode: In **FORCED COOL** mode, the Operation light flashes. The system will then turn to **AUTO** after it has cooled with a high wind speed for 30 minutes. The remote control will be disabled during this operation.

OFF mode: When the display panel is turned **OFF**, the unit turns off and the remote control is re-enabled.

Table 6 — Pipe Specification

NAME	MODEL	SPECIFICATION		REMARK
		LIQUID SIDE	GAS SIDE	
Connecting Pipe Assembly	06k	6.35mm(1/4in)	9.52mm(3/8in)	Parts must be purchased separately. Consult your dealer about the proper pipe size of the unit you purchased
	09K/12K	6.35mm(1/4in)	9.52mm(3/8in)	
	18K	6.35mm(1/4in)	12.7mm(1/2in)	
	24K	9.52mm(3/8in)	15.9mm(5/8in)	
	36K	9.52mm(3/8in)	19mm(3/4in)	
	48K	9.52mm(3/8in)	19mm(3/4in)	
	58K	9.52mm(3/8in)	19mm(3/4in)	

Table 7 — Indoor Model Numbers

SYSTEM TONS	BTUH	VOLTAGE	MODEL
0.5	6,000	208/230-1	45MBDAQ06XA3
0.75/1.0	9,000/12,000	208/230-1	45MBDAQ12XA3
1.5	18,000	208/230-1	45MBDAQ18XA3
0.75/1.0	9,000/12,000	208/230-1	45MBDAQ12XH3
1.5	18,000	208/230-1	45MBDAQ18XH3
2.0	24,000	208/230-1	45MBDAQ24XH3
3.0	36,000	208/230-1	45MBDAQ36XH3
4.0	48,000	208/230-1	45MBDAQ48XH3
4.8	58,000	208/230-1	45MBDAQ58XH3

DIMENSIONS AND WEIGHTS

Table 8 — Dimensions and Weights (Heat Pump Models) Low Static

SYSTEM SIZE		06K	09K/12K	18K
		(208/230 V)	(208/230 V)	(208/230 V)
Height (H)	in (mm)	7.87(200)	7.87(200)	8.27(210)
Width (W)	in (mm)	27.56(700)	27.56(700)	34.65(880)
Depth (D)	in (mm)	19.92(506)	19.92(506)	26.54(674)
Weight -Net	lbs. (kg)	39.46(17.9)	39.46(17.9)	54.45(24.7)
Packaging				
Height	in (mm)	10.83(275)	10.83(275)	11.02(280)
Width	in (mm)	42.13(1070)	42.13(1070)	42.13(1070)
Depth	in (mm)	21.26(540)	21.26(540)	28.54(725)
Weight-Gross	lbs. (kg)	46.74(21.2)	46.74(21.2)	66.14(30)
Carton Drawing No.	--	ZXW-1055*525*260S-NS1K	ZXW-1055*525*260S-NS1K	ZXW-1055*710*255S-NS1
Carton Material	--	Double corrugated cardboard		
Material Thickness	in (mm)	0.295(7.5)	0.295(7.5)	0.295(7.5)

Table 9 — Dimensions and Weights (Heat Pump Models) High Static

SYSTEM SIZE		09K/12K	18K	24K	36K	48K	60K
		(208/230 V)	(208/230 V)	(208/230 V)	(208/230 V)	(208/230 V)	(208/230 V)
Height (H)	in (mm)	9.65(245)	9.65(245)	9.65(245)	11.81(300)	11.81(300)	14.96(380)
Width (W)	in (mm)	27.56(700)	39.37(1000)	39.37(1000)	47.24(1200)	47.24(1200)	55.12(1400)
Depth (D)	in (mm)	29.53(750)	29.53(750)	29.53(750)	29.53(750)	29.53(750)	31.50(800)
Weight -Net	lbs. (kg)	64.15(29.1)	79.81(36.2)	80.47(36.5)	106.26(48.2)	111.33(50.5)	161.38(73.2)
Packaging							
Height	in (mm)	11.73(298)	11.97(304)	11.97(304)	14.13(359)	14.13(359)	17.52(445)
Width	in (mm)	36.42(925)	48.23(1225)	48.23(1225)	56.10(1425)	56.10(1425)	62.99(1600)
Depth	in (mm)	33.46(850)	33.86(860)	33.86(860)	33.86(860)	33.86(860)	36.02(915)
Weight-Gross	lbs. (kg)	73.85(33.5)	91.27(41.4)	91.93(41.7)	120.37(54.6)	124.78(56.6)	178.13(80.8)
Carton Drawing No.	--	ZXW-910*835*270S-NS1	ZXW-1210*845*280S-NS1	ZXW-1210*845*280S-NS1	ZXW-1410*845*335S-NS1	ZXW-1410*845*335S-NS1	ZXW-1585*900*420S-NS1
Carton Material	--	Double corrugated cardboard					
Material Thickness	in (mm)	0.295(7.5)	0.295(7.5)	0.295(7.5)	0.295(7.5)	0.295(7.5)	0.295(7.5)

PRODUCT OVERVIEW

Illustrations in this manual are for explanatory purposes. The actual shape of your indoor unit may be slightly different. The actual shape shall prevail. The installation must be performed in accordance with the requirement of local and national standards. The installation may be slightly different in different areas.

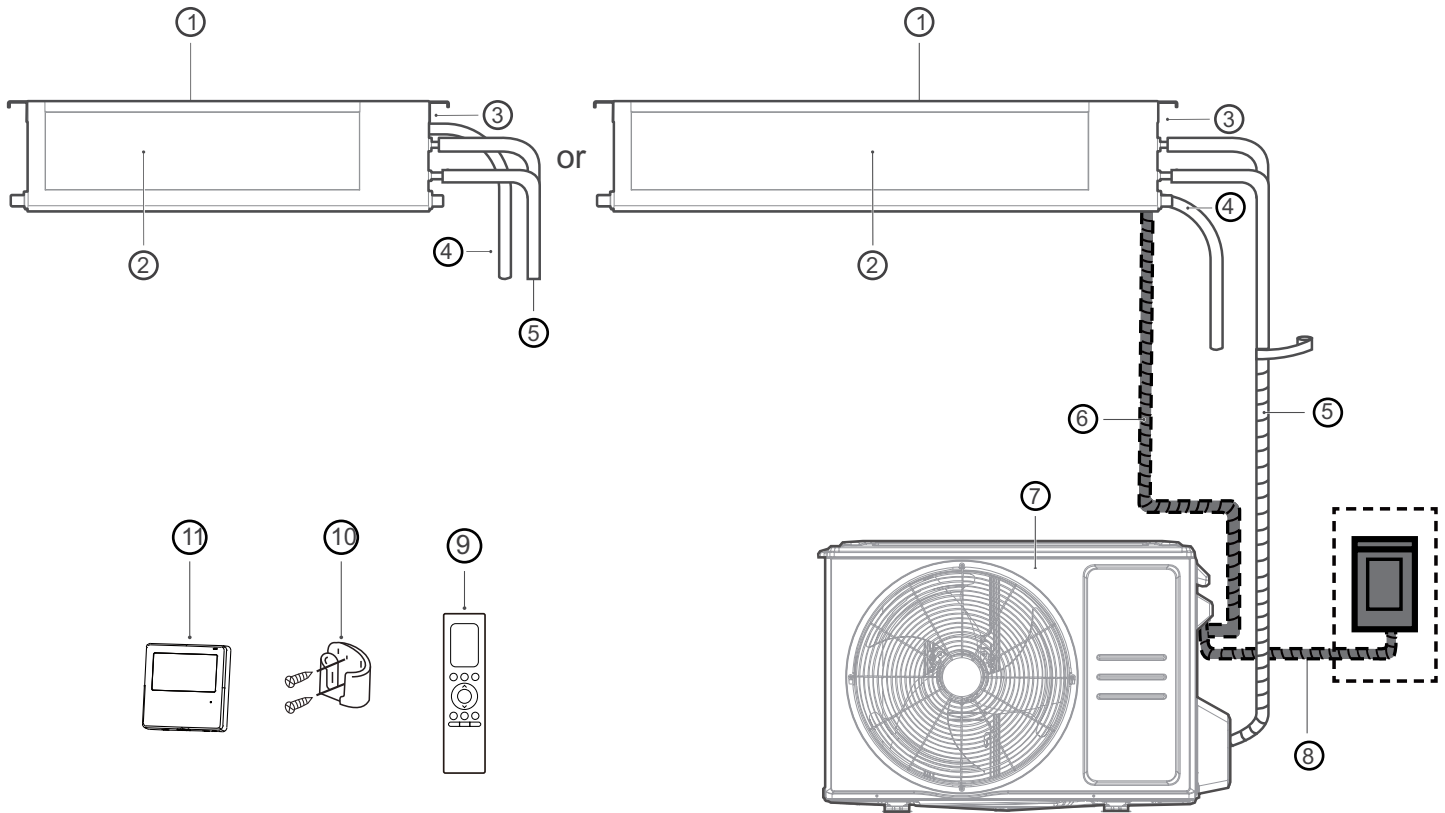

- | | | |
|------------------------|---|----------------------------|
| ① Air inlet | ⑤ Refrigerant Piping
(purchase separately) | ⑨ Remote Controller |
| ② Air outlet | ⑥ Connection cable
(purchase separately) | ⑩ Remote controller holder |
| ③ Electric control box | ⑦ Outdoor Unit | ⑪ Wired remote controller |
| ④ Drain pipe | ⑧ Outdoor unit power cable
(purchase separately) | |

The following tools are recommended:



Gloves



Screwdriver & wrench



Hammer drill

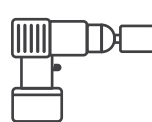

Core drill



Goggles & masks



Vinyl tape

Fig. 4 —Product Overview

INSTALLATION SUMMARY

A

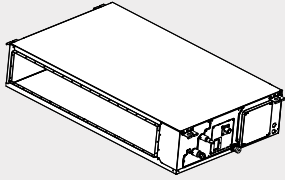

Install the indoor unit

B

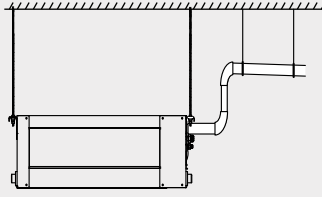

Install the drainpipe

C

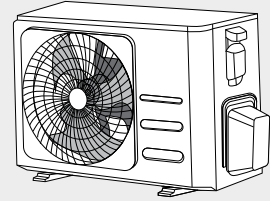

Install the outdoor unit

D

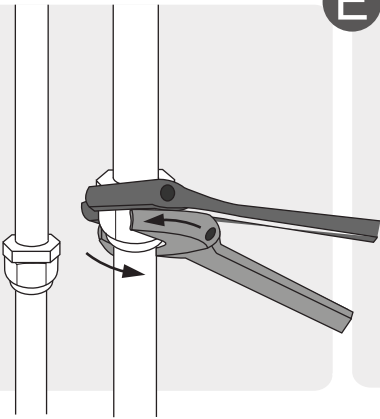

Connect the refrigerant pipes

E

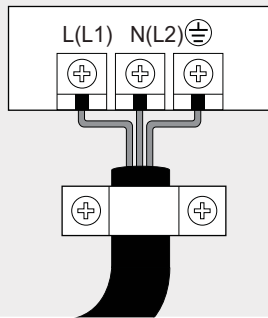

Connect the wires

F

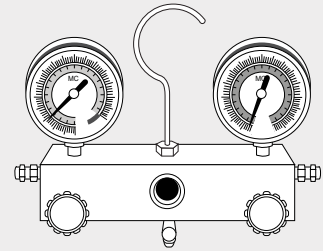

Evacuate the refrigeration system

G

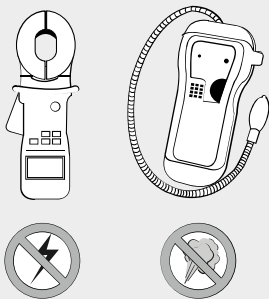

Perform a test run

Fig. 5 —Installation Summary





NOTE: Refer to the outdoor installation manual for steps pertaining to the outdoor unit and system checks.

A. INSTALL THE INDOOR UNIT

Step 1: Select Installation Location

NOTE: Before installing the indoor unit, you must choose an appropriate location. The following are standards that will help you choose an appropriate location for the unit.

Proper installation locations must meet the following standards:

		
<input checked="" type="checkbox"/> Enough room exists for installation and maintenance.	<input checked="" type="checkbox"/> Enough room exists for the connecting the pipe and drainpipe.	<input checked="" type="checkbox"/> There is no direct radiation from heaters.
		
<input checked="" type="checkbox"/> The air inlet and outlet are not blocked.	<input checked="" type="checkbox"/> The airflow can fill the entire room.	<input checked="" type="checkbox"/> The ceiling is horizontal and its structure can sustain the weight of the indoor unit.

For North America, models with a cooling capacity of 6000Btu to 18000Btu only apply to one room.

DO NOT install unit in the following locations:

- | | |
|---|--|
| <ul style="list-style-type: none"> ⊘ Areas with oil drilling or fracking ⊘ Coastal areas with high salt content in the air ⊘ Areas with caustic gases in the air, such as hot springs ⊘ Areas that experience power fluctuations, such as factories | <ul style="list-style-type: none"> ⊘ Enclosed spaces, such as cabinets ⊘ Kitchens that use natural gas ⊘ Areas with strong electromagnetic waves ⊘ Areas that store flammable materials or gas ⊘ Rooms with high humidity, such as bathrooms or laundry rooms |
|---|--|

Fig. 6 —Installation Location Selection

NOTE: For models with a cooling capacity of 6K to 18K only apply to one room. If an 18K indoor unit is equipped with a metal fan wheel metal drain pan and fireproof sheet metal, it can supply multiple rooms.

DIMENSIONS

Low Static

Table 10 — Low Static

MODEL (KBTU/H)	UNIT	A	B	C	C1	D	E	F	G	H	I	J	K	L	M	H1	H2	W1	W2
06 09/12	mm	700	200	470	506	450	137	537	30	152	599	186	50	741	360	84	140	84	84
	inch	27.56	7.87	18.50	19.92	17.72	5.39	21.14	1.18	5.98	23.58	7.32	1.97	29.17	14.17	3.31	5.51	3.31	3.31
18	mm	880	210	634	674	600	140	706	50	136	782	190	50	920	508	78	148	88	112
	inch	34.65	8.27	24.96	26.54	23.62	5.51	27.80	1.97	5.35	30.79	7.48	1.97	36.22	20.00	3.07	5.83	3.46	4.41

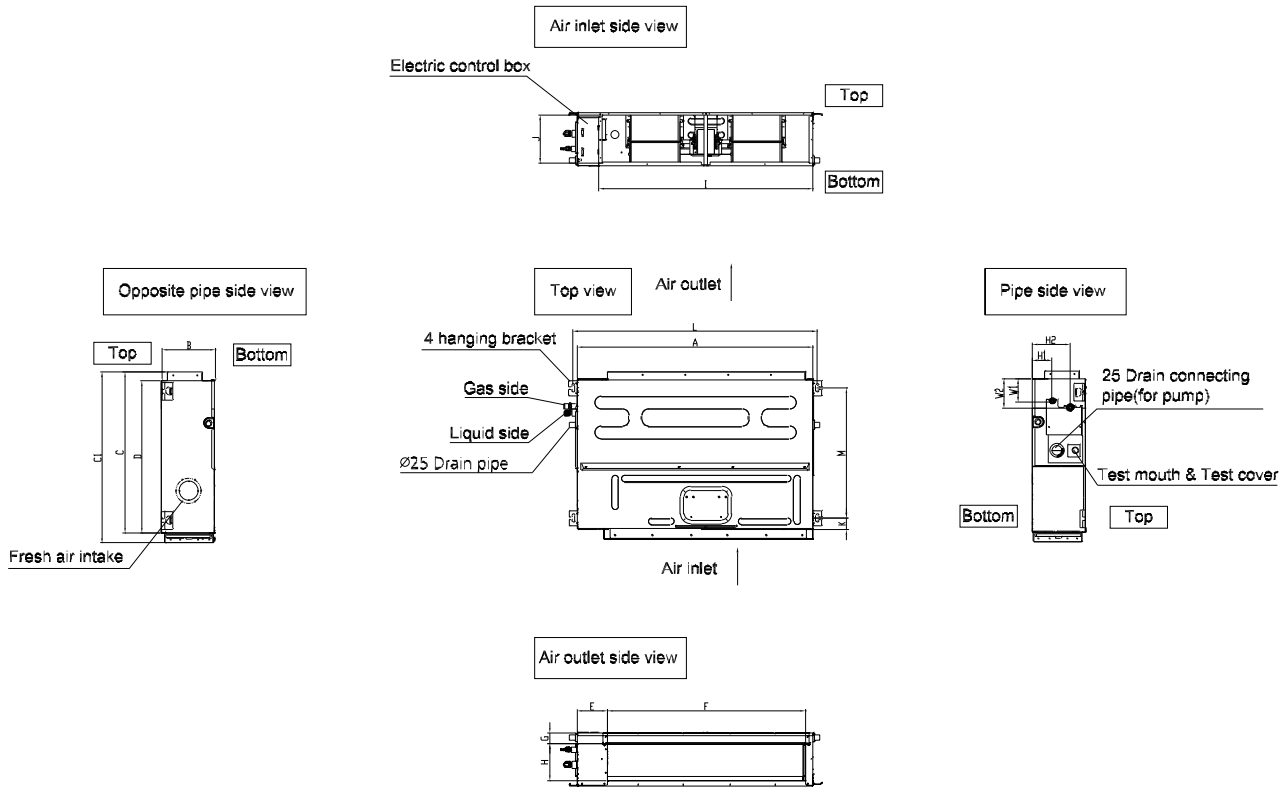

Fig. 7 — Sizes 06K, 09K/12K

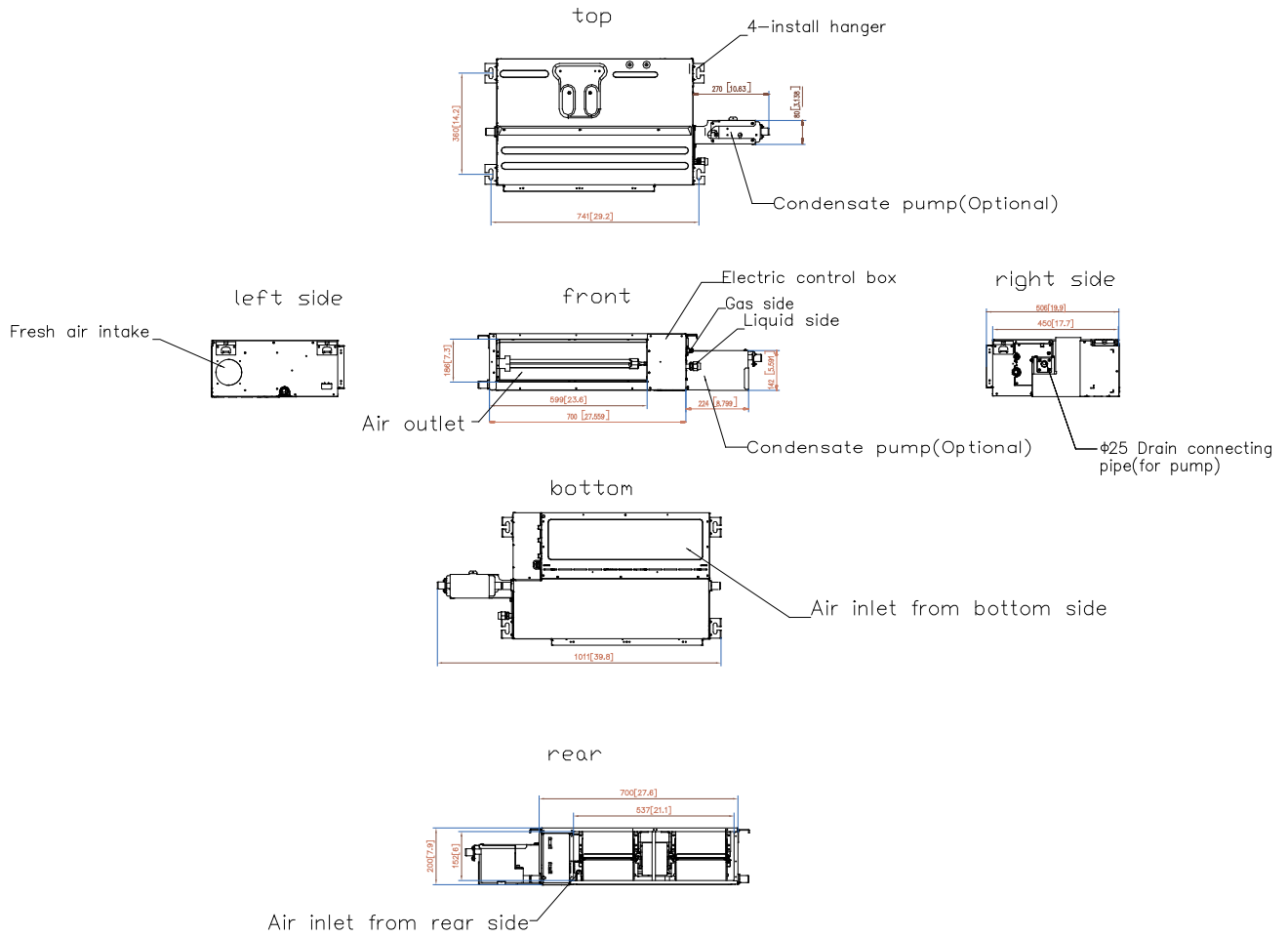

Fig. 8 —Sizes 06K, 09K/12K with external condensate pump (optional) Low Static

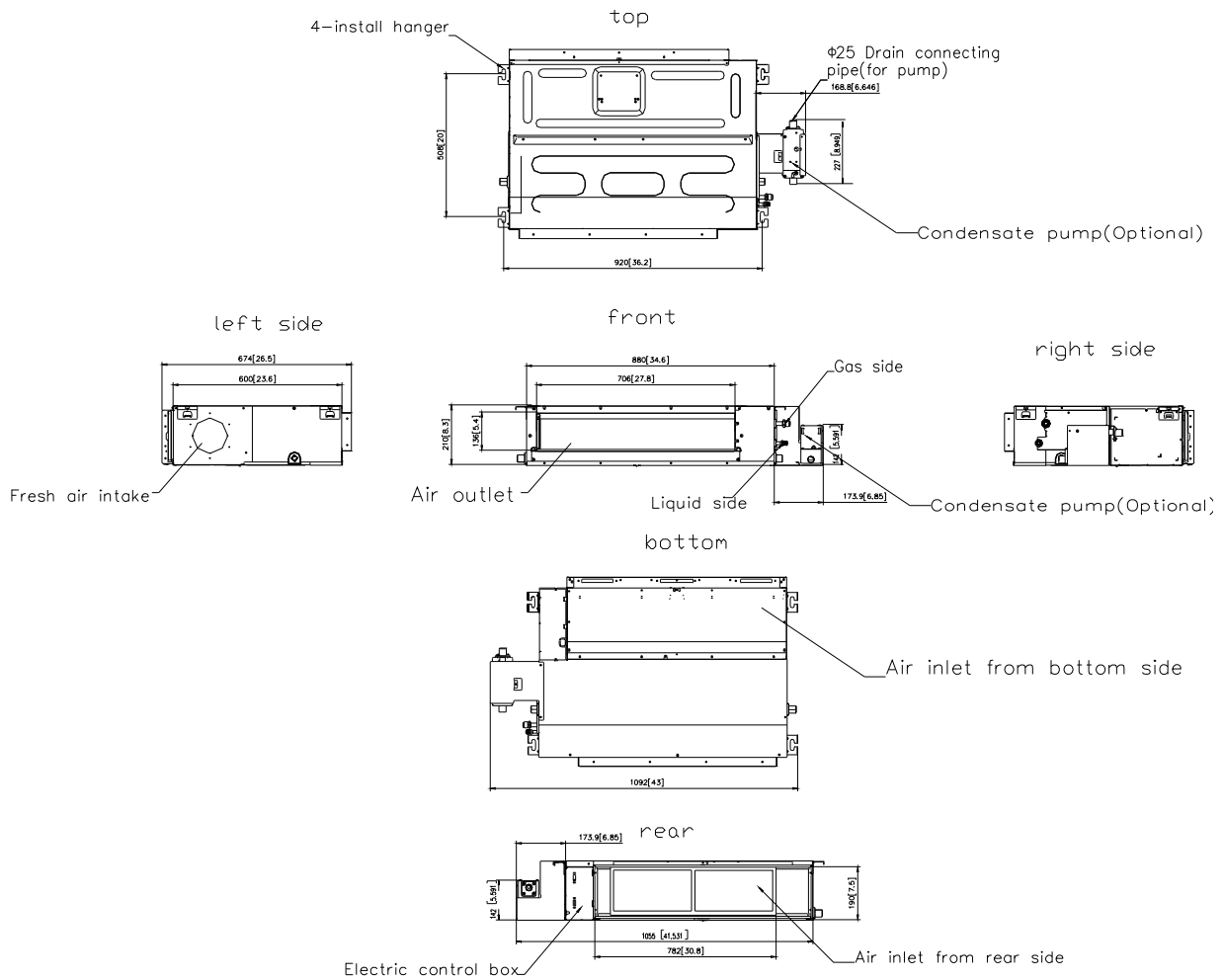

Fig. 9 —Size 18K with external condensate pump (optional) Low Static

High Static

Table 11 — Dimensions

MODEL	UNIT	OUTLINE DIMENSION				AIR OUTLET OPENING SIZE		AIR RETURN OPENING SIZE		SIZE OF MOUNTED LUG		FRESH AIR INTAKE OPENING SIZE	
		A	B	C	D	E	F	G	H	I	J	K	L
09 12	mm	700	245	750	795	527	178	592	212	740	640	100	126
	inch	27.6	9.6	29.5	31.3	20.7	7.0	23.3	8.3	29.1	25.2	3.9	5.0
18	mm	1000	245	750	795	827	178	892	212	1040	640	100	126
24	inch	39.4	9.6	29.5	31.3	32.6	7.0	35.1	8.3	40.9	25.2	3.9	5.0
36 48	mm	1200	300	750	795	1027	233	1092	267	1240	640	125	160
	inch	47.2	11.8	29.5	31.3	40.4	9.2	43.0	10.5	48.8	25.2	4.9	6.3
60	mm	1400	380	800	845	1223	320	1272	330	1440	668	125	160
	inch	55.1	14.9	31.5	33.3	48.1	12.6	50.1	13.0	56.7	26.3	4.9	6.3

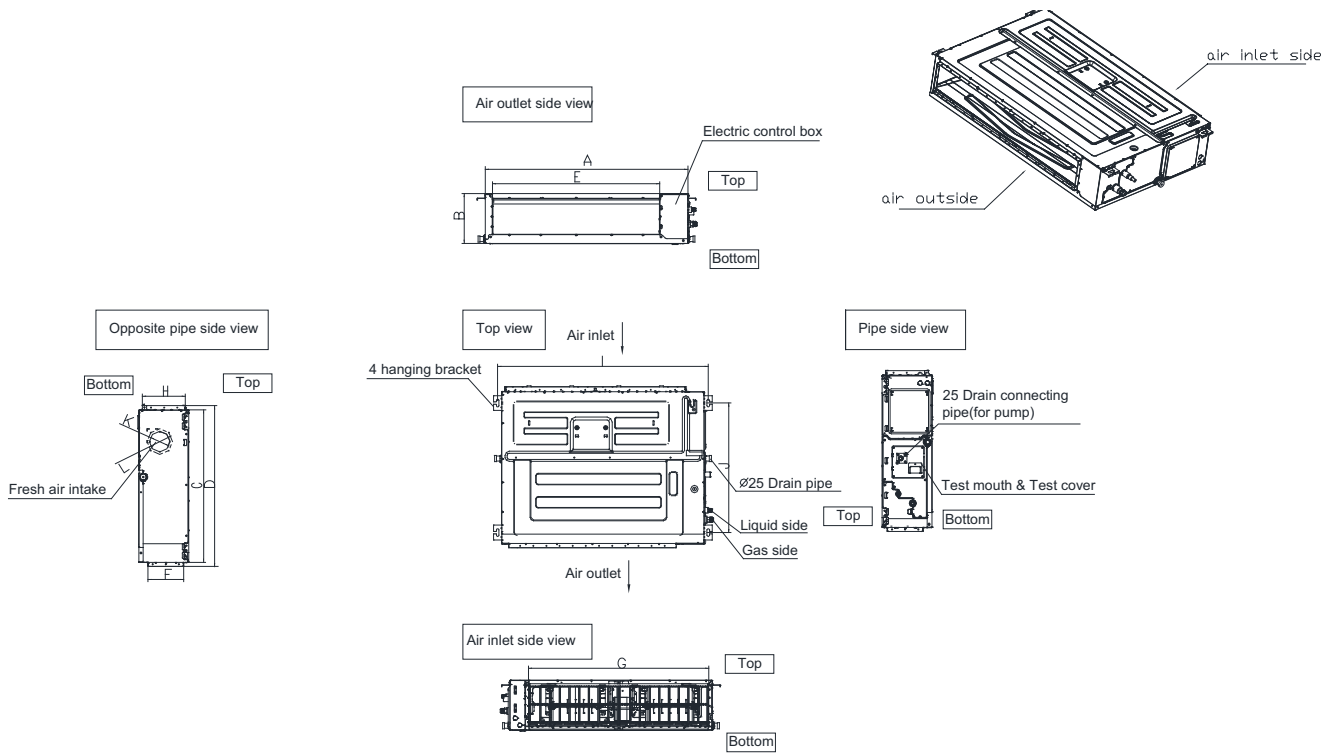

Fig. 10 —Sizes 09K/12K, 18K, 24K, 36K, 48K, 60K High Static

Step 2: Confirm Installation

The distance between the mounted indoor unit should meet the specifications illustrated in Figure 11.

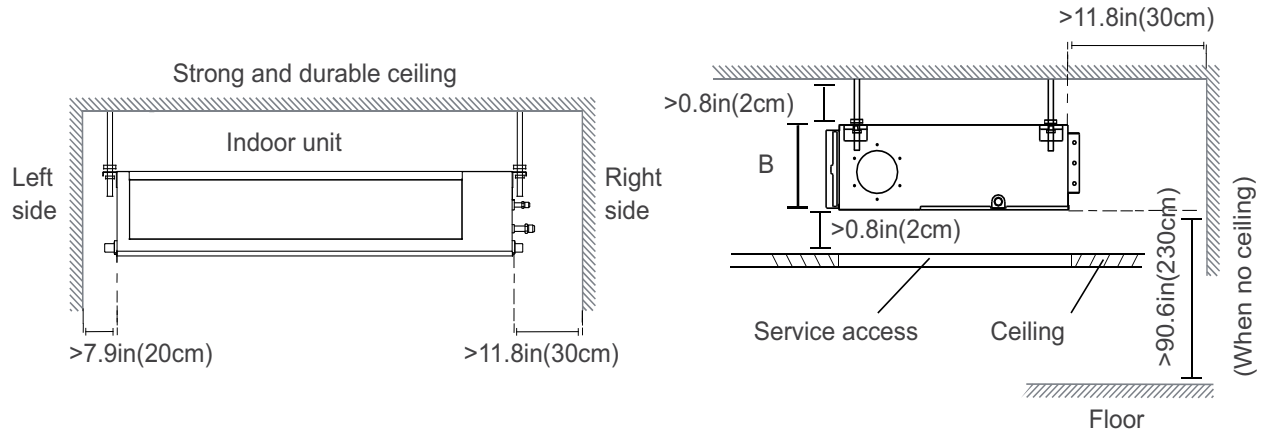

Fig. 11 —Installation Placement

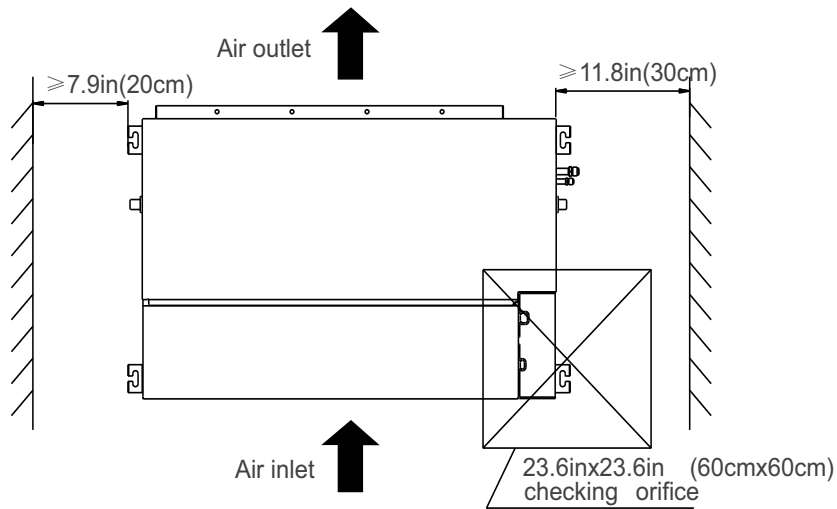
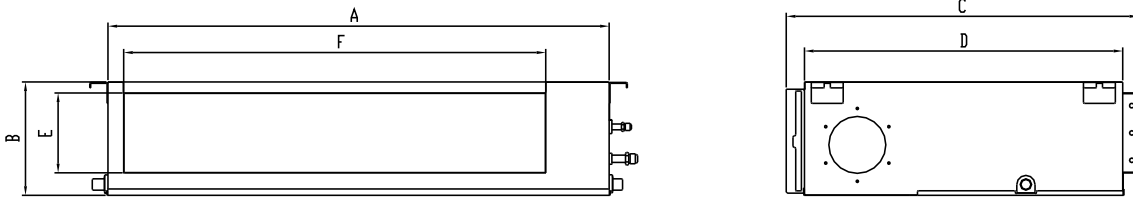

Fig. 12 —Maintenance Space

Step 3: Hang Indoor Unit

Refer to the following diagrams to locate the four positioning screw bolt holes on the ceiling. Be sure to mark the places where you will drill ceiling hook holes.

Air outlet dimensions



Air inlet dimensions

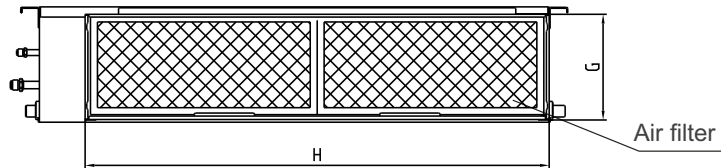

Descending ventilation opening and mounted hook

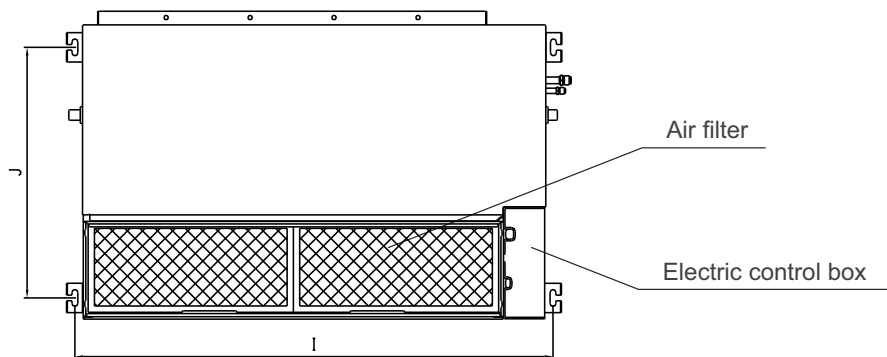

Fig. 13 —Hanging Indoor Unit

Table 12 — Dimensions

MODEL (BTU/H)	OUTLINE DIMENSION				AIR OUTLET OPENING SIZE		AIR RETURN OPENING SIZE		MOUNTED LUG SIZE	
	A	B	C	D	E	F	G	H	I	J
06K & 09K/12K	27.6/700	7.9/200	19.9/506	17.7/450	6.0/152	21.1/537	7.3/186	23.6/599	29.2/741	14.2/360
18K	34.6/880	8.3/210	26.5/674	23.6/600	5.4/136	27.8/706	7.5/190	30.8/782	36.2/920	20.0/508

Table 13 — High Static Dimensions

SYSTEM SIZE		12K	18K	24K	36K	48K	60K
		(208/230 V)	(208/230 V)	(208/230 V)	(208/230 V)	(208/230 V)	(208/230 V)
Height (H)	in (mm)	9.65(245)	9.65(245)	9.65(245)	11.81(300)	11.81(300)	14.96(380)
Width (W)	in (mm)	27.56(700)	39.37(1000)	39.37(1000)	47.24(1200)	47.24(1200)	55.12(1400)
Depth (D)	in (mm)	29.53(750)	29.53(750)	29.53(750)	29.53(750)	29.53(750)	31.50(800)
Weight - Net	lbs. (kg)	64.15(29.1)	79.81(36.2)	80.47(36.5)	106.26(48.2)	111.33(50.5)	161.38(73.2)
PACKAGING							
Height	in (mm)	11.73(298)	11.97(304)	11.97(304)	14.13(359)	14.13(359)	17.52(445)
Width	in (mm)	36.42(925)	48.23(1225)	48.23(1225)	56.10(1425)	56.10(1425)	62.99(1600)
Depth	in (mm)	33.46(850)	33.86(860)	33.86(860)	33.86(860)	33.86(860)	36.02(915)
Weight - Gross	lbs. (kg)	73.85(33.5)	91.27(41.4)	91.93(41.7)	120.37(54.6)	124.78(56.6)	178.13(80.8)
Carton Drawing No.	--	ZXW-910*835* 270S-NS1	ZXW-1210*845* 280S-NS1	ZXW-1210*845* 280S-NS1	ZXW-1410*845* 335S-NS1	ZXW-1410*845* 335S-NS1	ZXW-1585*900* 420S-NS1
Carton Material	--	Double corrugated cardboard					
Material Thickness	in (mm)	0.295(7.5)	0.295(7.5)	0.295(7.5)	0.295(7.5)	0.295(7.5)	0.295(7.5)

Installation Guidelines

Wood

Different ceiling types call for different mount applications. Place the wood mounting across the roof beam, then install the hanging screw bolts.

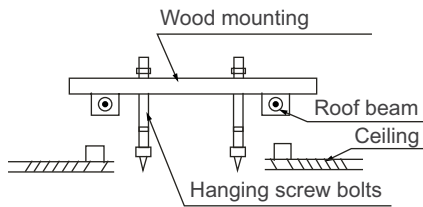

Fig. 14 —Wood Mounting

New Construction

Inlay or embed the screw bolts.



Fig. 15 —New Concrete Bricks

Existing Construction

Use an embedding screw bolt, crock, and stick harness.

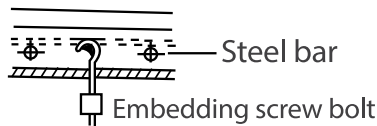

(Pipe hanging and embedding screw bolt)

Fig. 16 —Original Concrete Bricks

Steel Roof Beam Structure

1. Install and use the supporting steel angle.

NOTE: The unit body must be completely aligned with the hole. Ensure that the unit and the hole are the same size before moving on.

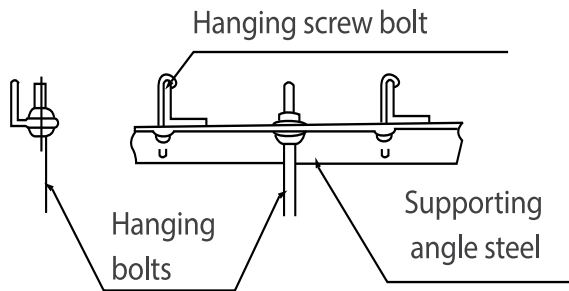

Fig. 17 —Steel Roof Beam

2. Install and fit pipes and wires after you have finished installing the main body. When choosing where to start, determine the direction of the pipes to be drawn out. Especially in cases where there is a ceiling involved, align the refrigerant pipes, drain pipes, and indoor and outdoor lines with their connection points before mounting the unit.
3. Install hanging screw bolts.
4. After you select an installation location, align the refrigerant pipes, drain pipes, as well as indoor and outdoor wires with their connection points before mounting the unit.
5. Drill 4 holes 4in (10cm) deep at the ceiling hook positions in the internal ceiling. Hold the drill at a 90° angle to the ceiling.
6. Secure the bolt using the washers and nuts provided.
7. Install the four suspension bolts.
8. Mount the indoor unit with at least two people to lift and secure it. Insert suspension bolts into the unit's hanging holes. Fasten them using the washers and nuts provided.

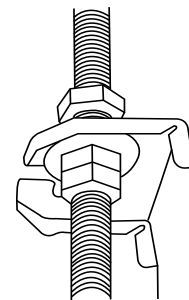

Fig. 18 —Secure Suspension Bolts

9. Position the indoor unit flat, using a level indicator to prevent leaks.

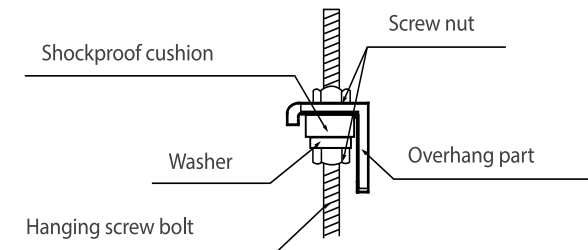

Fig. 19 —Position the Unit Flat

NOTE: Confirm that the minimum drain tilt is 1/100 or more.

Step 4: Duct and Accessories Installation

1. Install the filter according to the size of the air inlet.
2. Install the canvas tie-in between the body and duct.

NOTE: The air inlet and air outlet duct should be far enough apart enough to a avoid air passage short-circuit.

3. Connect the duct according to the following diagram:
 - Ceiling-mounted

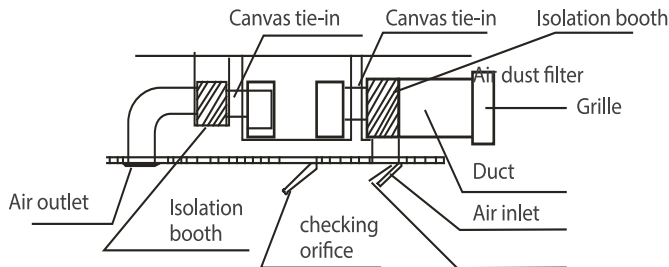

Fig. 20 —Connect the Duct

NOTE: Confirm the minimum drain tilt is 1/100 or more.

1. The min. length of the duct should be more than 3.28ft/1m, and fix on the air inlet by screws (applicable to the unit that the air inlet filter is not fasten by screws).
2. The inlet of the air duct needs to be installed with a grille, which needs to be fixed to the air duct with screws.
3. Do not place the connecting duct weight on the indoor unit.
4. When connecting the duct, use an nonflammable canvas tie-in to prevent vibrating.
5. Insulation foam must be wrapped outside the duct to avoid condensate. An internal duct under layer can be added to reduce noise, if the end-user requires.

Step 5: Filter Installation

1. Take off the ventilation panel and flange.

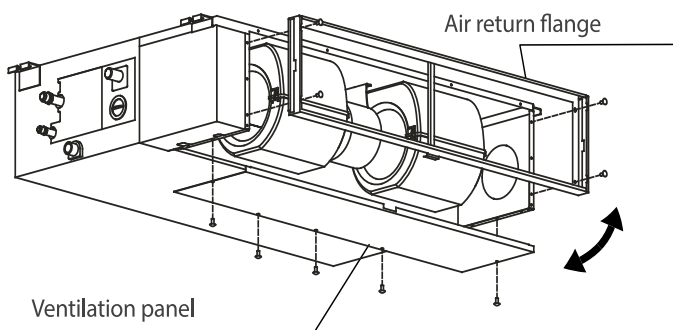

Fig. 21 —Remove Ventilation Panel

2. Bend the rear ventilation panel 90 degrees along the dotted line into a descending ventilation panel.
3. Change the mounting positions of the ventilation panel and air return flange.
4. When installing the filter mesh, fit it into the flange as illustrated in the following figure.

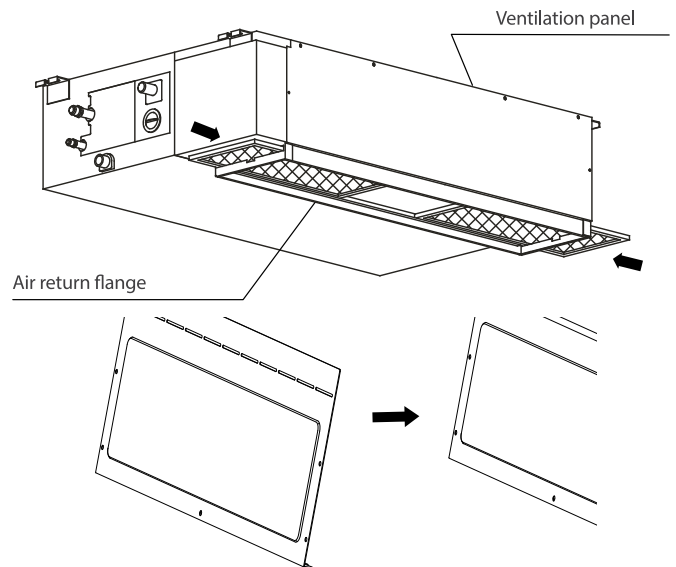

Fig. 22 —Install Filter Mesh

Or

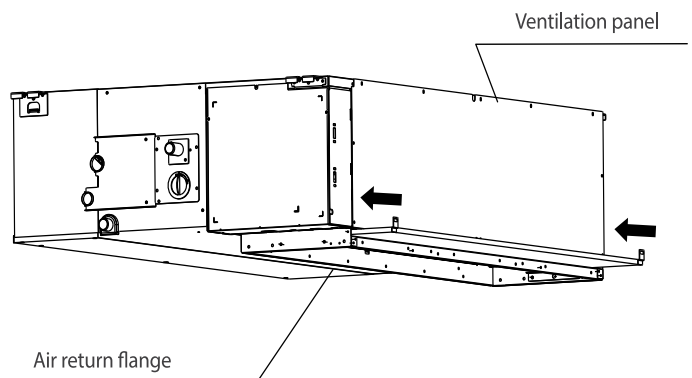

Fig. 23 —Install Filter Mesh (Alternate)

NOTE: All the figures in this manual are for demonstration purposes only. The air conditioner you have purchased may be slightly different in design, though similar in shape.

Step 6: Motor and Drain Pump Maintenance

Motor Maintenance

1. Remove the ventilated panel.
2. Remove the blower housing.
3. Remove the motor.

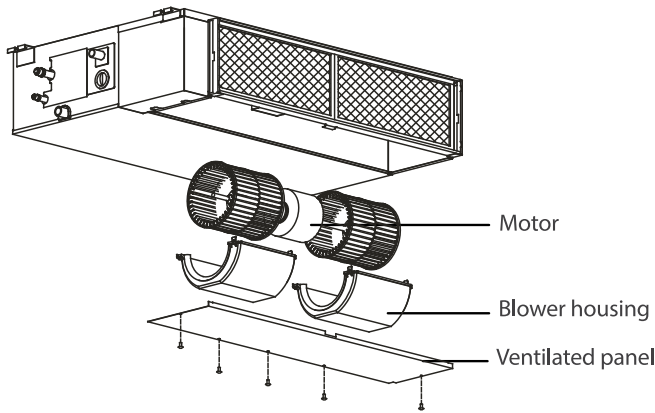

Fig. 24 —Motor Maintenance

Pump Maintenance

1. Remove four screws from the drain pump.
2. Unplug the pump power supply and water level switch cable.
3. Detach the pump.

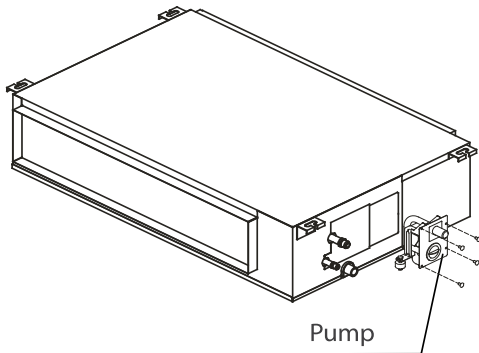

Fig. 25 —Pump Maintenance

B. DRAIN CONNECT

Step 1. Drill Wall Hole for Connective Piping

1. Determine the location of the wall hole based on the location of the outdoor unit.
2. Using a 2.5in (65mm) or 3.54in (90mm) core drill, drill a hole in the wall. Make sure that the hole is drilled at a slight downward angle, so that the outdoor end of the hole is lower than the indoor end by about 0.5in (12mm). This will ensure proper water drainage.
3. Place the protective wall cuff in the hole. This protects the edges of the hole and will help seal it when you finish the installation process.

! CAUTION

Property Damage Hazard
When drilling the wall hole, make sure to avoid wires, plumbing, and other sensitive components.

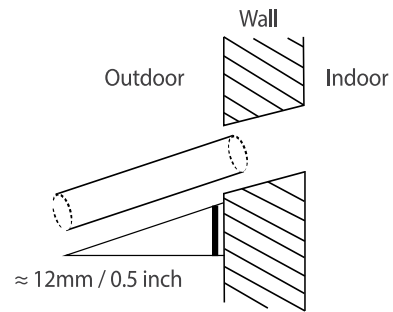

Fig. 26 —Drill Wall Hole

Step 2: Connect Drain Hose

The drainpipe is used to drain water away from the unit. Improper installation may cause unit and property damage.

! CAUTION

Insulate all piping to prevent condensation, which could lead to water damage.
If the drainpipe is bent or installed incorrectly, water may leak and cause a water-level switch malfunction.
In **HEAT** mode, the outdoor unit will discharge water. Ensure that the drain hose is placed in an appropriate area to avoid water damage and slippage.
DO NOT pull the drainpipe forcefully. This could disconnect it.

Note on Purchasing Pipes

Installation requires a polyethylene tube (exterior diameter = 1.46-1.54in/3.7-3.9cm; interior diameter = 1.26in/3.2cm), which can be obtained at your local hardware store or dealer.

Indoor Drainpipe Installation

Install the drainpipe as illustrated in the following Figure.

1. Cover the drainpipe with heat insulation to prevent condensation and leakage.
2. Attach the mouth of the drain hose to the unit's outlet pipe. Sheath the mouth of the hose and clip it firmly with a pipe clasp.

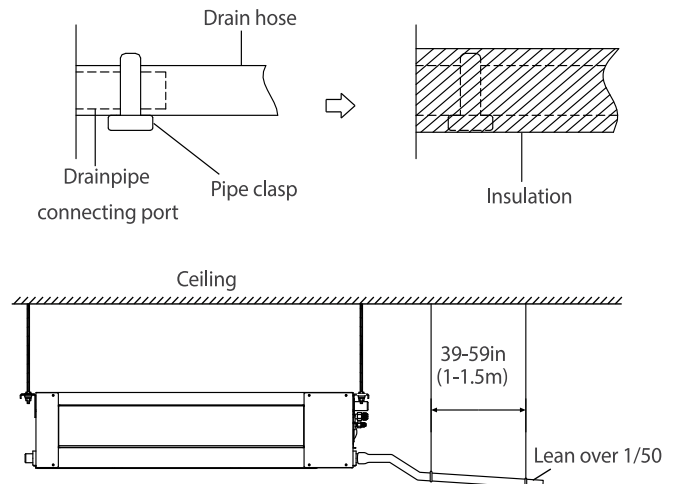

Fig. 27 —Drainpipe Installation

ADDITIONAL DRAINAGE INSTRUCTIONS

Indoor Unit Dimensions

If the unit's dimensions match the contents in the diagram, follow these instructions.

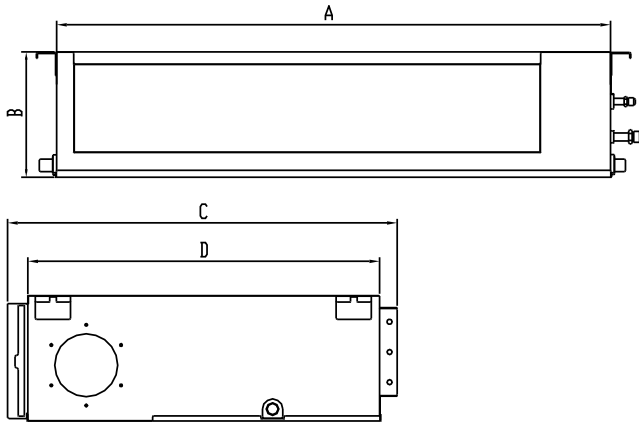

Fig. 28 —Indoor Unit Dimensions

Table 14 — Dimensions Per Model

MODEL	OUTLINE DIMENSIONS (INCH/MM)			
	A	B	C	D
A	27.6/700	7.9/200	19.9/506	17.7/450
B	34.6/880	8.3/210	26.5/674	23.6/600

Model A

Horizontal Installation

With external pump:

Cut both ends of the rubber hose into a straight shape, use it to connect the drain (Connector A) and the external pump and secure it with clamps on both ends. Then connect the drainpipe to the Connector B (see Fig. 29).

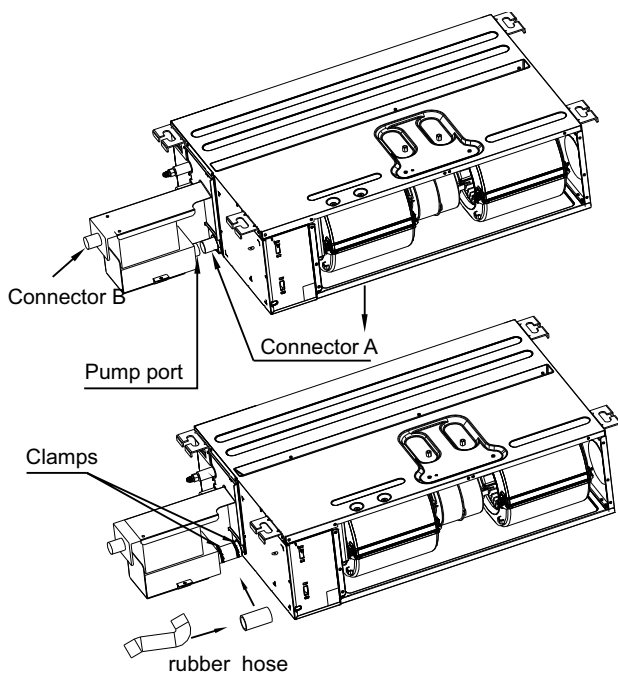

Fig. 29 —Connect the Drain

Vertical Installation

Disable the pump:

The pump must be **disabled** while the unit is installed vertically or the pump assembly is removed from its original position. Open the cover of E-Parts Box assembly, unplug the “PUMP” pin to disable the pump function, and short connect “CN5” plug to disable the water level sensor (see Fig. 30).

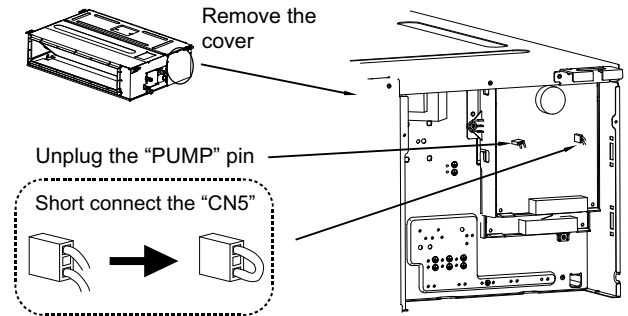

Fig. 30 —Remove the Cover and Unplug the pin

Drain pipe connecting:

When installed vertically (up flow), the pump must first be disabled (review “Disable the pump:” on page 23). For the unit with an external pump, the whole pump assembly can be removed. Then connect the drainpipe to the drain connector (see Fig.31).

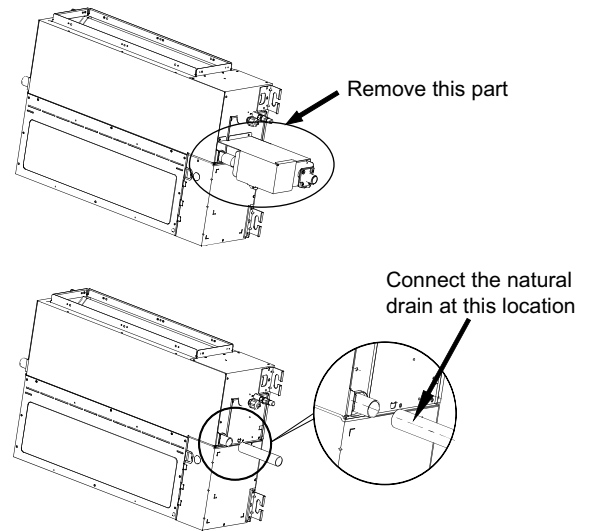

Fig. 31 —Drain Pipe Connecting

Model B

Horizontal Installation

With External Pump:

Drain connector A, B and C are initially covered with caps. Remove the cap on drain connector B, connect the external pump to drain connector B using a hose and two hose clamps. Then connect the drainpipe to connector D (see Fig. 32). Plug the external pump to the “PUMP” pin and the water level sensor to the “CN5” to enable the pump (see Fig.33).

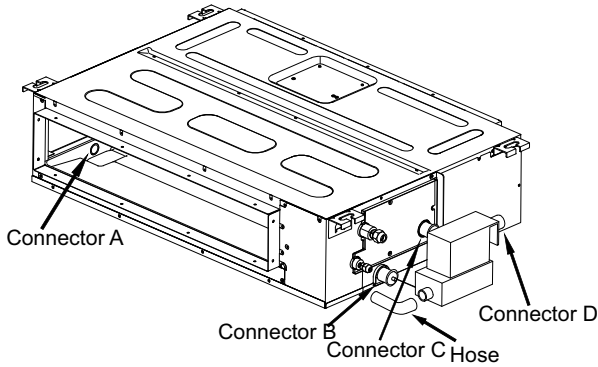

Fig. 32 —Connect the drain pipe

Vertical Installation

Disable the Pump:

The pump must be disabled while the unit is installed vertically or the pump assembly is removed from its original position. Open the cover of E-Parts Box assembly, unplug the “PUMP” pin to disable the pump function, and short connect the “CN5” plug to disable the water level sensor (see Fig. 33).

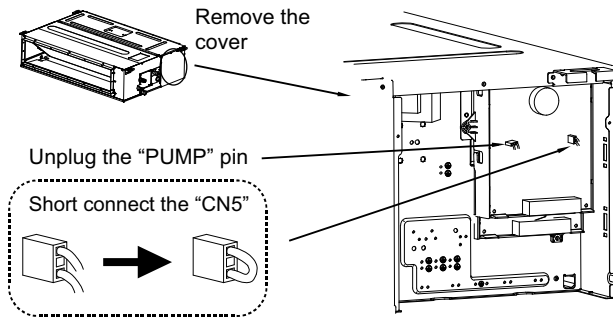

Fig. 33 —Disable pump

Drain Pipe Connecting:

When installed vertically (up flow), the pump must be first disabled. (review “Disable the Pump:” on page 24). For the unit with an external pump, the whole pump assembly can be removed. Then take the cap on drain connector off and connect the drainpipe to drain connector (see Fig. 34, Fig.35 and Fig.36).

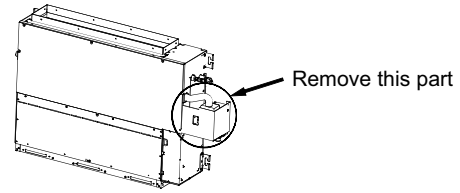

Fig. 34 —Remove the pump assembly

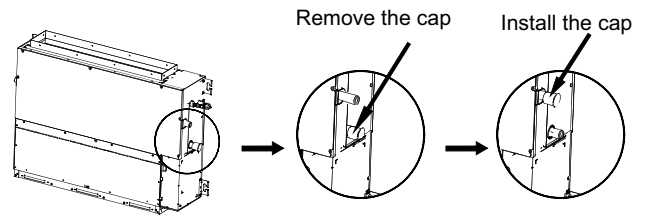

Fig. 35 —Remove the cap

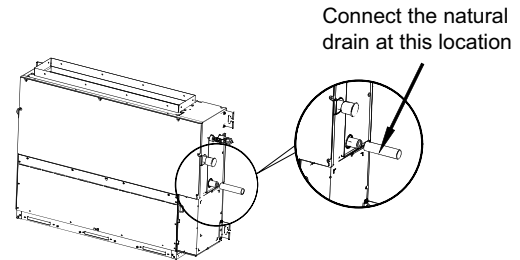

Fig. 36 —Connect the drain

C. CONDENSATE DRAIN INSTALLATION

The condensate pipe is used to drain water away from the unit. Improper installation may cause unit and property damage. The unit is supplied with a drain adapter allowing the use of a field supplied 3/4 in. PVC Schedule 40 drain pipe. When installing the condensate piping, keep in mind the following details and follow these recommendations:

NOTE: When installing drains, adhere to the local sanitation codes.

- The ducted slim indoor unit is supplied with a condensate lift pump that is capable of lifting water 29.5in. (750mm).
- Ensure the highest point in the condensate piping is as close to the unit as possible (see Fig. 39).
- Ensure the condensate piping slopes downward in the direction of the condensate flow, with a minimum gradient of 1/100.
- When multiple units are connected to a common condensate drain, ensure the drain is large enough to accommodate the volume of condensate from all the units. Consider the recommendation to install an air vent in the condensate piping to prevent air lock.
- Do not install condensate piping where exposure to freezing temperatures is possible.
- To prevent the pipe from sagging, hangers should be spaced every 36 in (91.44cm). Be sure to follow local codes.
- If the drainpipe outlet is higher than the body's pump joint, provide a lift pipe for the indoor unit's exhaust outlet.
- Do not install the lift pipe higher than 21 in. (55cm) from the center line of the pump outlet pipe. The distance between the unit and the lift pipe must be less than 8 in (20cm). An incorrect installation could allow water to flow back into the unit and flood.
- To prevent air bubbles, keep the drain hose horizontal or slightly upward. See letter (A) Figure 39.

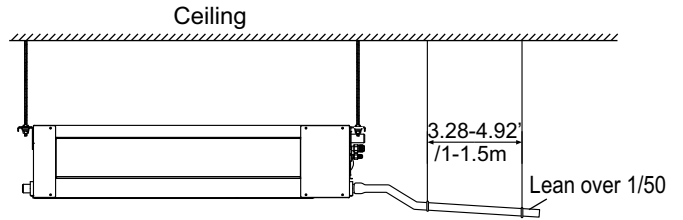

Fig. 38 —Condensate piping without a pump

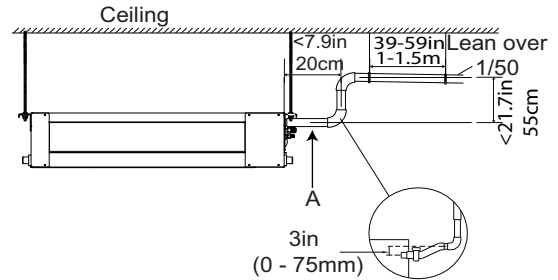

Fig. 39 —Condensate piping with a pump

When connecting multiple drainpipes, install the pipes as shown in Fig. 40.

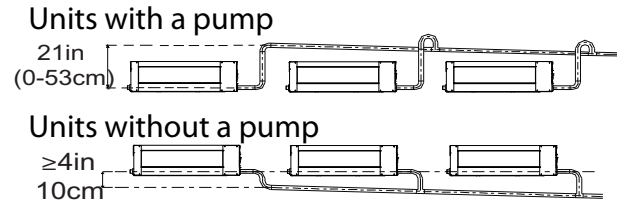

Fig. 40 —Connecting Multiple Drain Pipes

3. Pass the drain hose through the wall hole. Ensure the water drains to a safe location where it will not cause water damage or a slipping hazard.

NOTE: The drainpipe outlet should be at least 2in (5cm) above the ground. If the outlet touches the ground, the unit may become blocked and malfunction. If you discharge the water directly into a sewer, make sure the drain has a U or S pipe to catch odors that might otherwise come back into the house.

CAUTION

Insulate all piping to prevent condensation, which could lead to water damage.

If the drainpipe is bent or installed incorrectly, water may leak and cause a water-level switch malfunction.

In **HEAT** mode, the outdoor unit discharges water. Ensure that the drain hose is placed in an appropriate area to avoid water damage and slippage.

DO NOT pull the drainpipe forcefully. This could disconnect it.

1. Cover the drain hose with heat insulation to prevent condensation and leakage.
2. Attach the mouth of the drain hose to the unit's outlet pipe. Sheath the mouth of the hose and clip it firmly with a pipe clasp (see Fig. 37).

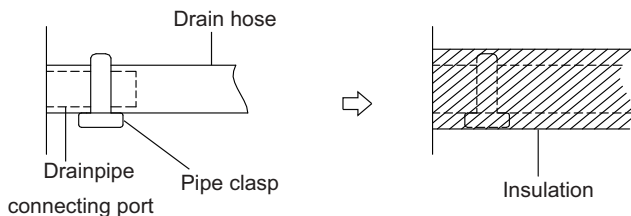

Fig. 37 —Indoor Drainpipe Installation

CONDENSATE DRAIN AND CONDENSATE LIFT PUMP INSTALLATION (HORIZONTAL INSTALLATION)

For sizes 9, 12 and 18, the condensate lift pump is provided in a separate box. Use the following steps to install the External Condensate Lift Pump for a horizontal installation of the indoor unit.

NOTE: Drain connections A, B and C are covered with caps.

1. For sizes 09K and 12K:

- a. Remove the cap on the drainage outlet.
- b. Cut both ends of the rubber tubing provided into a straight one.
- c. Connect the drainage outlet and condensate lift pump using the rubber tubing and secure it with clamps on both ends (see Fig. 41).
- d. Plug the power cable of the external pump to CN13 / "PUMP" pin and plug the water level sensor cable to the CN5 / "WATER" to enable the pump (see Fig. 45).

2. For size 18K:

- a. Remove the cap on drain connector B.
- b. Connect drain connector B and the condensate lift pump using the L rubber hose and secure it with clamps on both ends.
- c. Connect the drainpipe to connector D (see Fig. 42).
- d. Plug the power cable of the external pump to CN13 / "PUMP" pin and plug the water level sensor cable to CN5 / "WATER" to enable the pump (see Fig. 43).

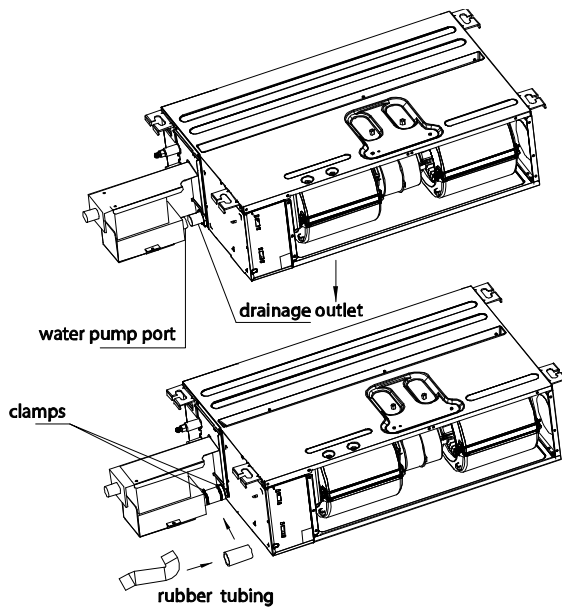

Fig. 41 —Condensate lift pump installation sizes 09K-12K

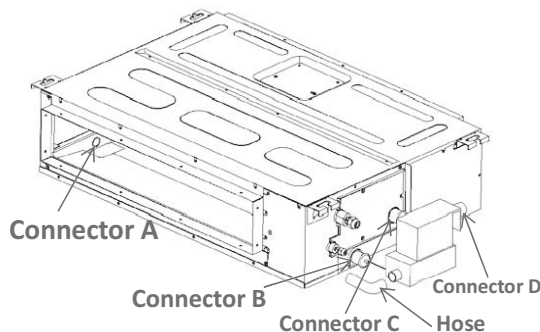

Fig. 42 —Condensate lift pump installation size 18K

3. Sizes 24K, 36K, 48K and 58K have a built-in condensate lift pump. Drain connections (A, B and C) are covered with caps. Connect the drainpipe to connector D (see Fig. 43).

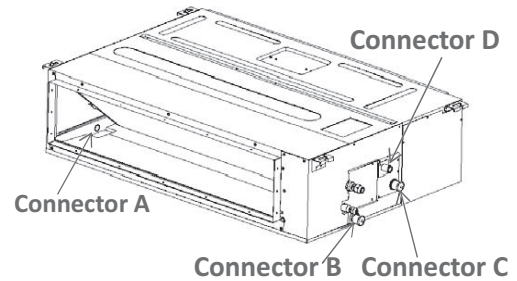

Fig. 43 —Connection of drain pipe to condensate lift pump sizes 24-58K
Disabling the Condensate Lift Pump

The pump must be disabled while the unit is installed vertically (upflow) or the lift pump assembly is removed from its original position:

- Open the Control Box assembly cover, unplug the "CN13 PUMP" pin to disable the pump function, and short-connect the "CN5 WATER" plug to disable the water level sensor by either splicing the wires coming out of the CN5 WATER plug or by using a jumper plug Replacement Component part number 17401204000333 (optional in some units otherwise sold separately) (see Figures 44 and 45).

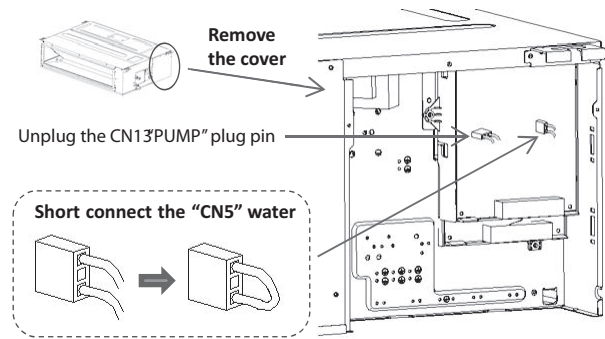

Fig. 44 —Disable condensate lift pump

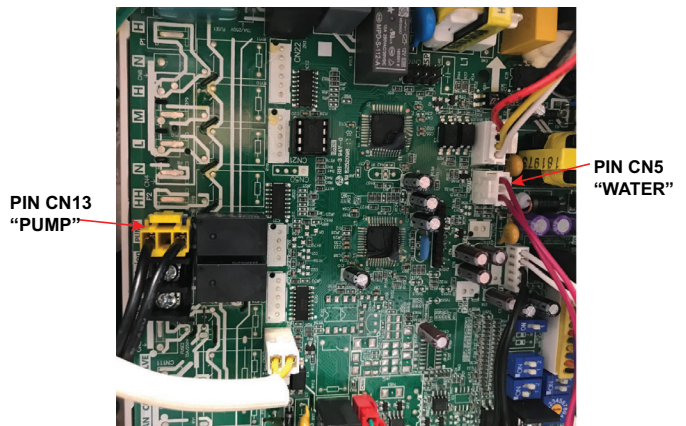

Fig. 45 —Condensate Lift Pump Connectors

Remove the cap from connector C and connect the condensate drain pipe to drain connector C (see Fig. 51).

NOTE: For size 18K, the external condensate lift pump should be removed (see Fig. 47).

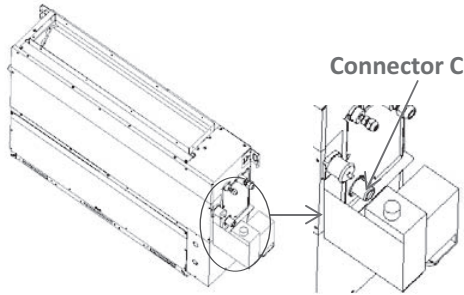

Fig. 46 —Sizes 09K/12K, 18K with External Condensate Lift Pump

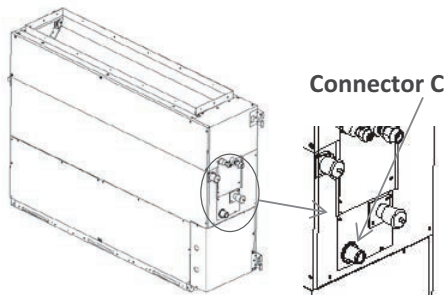

Fig. 47 —Sizes 24K to 48K with Built-in Condensate Lift Pump

DRAINAGE TEST FOR UNITS WITHOUT A CONDENSATE LIFT PUMP

1. Ensure the drainpipe is unobstructed.
2. Fill the drain pan with 0.5 gallons (2 liters) of water.

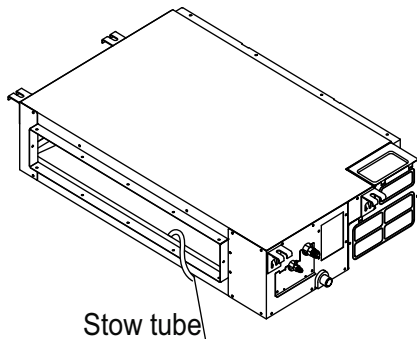

Fig. 48 —Units without a pipe

CONDENSATE LIFT PUMP AND DRAINAGE TEST

Follow these steps to perform the test:

1. Remove the test cover by rotating it counter-clockwise (see Fig. 49).
2. Using a piece of tubing or pipe to fill the condensate lift pump reservoir with 70 oz. of water (see Fig. 50).
3. Turn the unit **ON** in the **COOLING** mode and the condensate lift pump turns on. Watch the end of the drain pipe for any water.

NOTE: It may take some time for the water to travel, depending on the length of the drain pipe.

4. During this test, check all bends or joints for leakage.

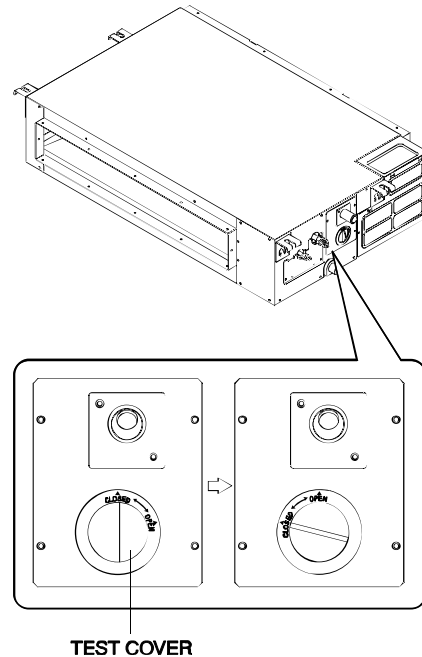

Fig. 49 —Check the Bends and Joints for Leakage

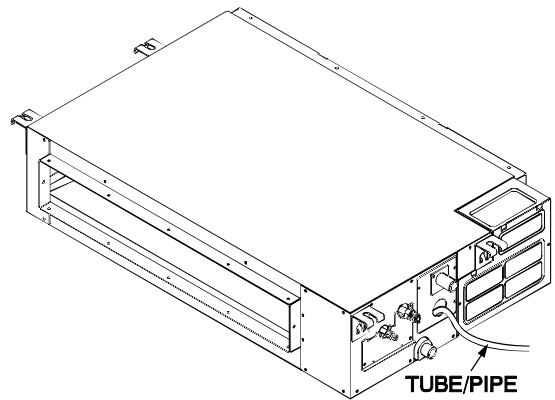

Fig. 50 —Tube Pipe Insert

Condensate Lift Pump Maintenance

1. Remove the four screws from the drain pump (sizes 24K to 48K).
2. Unplug the pump power supply and the water level switch cable.
3. Detach the pump.

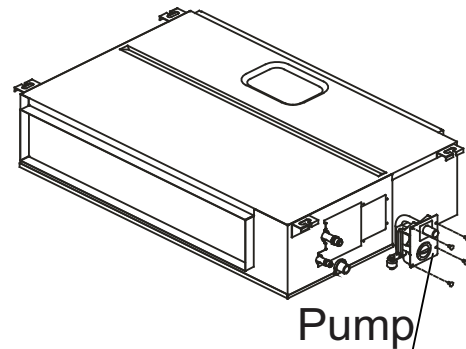

Fig. 51 —Detach the pump

Notes on Drainpipe Installation

- When using an extended drainpipe, tighten the indoor connection with an additional protection tube. This prevents it from pulling loose.
- The drainpipe should slope downward at a gradient of at least 1/100 to prevent water from flowing back into the air conditioner.
- To prevent the pipe from sagging, space hanging wires every 39-59 in (1-1.5 m).
- If the outlet of the drainpipe is higher than the body's pump joint, use a lift pipe for the indoor unit's exhaust outlet. The lift pipe must be installed no higher than 21.7 in (55 cm) from the ceiling board. The distance between the unit and the lift pipe must be less than 7.9 in (20 cm). The distance between the unit and the lift pipe must be less than 7.9 in (20 cm). Incorrect installation could cause water to flow back into the unit and flood.
- To prevent air bubbles, keep the drain hose level or slightly tiled up (< 3 in/75 mm).

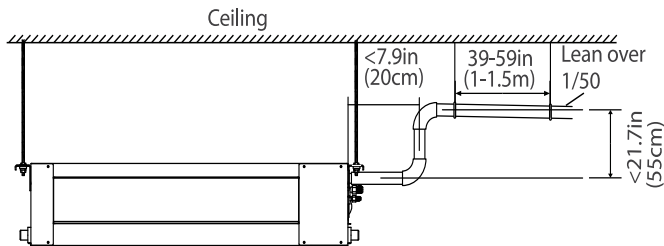

Fig. 52 —Drainpipe for Units with a Pump

NOTE: When connecting multiple drainpipes, install the pipes as illustrated.

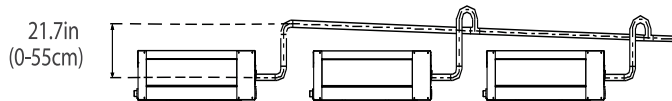

Fig. 53 —Units with a Pump

4. Pass the drain hose through the wall hole. Ensure the water drains to a safe location where it will not cause water damage or a slipping hazard.

NOTE: The drainpipe outlet should be at least 1.9 in (5 cm) above the ground. If it touches the ground, the unit may become blocked and malfunction. If you discharge the water directly into a sewer, make sure that the drain has a U or S pipe to catch odors that might otherwise come back into the house.

Drainage Test

Check whether the drainpipe is unimpeded. This test should be performed on newly built houses before the ceiling is installed.

Units with a Pump

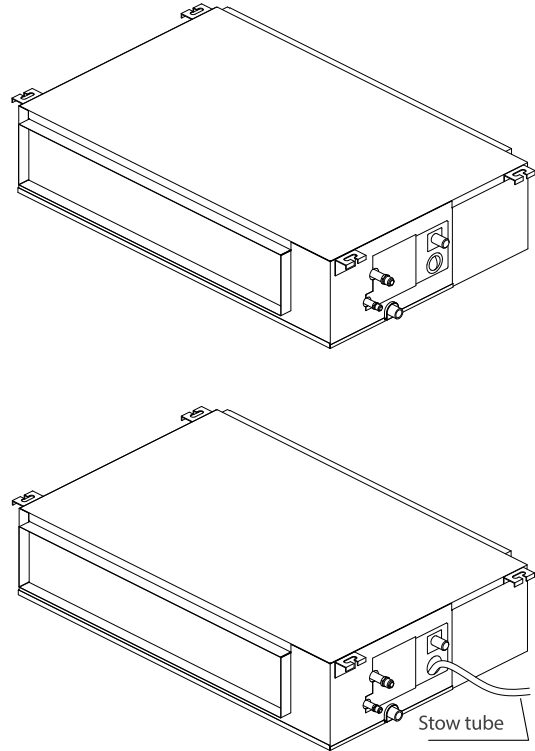

Fig. 54 —Drainage Test

1. Remove the test cover.
2. Fill the water pan with 2 liters of water.
3. Turn on the unit in **COOLING** mode. You will hear the drain pump. Check whether the water is discharged properly (a 1-minute lag is possible, depending on the length of the drain pipe). Check whether water leaks from the joints.
4. Turn off the air conditioner and put the cap back on.

D. CONNECT THE REFRIGERANT PIPES

REFRIGERANT PIPING CONNECTION

When connecting refrigerant piping, **DO NOT** let substances or gases other than the specified refrigerant enter the unit. The presence of other gases or substances will lower the unit’s capacity, and can cause abnormally high pressure in the refrigeration cycle. This can cause explosion and injury.

Notes on Pipe Length and Elevation

Table 15 — Maximum Length and Drop Height Based on Models (Low Static)

MODEL	LENGTH OF PIPING	MAXIMUM DROP HEIGHT
06K & 09K/12K	82 ft/25 m	49.2 ft/15 m
18K	98.4 ft/30 m	65.6 ft/ 20 m

Table 16 — Maximum Length and Drop Height Based on Models (High Static)

MODEL	LENGTH OF PIPING	MAXIMUM DROP HEIGHT
9K/12K	82ft/25m	49.2ft/15m
18K	98.4ft/30m	65.6ft/20m
24K	164ft/50m	82ft/25m
36K/48K/60K	246ft/75m	98.4ft/30m

Ensure that the length of the refrigerant pipe, the number of bends, and the drop height between the indoor and outdoor units meets the requirements shown in the table next to it.

CAUTION

UNIT DAMAGE HAZARD

The branching pipe must be installed horizontally. An angle of more than 10° may cause malfunction.

DO NOT install the connecting pipe until both indoor and outdoor units have been installed.

Insulate both the gas and liquid piping to prevent condensation.

Step 1: Cut Pipes

When preparing refrigerant pipes, take extra care to cut and flare them properly. This will ensure efficient operation and minimize the need for future maintenance.

- Measure the distance between the indoor and outdoor units.
- Using a pipe cutter, cut the pipe a little longer than the measured distance.
- Ensure that the pipe is cut at a perfect 90° angle.

IMPORTANT: Do not deform the pipe while cutting. Be extra careful not to damage, dent, or deform the pipe while cutting. This will drastically reduce the heating.

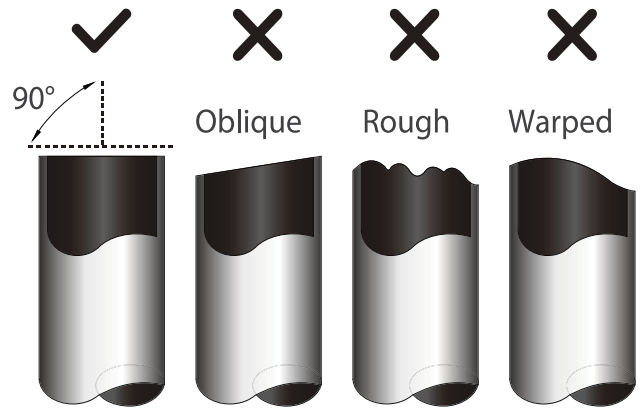

Fig. 55 —Correct and Incorrect Pipe Cutting

Step 2: Remove Burrs

Burrs can affect the air-tight seal of refrigerant piping connection. They must be completely removed.

- Hold the pipe at a downward angle to prevent burrs from falling into the pipe.
- Using a reamer or deburring tool, remove all burrs from the cut section of the pipe.

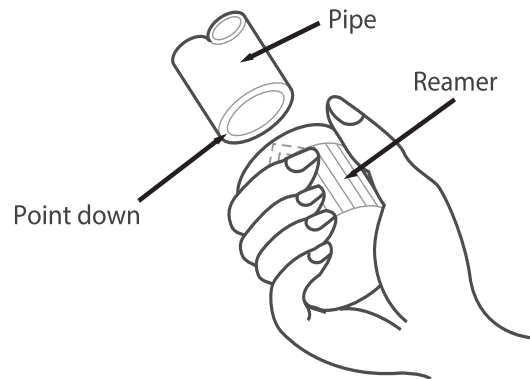

Fig. 56 —Remove Burrs

Step 3: Flare Pipe Ends

Proper flaring is essential to achieve an airtight seal.

- After removing burrs from cut pipe, seal the ends with PVC tape to prevent foreign materials from entering the pipe.
- Sheath the pipe with insulating material.
- Place flare nuts on both ends of pipe. Make sure they are facing in the right direction, because you can not put them on or change their direction after flaring.

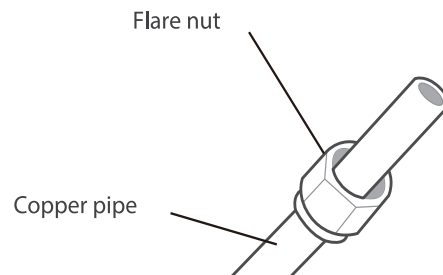

Fig. 57 —Flare Nut

- Remove PVC tape from ends of pipe when ready to perform flaring work.
- Clamp flare form on the end of the pipe. The end of the pipe must extend beyond the flare form.

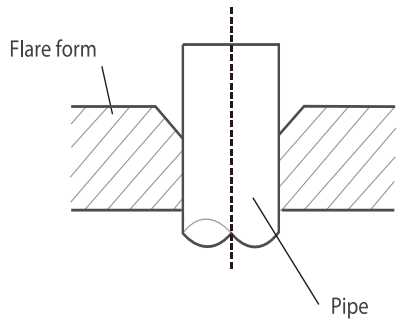

Fig. 58 —Flare Form

- Place flaring tool onto the form.
- Turn the handle of the flaring tool clockwise until the pipe is fully flared.

Table 17 — Piping Extension Beyond Flare Form

PIPE GAUGE	TIGHTENING TORQUE	FLARE DIMENSIONS (A)	FLARE SHAPE
Ø1/4in (Ø6.35mm)	18-20 N.m (180-200kgf.cm)	0.33~0.34in (8.4~8.7mm)	
Ø3/8in (Ø9.52mm)	32-39 N.m (320-390kgf.cm)	0.52~0.53in (13.2~13.5mm)	
Ø1/2in (Ø12.7mm)	49-59 N.m (490-590kgf.cm)	0.64~0.65in (16.2~16.5mm)	

- Remove the flaring tool and flare form, then inspect the end of the pipe for cracks and even flaring.

Step 4: Connect Pipes

Connect the copper pipes to the indoor unit first, then connect it to the outdoor unit. You should first connect the low-pressure pipe, then the high pressure pipe.

- When connecting the flare nuts, apply a thin coat of refrigeration oil to the flared ends of the pipes.
- Align the center of the two pipes that you will connect.
- Tighten the flare nut snugly by hand. Using a wrench, grip the nut on the unit tubing.
- While firmly gripping the nut, use a torque wrench to tighten the flare nut according to the torque values in the above table.

NOTE: Use both a spanner and torque wrench when connecting or disconnecting pipes to/from the unit.

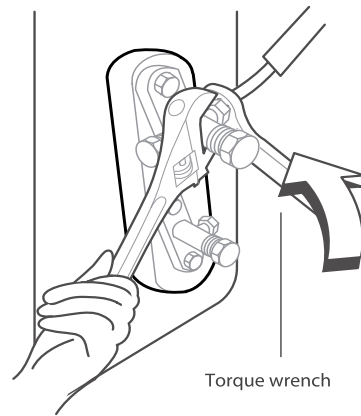

Fig. 59 —Torque Pipe Connections

! CAUTION

Ensure to wrap insulation around the piping. Direct contact with the bare piping may result in burns or frostbite.

Make sure the pipe is properly connected. Over tightening may damage the bell mouth and under tightening may lead to leakage.

NOTE: MINIMUM BEND RADIUS. Carefully bend the tubing in the middle according to the diagram below. DO NOT bend the tubing more than 90° or more than 3 times.

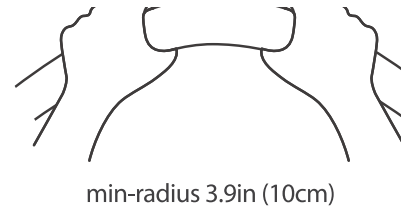

Fig. 60 —Use Care When Bending

- After connecting the copper pipes to the indoor unit, wrap the power cable, signal cable and the piping together with binding tape.

NOTE: DO NOT intertwine signal cable with other wires while bundling these items together. Do not intertwine or cross the signal cable with any other wiring.

WIRELESS REMOTE CONTROLLER INSTALLATION

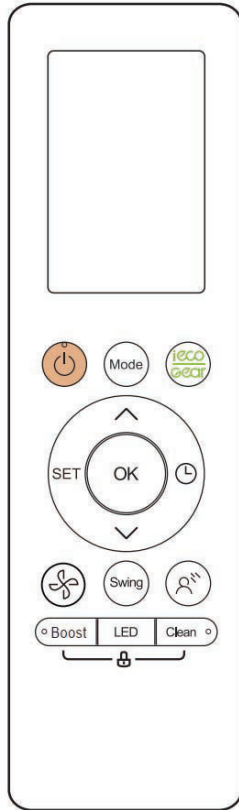

Fig. 61 — Wireless Remote Controller (RG10R(2S))

To attach the mounting bracket:

1. Use the two screws supplied with the wireless remote control to attach the mounting bracket to the wall in a location selected by the customer and within operating range.
2. Install the batteries in the remote control.
3. Place the remote control into the remote control mounting bracket.
4. For remote controller operation, refer to the unit's owner manual.

NOTE: If a wireless remote controller is used, relocate the IR receiver within the line of sight of the remote location using the 6 ft. cable included. The factory location of the IR receiver is inside the remote controller box (see Fig. 62).

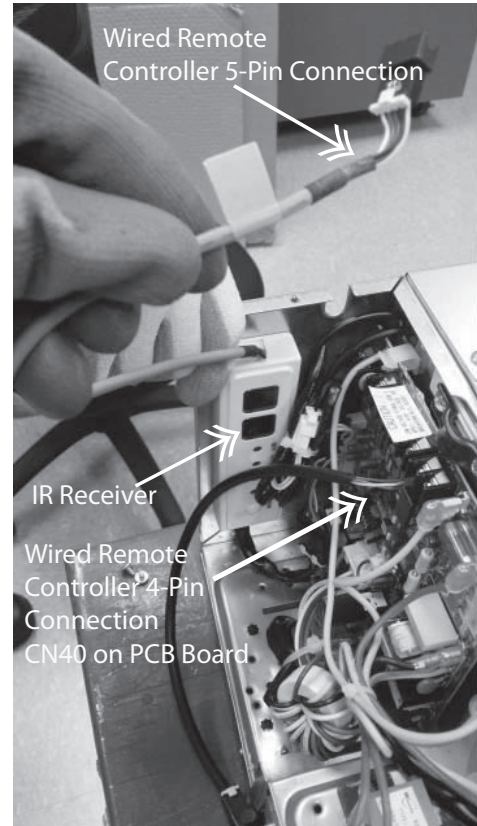

Fig. 62 —Control Box

NOTE: For remote control operation, refer to the remote control's owners manual.

WIRED REMOTE CONTROLLER INSTALLATION

To connect the included wired remote controller (7 Day Programmable **KSACN1401AAA**) to the indoor unit, the 4-pin adapter cable supplied with the controller and plug it into CN40 located on the control board.

To connect the wired remote controller (**Timer Function KSACN1401AAA sold separately**) to the indoor unit, use a 5-core shielded cable supplied with the wired controller to plug into the 5-pin connector from the IR receiver located in the control box (see figure 62).

For setup instructions, refer to the wired remote controller installation manual.

IR Receiver Display Panel

1. Press **MANUAL** on the IR Receiver Display Panel located in the control box to begin testing.

NOTE: A protection feature prevents the system from starting for approximately 3 to 4 minutes.

2. Push **MODE**, select **COOLING**, **HEATING**, and **FAN** mode to verify that all the functions work as designed.
3. To run the test using the **MANUAL** option on the indoor unit:
 - a. Open the front panel of the indoor unit;
 - b. Press **MANUAL** once to energize the unit.

The set conditions of the manual operation are as follows:

- Preset the set point: 76°F (24°C)
- Fan speed: **AUTO**
- Discharge the air direction: Pre-set position based on an operation in the **COOL** or **HEAT** mode.

NOTE: Set the MANUAL option to OFF (by pushing it twice again) after completing the test.

OPTIONAL WIRED WALL-MOUNTED REMOTE CONTROL INSTALLATION

The wired remote controller comes with the following items:

- A set of installation instructions and owner's manuals
- 3 M4X20 Screws to mount on the wall
- 4 wall plugs to mount on the wall
- 2 M4X25 to mount on switch box
- 2 plastic screw bars to fix on switch box
- 1 set of batteries
- 1 set of connecting wires to connect to indoor unit's main board



Fig. 63 — Wired Controller

For wired controller set up and installation instructions, consult the wired controller installation manual.

NOTE: The indoor ducted units can be programmed for different static pressures or Real-time constant airflows, use the following steps to set the static pressure or Real-time constant airflow.

USING THE 120L WIRED CONTROLLER

To set Static Pressure Airflow

The factory default setting is SP1, The external static pressure can be manually changed to the fan curves 1,2,3,4,5,6,7,8.

- Press and hold **ON/OFF** and **FAN** for approximately 7 seconds.
- Press “^” or “v” to scroll through the menu and select **8**.
- Press and hold **ON/OFF** for approximately 2 seconds, Press “^” or “v” to scroll through and select 1-8.
- Press the check mark or **OK** and the display board displays **CS**.
- Press and hold **ON/OFF** and **FAN** for approximately 7 seconds, Then exit test mode.

To set Static Pressure Airflow

Use the Automatic Airflow “AF” Adjustment function to realize Real-time constant airflows.

- Press and hold **ON/OFF** and **FAN** for approximately 7 seconds.
- Press “^” or “v” to scroll through the menu and select “8”.
- Press and hold **ON/OFF** for approximately 2 seconds. Press “^” or “v” to scroll through and select “AF”.
- Press check mark or “**OK**” and the display board displays “CS”.
- Press and hold **ON/OFF** and **FAN** for approximately 7 seconds, Then exit test mode.

NOTE: Before commissioning, check the power connection of the machine, turn on the power, and keep the machine not working.

NOTE: If there is no change after airflow adjustment, perform the setting again.

NOTE: Low static pressure series 06K,09K,12K,18K models, SP options can only be 1-4.

WHEN USING THE 120N WIRED CONTROLLER

To Set Static Pressure Air Flow

The factory default setting is SP1, The external static pressure can be manually changed to the fan curves 1,2,3,4,5,6,7,8.

- Press and hold **Copy** for approximately 3 seconds. The lower right corner displays **P:00**, Press **OK**.
- Press “^” to scroll through the menu. The lower right corner shows **SP**, Press **OK**.
- Press “^” or “v” to scroll through the menu and select 1-8, Press **OK**.
- Press “**Back**” to exit the test mode.

To Set Real-Time Constant Air Flow

Use the Automatic Airflow “AF” Adjustment function to realize Real-time constant airflows.

- Press and hold **Copy** for approximately 3 seconds. The lower right corner shows **P:00**, Press “**OK**”.
- Press “^” to scroll through the menu. The lower right corner shows **AF**. Press “**OK**”.
- Press “**Back**” to exit the test mode.

NOTE: T1, T2, T2b, T3, T4 are sub-menus for thermistors. DO NOT select to set the external static pressure.

NOTE: Before commissioning, check the power connection of the machine, turn on the power, and keep the machine not working.

NOTE: If there is no change after airflow adjustment, perform the setting again.

NOTE: Setting Static Pressure or Automatic Airflow need to use the Wired Remote Controller.

NOTE: Low static pressure series 06K,09K,12K,18K models, SP options can only be “1~4”.

FAN PERFORMANCES AT VARYING STATIC PRESSURES

The factory default setting is SP1. Airflows and fan curves applicable starting on production of Week 28 Year 2020 (Serial Number 2820V10001). For previous serial numbers refer to previous revision of this document.

Low Static

Table 18 — 06K/09K

		IN.W.G CFM	0	0.04	0.08	0.1	0.12	0.16	0.2	0.24	0.28	0.3	0.32	0.36	0.4	
			06K/09K	SP4	Turbo										446	421
H												404	373	313	260	
M													358	324	265	214
L													315	278	208	141
SP3	Turbo									445	404	361	335			
	H									381	339	293	270			
	M									333	285	242	218			
	L									271	220	170	148			
SP2	Turbo					430	412	374	340							
	H					374	353	311	271							
	M					318	297	258	213							
	L					267	242	204	153							
SP1	Turbo	402		365	326	307										
	H	365		326	282	262										
	M	330		286	241	214										
	L	286		238	185	161										

Table 19 — 12K

		IN.W.G CFM	0	0.04	0.08	0.1	0.12	0.16	0.2	0.24	0.28	0.3	0.32	0.36	0.4	
			12K	SP4	Turbo										521	489
H												466	434	376	318	
M													418	378	312	261
L													373	325	249	183
SP3	Turbo									544	489	431	397			
	H									489	431	371	336			
	M									450	388	314	268			
	L									398	331	245	190			
SP2	Turbo					527	497	447	393							
	H					460	433	380	330							
	M					412	378	324	271							
	L					358	330	262	181							
SP1	Turbo	490		461	428	408										
	H	426		384	343	318										
	M	374		327	285	260										
	L	320		260	202	173										

Low Static (CONT)

Table 20 — 18K

18K	CFM	IN.W.G	0	0.04	0.08	0.1	0.12	0.16	0.2	0.24	0.28	0.3	0.32	0.36	0.4
			SP4	Turbo											686
H												636	618	586	555
M												580	565	532	498
L												520	496	462	421
SP3	Turbo								678	650	620	612			
	H								627	591	563	553			
	M								571	537	509	500			
	L								513	480	450	438			
SP2	Turbo				724	690	642	603							
	H				662	631	584	556							
	M				611	581	536	504							
	L				554	525	484	452							
SP1	Turbo	692	647	603	582										
	H	613	566	523	494										
	M	550	514	465	443										
	L	496	459	418	397										

<300 CFM | >450 CFM - Airflow below 300 CFM or above 450 cfm/ton

High Static

Table 21 — 09K

	In.w.g	CFM																												
		0	0.04	0.08	0.1	0.12	0.16	0.2	0.24	0.28	0.3	0.32	0.36	0.4	0.44	0.48	0.5	0.52	0.56	0.6	0.64	0.68	0.7	0.72	0.76	0.8				
09K SP8	Turbo																									434	403	368	348	
	H																										384	360	331	316
	M																										334	305	274	254
	L																										270	225	178	147
SP7	Turbo																			460	415	370	346							
	H																			389	354	322	295							
	M																			325	298	271	244							
	L																			277	237	196	149							
SP6	Turbo																450	427	391	356										
	H																398	377	343	305										
	M																326	303	262	234										
	L																283	254	202	153										
SP5	Turbo												483	437	391	368														
	H												391	357	324	306														
	M												337	288	242	214														
	L												283	237	190	160														
SP4	Turbo									478	454	405	361																	
	H									406	385	348	303																	
	M									361	342	305	256																	
	L									300	278	237	174																	
SP3	Turbo							472	418	361	338																			
	H							404	354	308	287																			
	M							362	316	273	247																			
	L							300	266	220	172																			
SP2	Turbo				468	448	409	354																						
	H				400	381	343	305																						
	M				348	330	297	260																						
	L				292	271	234	200																						
SP1	Turbo	441	406	370	353																									
	H	403	366	327	306																									
	M	377	330	283	265																									
	L	338	290	234	206																									

High Static (CONT)

Table 22 — 12K

	IN.W.G	CFM																												
		0	0.04	0.08	0.1	0.12	0.16	0.2	0.24	0.28	0.3	0.32	0.36	0.4	0.44	0.48	0.5	0.52	0.56	0.6	0.64	0.68	0.7	0.72	0.76	0.8				
12K SP8	Turbo																									500	477	445	414	
	H																										459	432	401	374
	M																										407	380	353	334
	L																										353	334	290	242
SP7	Turbo																				624	541	461	426						
	H																				560	490	418	370						
	M																				500	436	366	317						
	L																				421	356	285	243						
SP6	Turbo																607	574	501	447										
	H																484	465	427	383										
	M																401	380	350	327										
	L																332	307	271	242										
SP5	Turbo													603	543	483	456													
	H													549	485	431	394													
	M													484	420	356	322													
	L													407	347	284	248													
SP4	Turbo										615	584	516	456																
	H										556	521	456	387																
	M										507	472	393	321																
	L										454	418	337	278																
SP3	Turbo							647	562	474	427																			
	H							559	483	415	380																			
	M							504	426	347	303																			
	L							438	376	297	247																			
SP2	Turbo				566	541	489	426																						
	H				531	509	441	371																						
	M				490	464	396	307																						
	L				438	407	339	250																						
SP1	Turbo	489	457	428	411																									
	H	441	402	360	338																									
	M	408	356	307	284																									
	L	372	312	248	230																									

High Static (CONT)

Table 23 — 18K

	In.w.g	CFM																									
		0	0.04	0.08	0.1	0.12	0.16	0.2	0.24	0.28	0.3	0.32	0.36	0.4	0.44	0.48	0.5	0.52	0.56	0.6	0.64	0.68	0.7	0.72	0.76	0.8	
18K	SP8	Turbo																						910	863	782	700
		H																						849	808	722	636
		M																						763	723	614	486
		L																						707	657	543	425
SP7	Turbo																			918	828	725	677				
	H																			823	739	653	610				
	M																			769	684	590	536				
	L																			669	609	531	463				
SP6	Turbo																918	881	782	683							
	H																825	793	707	609							
	M																733	700	621	543							
	L																646	614	545	445							
SP5	Turbo												918	831	735	692											
	H												876	768	655	606											
	M												813	707	602	534											
	L												726	634	546	465											
SP4	Turbo									926	892	810	735														
	H									877	829	723	619														
	M									795	744	637	519														
	L									696	644	538	424														
SP3	Turbo							890	842	776	742																
	H							838	758	677	639																
	M							776	680	586	535																
	L							672	578	491	438																
SP2	Turbo			856	830	783	718																				
	H			805	778	725	641																				
	M			738	703	625	534																				
	L			434	414	368	315																				
SP1	Turbo	820	776	737	707																						
	H	711	676	616	577																						
	M	645	600	537	488																						
	L	574	524	465	426																						

High Static (CONT)

Table 24 — 24K

	In.w.g	CFM																										
		0	0.04	0.08	0.1	0.12	0.16	0.2	0.24	0.28	0.3	0.32	0.36	0.4	0.44	0.48	0.5	0.52	0.56	0.6	0.64	0.68	0.7	0.72	0.76	0.8		
24K SP8	Turbo																							1008	975	904	855	
	H																							866	831	780	716	
	M																							773	735	673	606	
	L																							680	639	549	486	
SP7	Turbo																			1024	968	902	877					
	H																			889	836	786	759					
	M																			786	731	678	647					
	L																			657	609	531	463					
SP6	Turbo																1008	972	908	845								
	H																890	858	790	735								
	M																780	743	686	622								
	L																682	661	569	510								
SP5	Turbo												1022	952	882	855												
	H												935	861	784	729												
	M												840	758	678	634												
	L												749	650	556	519												
SP4	Turbo									1008	965	904	839															
	H									916	886	829	753															
	M									846	808	724	624															
	L									766	720	637	522															
SP3	Turbo							1001	909	846	810																	
	H							898	832	757	731																	
	M							843	773	691	652																	
	L							719	660	589	527																	
SP2	Turbo				996	951	883	832																				
	H				893	863	801	746																				
	M				801	776	713	644																				
	L				697	672	593	496																				
SP1	Turbo	998	929	863	827																							
	H	891	811	742	715																							
	M	762	692	614	588																							
	L	633	572	497	461																							

High Static (CONT)

Table 25 — 36K

36K	In.w.g	CFM																												
		0	0.06	0.12	0.148	0.16	0.2	0.22	0.24	0.28	0.3	0.32	0.36	0.4	0.44	0.48	0.5	0.52	0.56	0.6	0.64	0.68	0.7	0.72	0.76	0.8				
SP8	Turbo																									1699	1621	1493	1370	
	H																										1595	1501	1374	1254
	M																										1477	1383	1257	1137
	L																										1342	1248	1121	1004
SP7	Turbo																				1642	1524	1410	1333						
	H																				1503	1380	1248	1195						
	M																				1354	1225	1112	1030						
	L																				1237	1092	926	794						
SP6	Turbo																1570	1506	1418	1343										
	H																1442	1388	1298	1226										
	M																1295	1236	1151	1074										
	L																1107	1031	936	854										
SP5	Turbo													1629	1514	1387	1327													
	H													1502	1398	1271	1189													
	M													1413	1283	1160	1071													
	L													1277	1165	1018	921													
SP4	Turbo																1548	1480	1392	1301										
	H																1413	1366	1268	1185										
	M																1260	1201	1112	1031										
	L																1092	1030	924	856										
SP3	Turbo																													
	H																													
	M																													
	L																													
SP2	Turbo																													
	H																													
	M																													
	L																													
SP1	Turbo	1567	1464	1349	1268																									
	H	1304	1192	1046	970																									
	M	1062	930	798	732																									
	L	898	727	584	515																									

High Static (CONT)

Table 26 — 48K

	In.w.g	CFM																							
		0	0.06	0.12	0.18	0.2	0.24	0.28	0.3	0.32	0.36	0.4	0.44	0.48	0.5	0.52	0.56	0.6	0.64	0.68	0.7	0.72	0.76	0.8	
48K SP8	Turbo																				2279	2161	1972	1779	
	H																				2020	1948	1793	1629	
	M																				1866	1751	1595	1423	
	L																				1624	1569	1401	1184	
SP7	Turbo																	2226	2102	1913	1722				
	H																	2020	1901	1746	1547				
	M																	1836	1716	1566	1397				
	L																	1583	1474	1248	1057				
SP6	Turbo														2126	2061	1919	1745							
	H														1932	1866	1746	1590							
	M														1713	1669	1566	1423							
	L														1507	1474	1366	1230							
SP5	Turbo										2067	1978	1825	1710											
	H										1891	1807	1669	1567											
	M										1705	1651	1536	1423											
	L										1507	1457	1336	1230											
SP4	Turbo								2032	1978	1856	1728													
	H								1861	1807	1699	1557													
	M								1705	1651	1554	1401													
	L								1507	1439	1324	1195													
SP3	Turbo					3332	3120	2934	2828																
	H					3050	2820	2652	2521																
	M					2700	2462	2300	2170																
	L					2416	2202	2040	1951																
SP2	Turbo	3410	3275	3110	2925	2862																			
	H	3120	2985	2840	2645	2547																			
	M	2776	2675	2510	2350	2278																			
	L	2482	2355	2185	2020	1960																			
SP1	Turbo	1960	1881	1783	1675	1637																			
	H	2820	2685	2520	2335	2272																			
	M	2562	2425	2260	2075	2010																			
	L	2272	2135	1970	1780	1720																			

High Static (CONT)

Table 27 — 60K

	In.w.g	CFM																								
		0	0.04	0.08	0.12	0.16	0.2	0.24	0.28	0.3	0.32	0.36	0.4	0.44	0.48	0.5	0.52	0.56	0.6	0.64	0.68	0.7	0.72	0.76	0.8	
60K SP8	Turbo																						2484	2372	2107	1777
	H																						2203	2101	1848	1580
	M																						1985	1868	1609	1331
	L																						1784	1682	1420	1134
60K SP7	Turbo																		2472	2295	2107	1998				
	H																		2203	2026	1832	1699				
	M																		2038	1850	1567	1325				
	L																		1848	1599	1264	1024				
60K SP6	Turbo															2472	2390	2239	2069							
	H															2203	2134	1995	1858							
	M															2008	1953	1775	1519							
	L															1848	1710	1447	1279							
60K SP5	Turbo											2464	2331	2205	2129											
	H											2284	2154	2035	1958											
	M											2069	1952	1835	1739											
	L											1894	1743	1546	1325											
60K SP4	Turbo									2451	2390	2295	2182													
	H									2244	2191	2060	1897													
	M									2037	1947	1790	1650													
	L									1735	1655	1471	1203													
60K SP3	Turbo						2353	2267	2144	2067																
	H						2149	2042	1907	1809																
	M						1945	1798	1660	1573																
	L						1696	1543	1360	1188																
60K SP2	Turbo	2536	2447	2329	2225	2129	2012																			
	H	2370	2260	2147	2036	1926	1802																			
	M	2171	2060	1942	1825	1686	1533																			
	L	2014	1891	1773	1630	1480	1324																			
60K SP1	Turbo	2473	2367	2277	2178	2070	1961																			
	H	2167	2058	1949	1822	1709	1530																			
	M	2035	1912	1793	1677	1516	1366																			
	L	1899	1772	1648	1507	1338	1138																			

<300 CFM >450 CFM - Airflow below 300 CFM or above 450 cfm/ton

E. WIRE CONNECTIONS

WIRING PRECAUTIONS



WARNING

Before performing any electrical work, read these warnings.

Before any electrical or wiring work, turn off the main power to the system.

All wiring must comply with local and national electrical codes, regulations and must be installed by a licensed electrician.

All electrical connections must be made according to the Electrical Connection Diagram located on the panels of the indoor and outdoor units.

If there is a serious safety issue with the power supply, stop work immediately. Explain your reasoning to the client, and refuse to install the unit until the safety issue is properly resolved.

Power voltage should be within 90-110% of rated voltage. Insufficient power supply can cause malfunction, electrical shock, or fire. Installation of an external surge suppressor at the outdoor disconnect is recommended.

If connecting power to fixed wiring, a switch or circuit breaker that disconnects all poles and has a contact separation of at least 1/8in (3mm) must be incorporated in the fixed wiring. The qualified technician must use an approved circuit breaker or switch.

Only connect the unit to an individual branch circuit. Do not connect another appliance to that outlet. Make sure to properly ground the air conditioner.

Every wire must be firmly connected. Loose wiring can cause the terminal to overheat, resulting in product malfunction and possible fire.

Do not let wires touch or rest against refrigerant tubing, the compressor, or any moving parts within the unit.

If the unit has an auxiliary electric heater, it must be installed at least 40 in (1 m) away from any combustible materials.

To avoid getting an electric shock, never touch the electrical components soon after the power supply has been turned off. After turning off the power, always wait 10 minutes or more before you touch the electrical components.

Make sure that you do not cross your electrical wiring with your signal wiring. This may cause distortion, interference or possibly damage to circuit boards.

No other equipment should be connected to the same power circuit.

Connect the outdoor wires before connecting the indoor wires.

CONNECTION DIAGRAMS

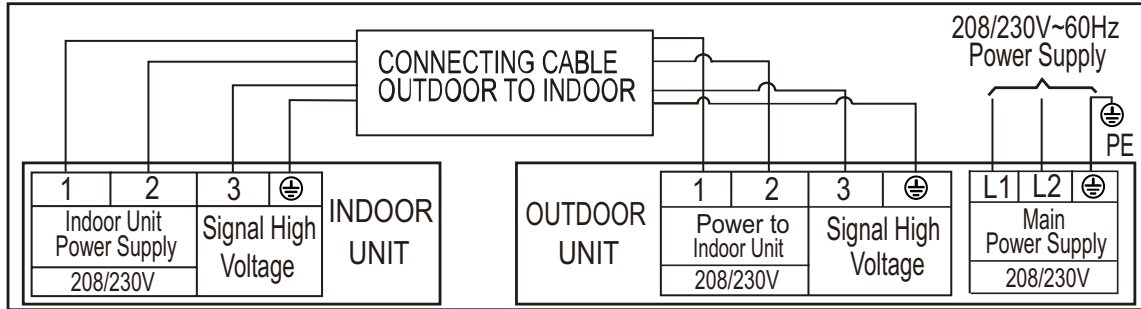

Fig. 64 — Sizes 06K, 09K, 12K, 18K (Low Static)

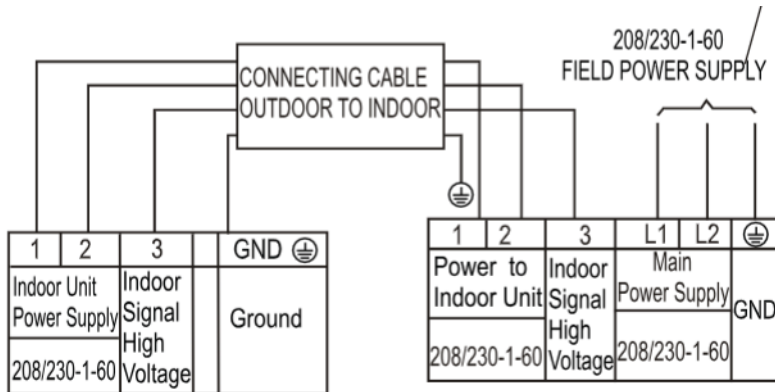

Fig. 65 — Sizes 09K, 12K, 18K, 24K (High Static)

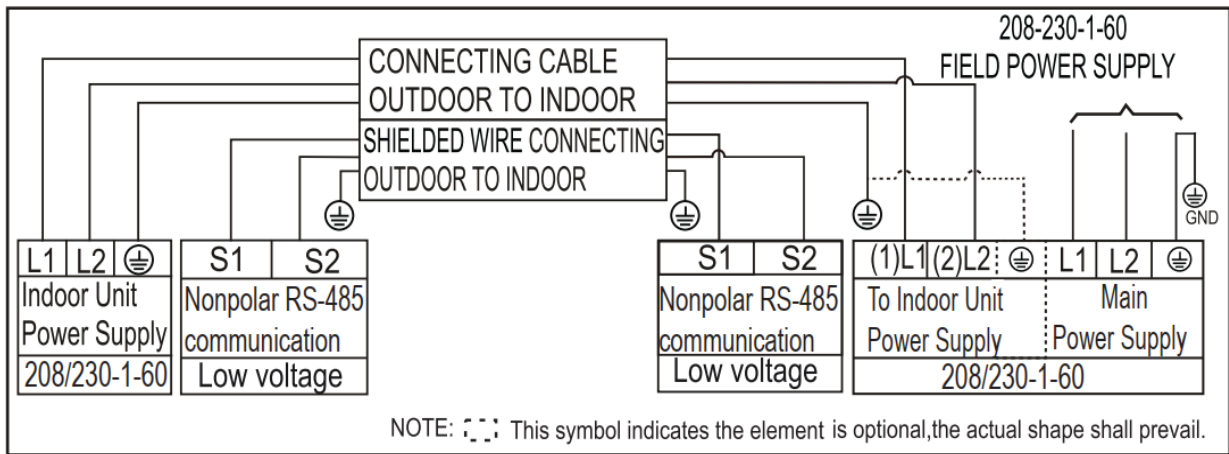

Fig. 66 —Size 36K (High Static)

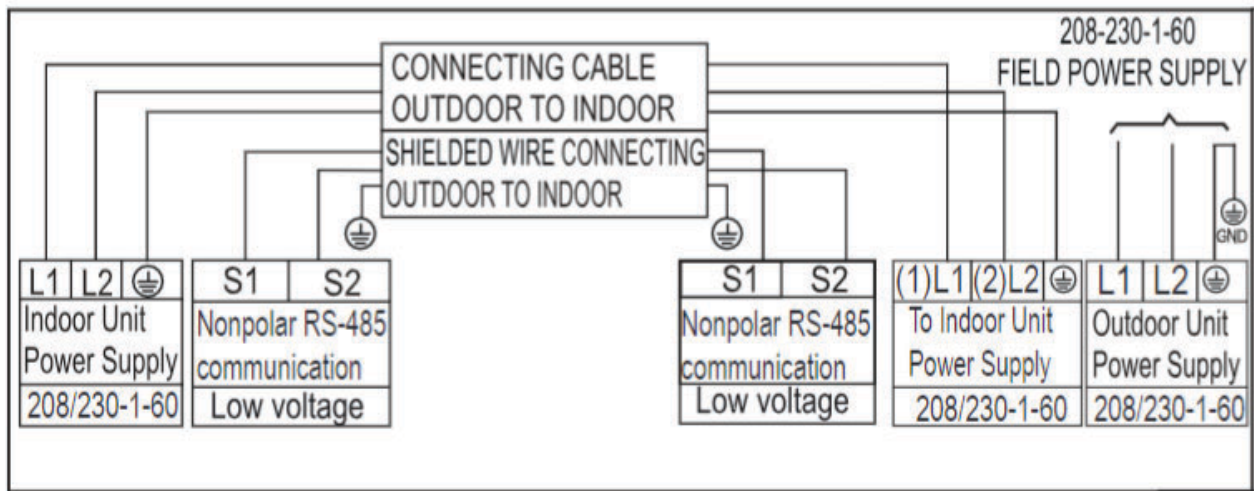

Fig. 67 —Sizes 48K and 58K (High Static)

WIRING DIAGRAMS

NOTE: Refer to the diagram label on the unit.

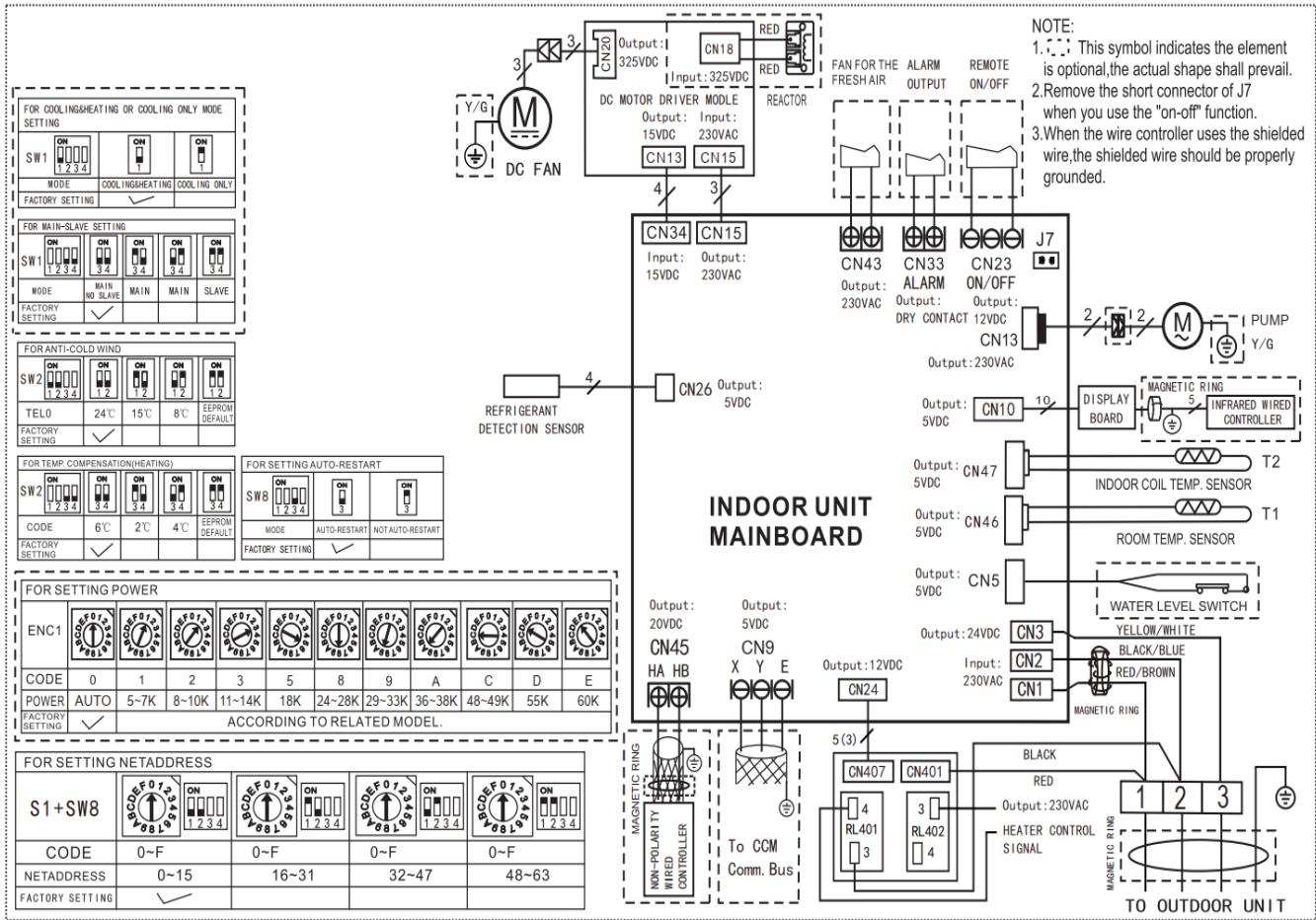

Fig. 68 —Size 06K

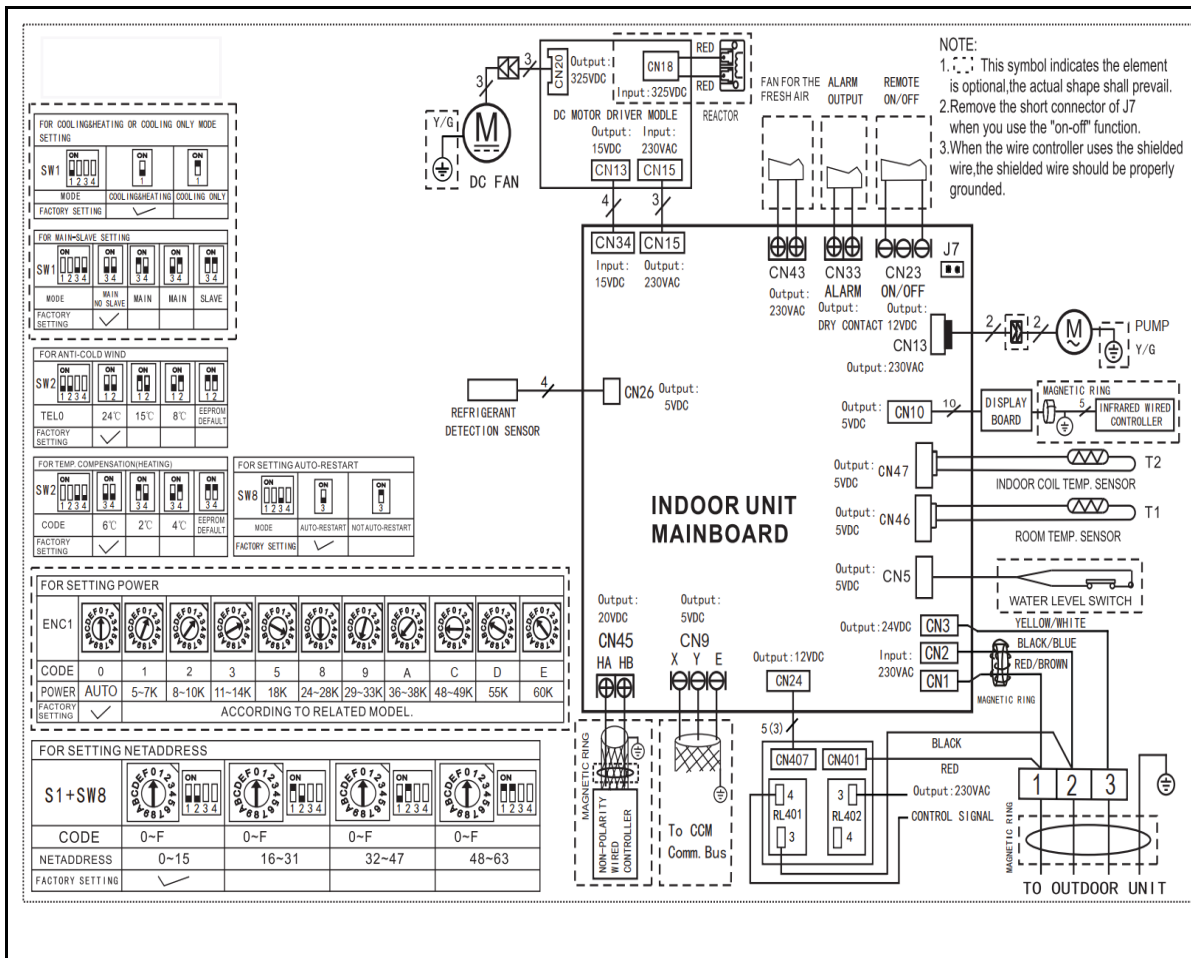

Fig. 69 — Sizes 09K, 12K, 18K, 24K

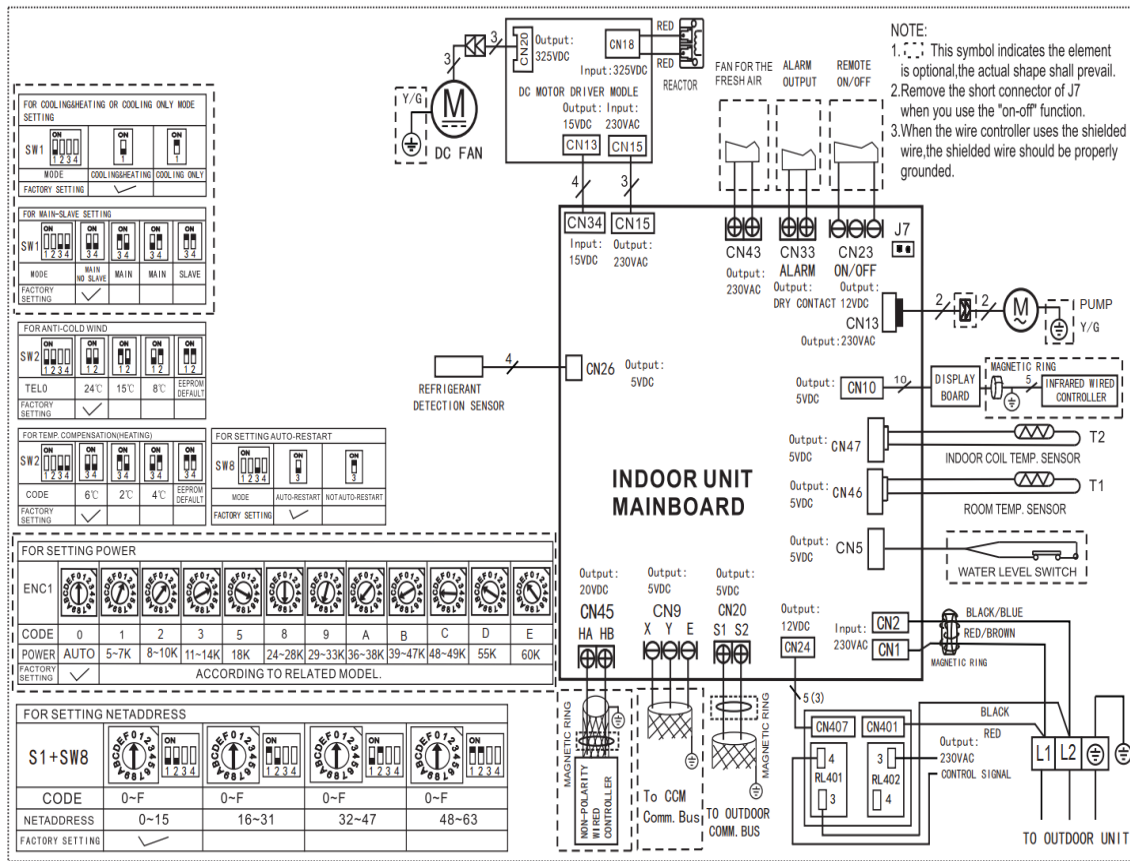

Fig. 70 — Sizes 36K - 60K

CAPACITY SETTING

ECN1 Dip Switch Instruction for Capacity Change

ECN1 dip switch is used for capacity change

When matching with single zone condensers, the indoor unit will automatically adjust to 9,000 BTU/H or 12,000 BTU/ according to condensers capacity.

When matching with multi-zone condensers, the ECN1 setting needs to be changed. Change the capacity of the indoor unit to 9,000 BTU/H by adjusting the dip switch ECN1 from "0" to "2". Change the capacity of indoor unit to 12,000 BTU/H by adjusting the dip switch ECN1 from "0" to "3".

Power needs to be turned OFF BEFORE DIP SWITCH adjustment.



(Default setting "0")

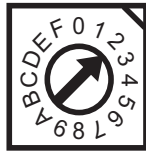

(Change Dip switch to "2" for 9,000BTU/H)

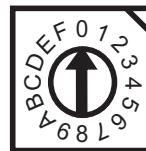

(Default setting "0")

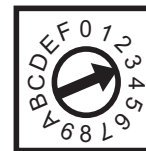

(Change Dip switch to "3" for 12,000BTU/H)

DIP SWITCH SETTINGS

Table 28 — Dip Switch Settings

NO.	DIAL CODE	FUNCTION	ON	OFF	1 ON&2 ON	1 ON&2 OFF	1 OFF&2 ON	1 OFF&2 OFF
1	SW1-1	COOLING and HEATING or COOLING Only setting	COOLING Only	[Default] COOLING and HEATING	N/A	N/A	N/A	N/A
2	SW2-1&SW2-2	Indoor fan stop temperature (TELO) for normal anti-cold air function in HEATING mode	N/A	N/A	According to EEROM setting	15°C	8°C	[Default]24°C
3	SW2-3&SW2-4	Heating temperature compensation	N/A	N/A	According to EEROM setting	4°C	2°C	[Default]6°C
4	SW8-1&SW8-2+ Rotary Switch S1	Central control address selection	N/A	N/A	48+S1	16+S1	32+S1	S1
5	SW8-3	Auto-restart setting	Will not maintain previous setting	[Default] Run at previous setting	N/A	N/A	N/A	N/A
6	Rotary Switch ENC1	Capacity selection	[Default] Auto detection: ENC1=0; 6K: ENC1=1; 9K:ENC1=2; 12K: ENC1=3; 18K:ENC1=5; 24K: ENC1=8; 36K: ENC1=A; 48K: ENC1=C; 60K: ENC1=E					

Note on Circuit Breaker

When the maximum current of the air conditioner is more than 16A, a circuit breaker or leakage protection switch with protective device shall be used (purchased separately). When the maximum current of the air conditioner is less than 16A, the power cord of air conditioner shall be equipped with plug (purchased separately). In North America, the appliance should be wired according to NEC and CEC requirements.

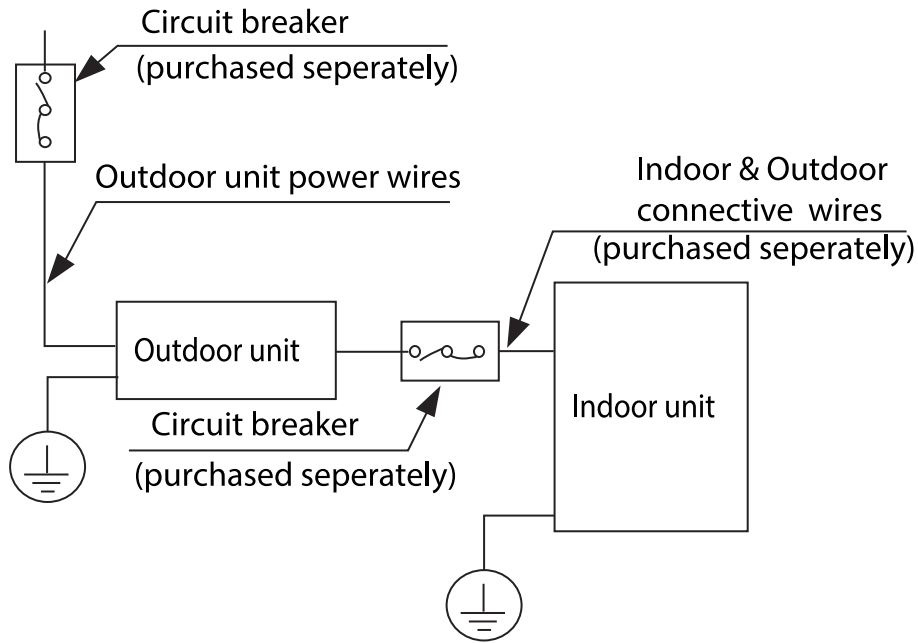

Fig. 71 —Circuit Breaker Use

NOTE: The graphs are for explanation purposes only. Your unit may differ slightly. The actual shape shall prevail.

INDOOR UNIT WIRING

1. Prepare the cable for connection.
 - a. Using wire strippers, strip the rubber jacket from both ends of the signal cable to reveal about 5.9 in (15 cm) of the wire.
 - b. Strip the insulation from the ends of the wires.
 - c. Using a wire crimper, crimp the u-lugs to the ends of the wires.
2. Remove the cover of the electric control box on your indoor unit.
3. Connect the u-lugs to the terminals.
4. Match the wire colors/labels with the labels on the terminal block. Firmly screw the u-lug of each wire to its corresponding terminal. Refer to the Serial Number and Wiring Diagram located on the cover of the electric control box.

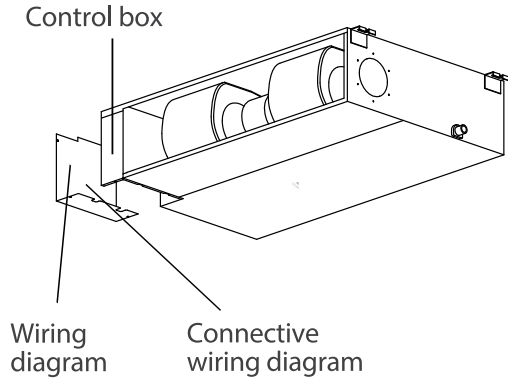

Fig. 72 —Indoor Unit Control Box and Wiring Diagram

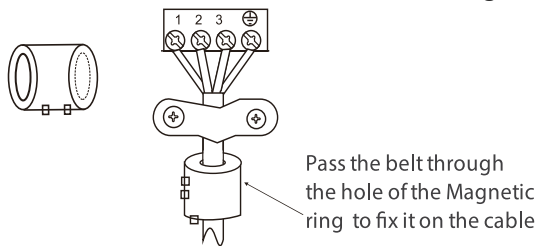

Fig. 73 —Magnetic Ring (if supplied and packed with accessories)

CAUTION

While connecting the wires, please strictly follow the wiring diagram.
 The refrigerant circuit can become very hot.
 Keep the interconnection cable away from the copper tube.

5. Clamp down the cable with the cable clamp. The cable must not be loose or pull on the u-lugs.
6. The display box needs to be installed in the electric control box, the display box needs to be installed inside the electric control, stuck on the electric control box sheet metal clips.

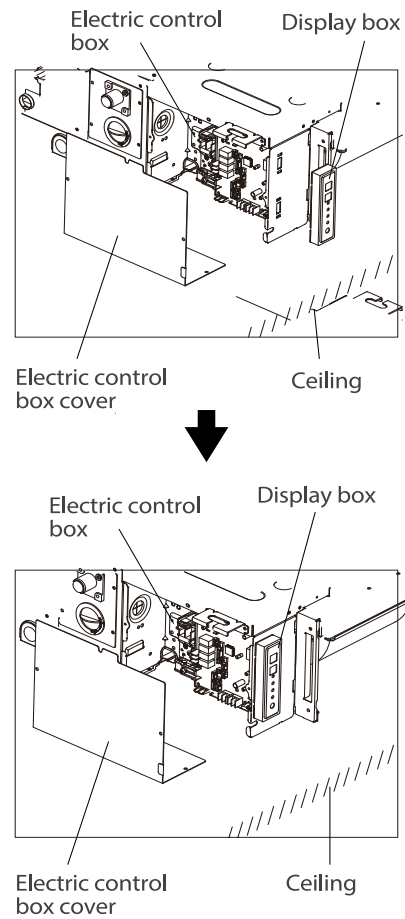

Fig. 74 —Display Box Installation

- The display box needs to be installed to the outside of the indoor unit.
 - The wiring of the wired controller needs to be completed inside the electric control box.
 - The indoor unit needs to be ceiling mounted.
7. Reattach the electric box cover.

TEST RUN



CAUTION

Failure to perform the test run may result in unit damage, property damage, or personal injury.

Before Test Run

A test run must be performed after the entire system has been completely installed. Confirm the following points before performing the test:

- a. Indoor and outdoor units are properly installed.
- b. Piping and wiring are properly connected.
- c. No obstacles near the inlet and outlet of the unit that might cause poor performance or product malfunction.
- d. Refrigeration system does not leak.
- e. Drainage system is unimpeded and draining to a safe location.
- f. Heating insulation is properly installed.
- g. Grounding wires are properly connected.
- h. Length of the piping and additional refrigerant capacity have been recorded.
- i. Power voltage is the correct voltage for the air conditioner

Test Run Instructions

1. Open both the liquid and gas stop valves.
2. Turn on the main power switch and allow the unit to warm up.
3. Set the air conditioner to **COOL** mode.
4. For the Indoor Unit:
 - a. Ensure the remote control and its buttons work properly.
 - b. Ensure the louvers move properly and can be changed using the remote control.
 - c. Double check to see if the room temperature is being registered correctly.
 - d. Ensure the indicators on the remote control and the display panel on the indoor unit work properly.
 - e. Ensure the manual buttons on the indoor unit works properly.
 - f. Ensure the drainage system is unimpeded and draining smoothly.
 - g. Ensure there is no vibration or abnormal noise during operation.
5. For the Outdoor Unit:
 - a. Check to see if the refrigeration system is leaking.
 - b. Ensure there is no vibration or abnormal noise during operation.
 - c. Ensure the wind, noise, and water generated by the unit do not disturb your neighbors or pose a safety hazard.
6. Drainage Test
 - a. Ensure the drainpipe flows smoothly. New buildings should perform this test before finishing the ceiling.
 - b. Remove the test cover. Add .5 gallon of water to the tank through the attached tube.
 - c. Turn on the main power switch and run the air conditioner in **COOL** mode. Listen to the sound of the drain pump to see if it makes any unusual noises.
 - d. Ensure the water is discharged. It may take up to one minute before the unit begins to drain depending on the drainpipe.
 - e. Ensure there are no leaks in any of the piping.
 - f. Stop the air conditioner. Turn off the main power switch and reinstall the test cover.

NOTE: If the unit malfunctions or does not operate according to your expectations, please refer to the Troubleshooting section of the Owner's Manual before calling customer service.

TROUBLESHOOTING

Table 29 — Error Codes

Display	Malfunction and Protection Indication
EC07	ODU Fan Speed Out of Control
EC51	ODU EEPROM Parameter Error
EC52	ODU Coil Temperature Sensor(T3) error
EC53	ODU Ambient Temperature Sensor (T4) Error
EC54	COMP. Discharge Temperature Sensor (TP) Error
EC5b	IDU Coil Temperature Sensor (T2B) Error
ECC1	Other IDU Refrigerant Sensor Detects Leakage (Multi-zone)*
EH00	IDU EEPROM Malfunction
EH03	IDU Fan Speed Out of Control
EH0A	IDU EEPROM Parameter Error
EH0E	Water Level Alarm Malfunction
EH12	Main Unit or Secondary Units Malfunction
EH3A	External Fan DC bus voltage is too low protection
EH3b	External Fan DC bus voltage is too high fault
EH60	IDU Room Temperature (T1) Error
EH61	IDU Coil Temperature Sensor (T2) Error
EHba	Communication Error between the indoor unit and the external fan module
EHC1	Refrigerant Sensor Detects Leakage
EHC2	Refrigerant Sensor is out of range and a leak is detected
EHC3	Refrigerant Sensor is out of range*
EL01	IDU and ODU Communication Error
EL0C	System lacks refrigerant
EL11	Communication Malfunction between the main and secondary units
FH07	IDU lift panel communication failure/IDU opening and closing failure
FHCC	Refrigerant Sensor Error*
PC00	ODU IPM Module Protection
PC01	ODU Voltage Protection
PC02	Compressor To (or IPM Module Protection
PC03	Pressure Protection (Low or High Pressure)
PC04	Inverter Compressor Drive Error
PC0L	Low Ambient Temperature Protection
NOTE: The digital tube will display FC in the FORCED COOLING mode. FC is NOT an error code. *Applicable to the units with refrigerant sensors only.	

Table 30 — Refrigerant Leak Detection Error Codes

EHC1	Refrigerant Sensor detects a leak
EHC2	Working condition of the refrigerant sensor is out of range and a leak is detected

If you receive one of the codes in Table 30, call a technician as soon as possible. No need to panic, the unit goes into TURBO mode until the error code is cleared. There is a “beep” noise coming from the indoor unit, which is normal in this case.

For additional diagnostic information, refer to the Service Manual.

DUCTLESS START - UP CHECKLIST - Single Zone

Installation Data

Site Address: _____
 City: _____ State: _____ Zip Code: _____
 Installing Contractor: _____ Contractor Contact #: () _____ - _____
 Job Name: _____ Start-up Date: _____
 Distributor: _____

System Details

UNITS	MODEL NO.	SERIAL NO.	CONTROLLER
OUTDOOR UNIT			
INDOOR UNIT A			

Are the outdoor unit and indoor unit compatible? YES: _____
 NO: _____

Wiring Electrical

Wire Size and Type Used? AWG: _____ TYPE: _____

Are there any breaks, splices, wire nuts or butt connectors between the outdoor unit and the indoor unit? YES: _____ NO: _____

Was the wiring from the outdoor unit port to the correct indoor unit verified? YES: _____ NO: _____

REMARKS: _____

Voltage Check

Wiring: Single Zone

Outdoor Unit Disconnect	1(L1):GND		Outdoor Unit Terminal Block	1(L1):GND		NOTES: _____ _____ _____
	2(L2):GND			2(L2):GND		
	1(L1):L2(2)			1(L1):2(L2)		
Indoor Unit Voltage Check @ Outdoor Unit	1(L1):GND		Indoor Unit Voltage Check @ Indoor Unit	1(L1):GND		NOTES: _____ _____ _____
	2(L2):GND			2(L2):GND		
	1(L1):2(L2)			1(L1):2(L2)		
	2(L2):3(S)			2(L2):3(S)		

Outdoor Unit Disconnect	1(L1):GND		Outdoor Unit Terminal Block	1(L1):GND		NOTES: _____ _____ _____
	2(L2):GND			2(L2):GND		
	1(L1):L2(2)			1(L1):2(L2)		
Indoor Unit Voltage Check @ Outdoor Unit	1(L1):GND		Indoor Unit Voltage Check @ Indoor Unit	1(L1):GND		NOTES: _____ _____ _____
	2(L2):GND			2(L2):GND		
	1(L1):2(L2)			1(L1):2(L2)		
	2(L2):3(S)			2(L2):3(S)		

Ductless Start-Up Checklist (CONT)

Piping

Leak Check:

System held 500 psig (max. 550psi) for a minimum of 30 minutes using dry nitrogen. YES: _____ NO: _____

Evacuation Method:

- Was the Triple Evacuation Method used as outlined in the installation manual? YES: _____ NO: _____
- Was the Deep Vacuum Method used as outlined in the installation manual? YES: _____ NO: _____
- Did the System Hold 500 microns for 1 hour? YES: _____ NO: _____
- Does the line set match the diameter of the evaporator connections? YES: _____ NO: _____
- For Conventional Fan Coils, does the line set match the outdoor unit size? YES: _____ NO: _____

Single Zone Piping:

Has the liquid pipe length been measured and the additional charge calculated? Size: _____ Length: _____ Charge: _____

NOTES:

NOTE: Final Charge Amount must be recorded!

PORT	LIQUID SIZE	SUCTION SIZE	LENGTH	CHARGE	NOTES: _____
A					

Performance Check

<p>For 1:1 Single Zone Systems: Adjust the set-point to create an operational call for the desired testing operation. Allow the system to run for a minimum of 10 min. and record the following details:</p> <p>(Operational data recorded on applicable heads with the wireless remote controller's Point Check function)</p>										
UNIT	SET-POINT	MODE	T1	T2	T3	T4	Tb	Tp	Th	LA/Lr
A										

- NOTE:**
- T1 - Ambient Space Temperature Sensor
 - T2 - IDU Coil Temperature Sensor
 - T3 - Outdoor Coil Temperature Sensor
 - T4 - Outdoor Ambient Temperature
 - Tb - Suction Line Temperature @PMV
 - Tp - Discharge Temperature Sensor
 - Th - IPM Board Temperature
 - LA/Lr - PMV Temperature

Error Codes

Were there any error codes present at start-up?
 YES: _____ NO: _____

Indoor Unit Error Code:		Notes:
Outdoor Unit Error Code:		
Wall Controller:		
24V Interface:		

Comments:
